

# AM26C31C, AM26C31I, AM26C31M QUADRUPLE DIFFERENTIAL LINE DRIVERS

SLLS103G – DECEMBER 1990 – REVISED SEPTEMBER 1998

- Meet or Exceed the Requirements of TIA/EIA-422-B and ITU Recommendation V.11
- Low Power,  $I_{CC} = 100 \mu A$  Typ
- Operate From a Single 5-V Supply
- High Speed,  $t_{PLH} = t_{PHL} = 7 \text{ ns}$  Typ
- Low Pulse Distortion,  $t_{sk(p)} = 0.5 \text{ ns}$  Typ
- High Output Impedance in Power-Off Conditions
- Improved Replacement for AM26LS31

## description

The AM26C31C, AM26C31I, and AM26C31M are four complementary-output line drivers designed to meet the requirements of TIA/EIA-422-B and ITU (formerly CCITT). The 3-state outputs have high-current capability for driving balanced lines, such as twisted-pair or parallel-wire transmission lines, and they provide the high-impedance state in the power-off condition. The enable function is common to all four drivers and offers the choice of an active-high or active-low enable input. BiCMOS circuitry reduces power consumption without sacrificing speed.

The AM26C31C is characterized for operation from 0°C to 70°C, the AM26C31I is characterized for operation from -40°C to 85°C, and the AM26C31M is characterized for operation from -55°C to 125°C.

AM26C31C, AM26C31I . . . D, DB†, OR N PACKAGE  
AM26C31M . . . J OR W PACKAGE  
(TOP VIEW)

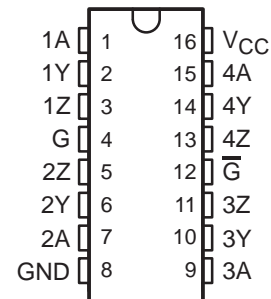

† The DB package is only available left-ended taped (order AM26C31IDBLE or AM26C31CDBLE).

AM26C31M . . . FK PACKAGE  
(TOP VIEW)

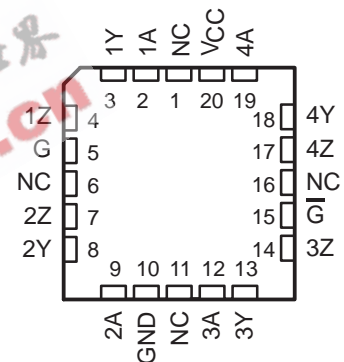

NC – No internal connection

FUNCTION TABLE  
(each driver)

INPUT A	ENABLES		OUTPUTS	
	G	$\bar{G}$	Y	Z
H	H	X	H	L
L	H	X	L	H
H	X	L	H	L
L	X	L	L	H
X	L	H	Z	Z

H = high level, L = low level, X = irrelevant,  
Z = high impedance (off)



Please be aware that an important notice concerning availability, standard warranty, and use in critical applications of Texas Instruments semiconductor products and disclaimers thereto appears at the end of this data sheet.

PRODUCTION DATA information is current as of publication date. Products conform to specifications per the terms of Texas Instruments standard warranty. Production processing does not necessarily include testing of all parameters.

 **TEXAS  
INSTRUMENTS**

POST OFFICE BOX 655303 • DALLAS, TEXAS 75265

Copyright © 1998, Texas Instruments Incorporated

# AM26C31C, AM26C31I, AM26C31M QUADRUPLE DIFFERENTIAL LINE DRIVERS

SLLS103G – DECEMBER 1990 – REVISED SEPTEMBER 1998

## logic symbol†

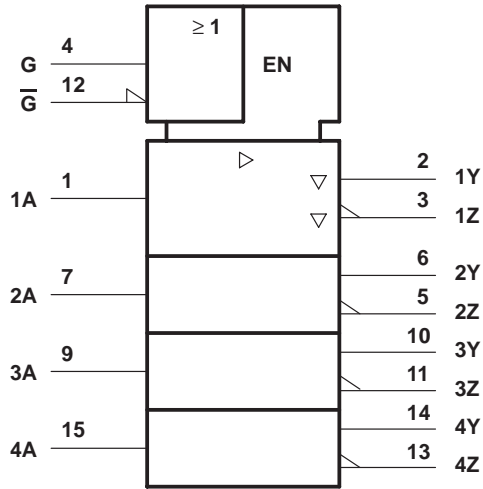

## logic diagram (positive logic)

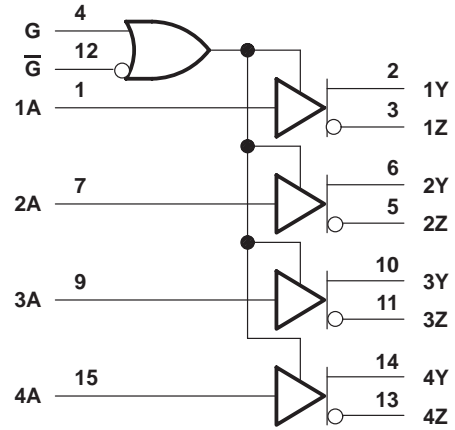

† This symbol is in accordance with ANSI/IEEE Std 91-1984 and IEC Publication 617-12. The terminal numbers shown are for the D, DB, J, N, and W packages.

## schematics of inputs and outputs

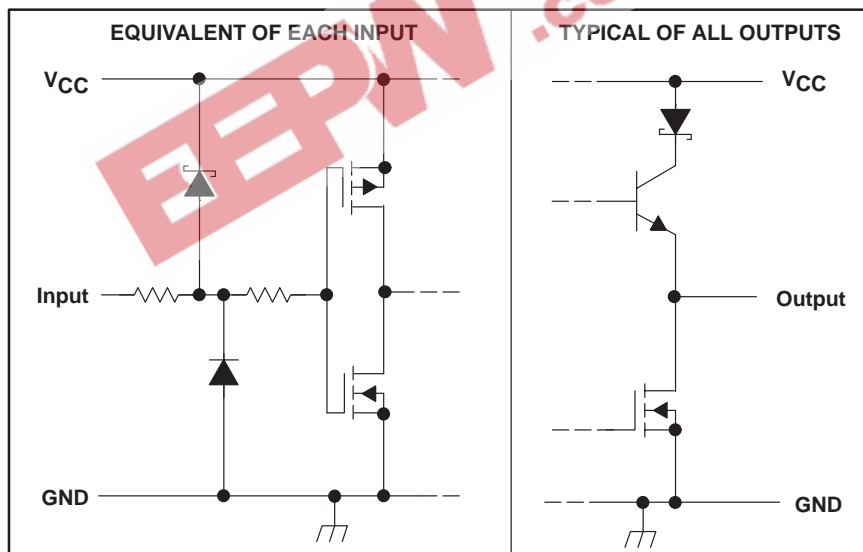

# AM26C31C, AM26C31I, AM26C31M QUADRUPLE DIFFERENTIAL LINE DRIVERS

SLLS103G – DECEMBER 1990 – REVISED SEPTEMBER 1998

## absolute maximum ratings over operating free-air temperature range (unless otherwise noted)†

Supply voltage range, $V_{CC}$ (see Note 1)	–0.5 V to 7 V
Input voltage range, $V_I$	–0.5 V to $V_{CC} + 0.5$ V
Differential input voltage range, $V_{ID}$	–14 V to 14 V
Output voltage range, $V_O$	–0.5 V to 7 V
Input or output clamp current, $I_{IK}$ or $I_{OK}$	±20 mA
Output current, $I_O$	±150 mA
$V_{CC}$ current	200 mA
GND current	–200 mA
Continuous total power dissipation	See Dissipation Rating Table
Storage temperature range, $T_{stg}$	–65°C to 150°C
Lead temperature 1,6 mm (1/16 inch) from case for 10 seconds	260°C

† Stresses beyond those listed under “absolute maximum ratings” may cause permanent damage to the device. These are stress ratings only, and functional operation of the device at these or any other conditions beyond those indicated under “recommended operating conditions” is not implied. Exposure to absolute-maximum-rated conditions for extended periods may affect device reliability.

NOTE 1: All voltage values, except differential output voltage ( $V_{OD}$ ), are with respect to the network ground terminal.

**DISSIPATION RATING TABLE**

PACKAGE	$T_A \leq 25^\circ\text{C}$ POWER RATING	DERATING FACTOR ABOVE $T_A = 25^\circ\text{C}$	$T_A = 70^\circ\text{C}$ POWER RATING	$T_A = 85^\circ\text{C}$ POWER RATING	$T_A = 125^\circ\text{C}$ POWER RATING
D	950 mW	7.6 mW/°C	608 mW	494 mW	—
DB	781 mW	6.2 mW/°C	502 mW	409 mW	—
N	1150 mW	9.2 mW/°C	736 mW	598 mW	—
FK	1375 mW	11 mW/°C	—	—	275 mW
J	1375 mW	11 mW/°C	—	—	275 mW
W	1000 mW	8.0 mW/°C	—	—	200 mW

## recommended operating conditions

		MIN	NOM	MAX	UNIT
Supply voltage, $V_{CC}$		4.5	5	5.5	V
Differential input voltage, $V_{ID}$		±7			V
High-level input voltage, $V_{IH}$		2			V
Low-level input voltage, $V_{IL}$		0.8			V
High-level output current, $I_{OH}$		–20			mA
Low-level output current, $I_{OL}$		20			mA
Operating free-air temperature, $T_A$	AM26C31C	0		70	°C
	AM26C31I	–40		85	
	AM26C31M	–55		125	

# AM26C31C, AM26C31I, AM26C31M QUADRUPLE DIFFERENTIAL LINE DRIVERS

SLLS103G – DECEMBER 1990 – REVISED SEPTEMBER 1998

**electrical characteristics over recommended ranges of supply voltage and operating free-air temperature (unless otherwise noted)**

PARAMETER	TEST CONDITIONS	AM26C31C AM26C31I			UNIT
		MIN	TYP†	MAX	
V <sub>OH</sub> High-level output voltage	I <sub>O</sub> = -20 mA	2.4	3.4		V
V <sub>OL</sub> Low-level output voltage	I <sub>O</sub> = 20 mA		0.2	0.4	V
V <sub>OD</sub>   Differential output voltage magnitude	R <sub>L</sub> = 100 Ω, See Figure 1	2	3.1		V
Δ V <sub>OD</sub>   Change in magnitude of differential output voltage‡				±0.4	V
V <sub>OC</sub> Common-mode output voltage				3	V
Δ V <sub>OC</sub>   Change in magnitude of common-mode output voltage‡				±0.4	V
I <sub>I</sub> Input current	V <sub>I</sub> = V <sub>CC</sub> or GND			±1	μA
I <sub>O(off)</sub> Driver output current with power off	V <sub>CC</sub> = 0, V <sub>O</sub> = 6 V			100	μA
	V <sub>CC</sub> = 0, V <sub>O</sub> = -0.25 V			-100	
I <sub>OS</sub> Driver output short-circuit current	V <sub>O</sub> = 0	-30		-150	mA
I <sub>OZ</sub> High-impedance off-state output current	V <sub>O</sub> = 2.5 V			20	μA
	V <sub>O</sub> = 0.5 V			-20	
I <sub>CC</sub> Quiescent supply current	I <sub>O</sub> = 0, V <sub>I</sub> = 0 V or 5 V			100	μA
	I <sub>O</sub> = 0, V <sub>I</sub> = 2.4 V or 0.5 V, See Note 2		1.5	3	
C <sub>i</sub> Input capacitance			6		pF

† All typical values are at V<sub>CC</sub> = 5 V and T<sub>A</sub> = 25°C.

‡ Δ|V<sub>OD</sub>| and Δ|V<sub>OC</sub>| are the changes in magnitude of V<sub>OD</sub> and V<sub>OC</sub>, respectively, that occur when the input is changed from a high level to a low level.

NOTE 2: This parameter is measured per input. All other inputs are at 0 or 5 V.

**switching characteristics over recommended ranges of supply voltage and operating free-air temperature (unless otherwise noted)**

PARAMETER	TEST CONDITIONS	AM26C31C AM26C31I			UNIT
		MIN	TYP†	MAX	
t <sub>PLH</sub> Propagation delay time, low- to high-level output	S1 is open, See Figure 2	3	7	12	ns
t <sub>PHL</sub> Propagation delay time, high- to low-level output		3	7	12	ns
t <sub>sk(p)</sub> Pulse skew time ( t <sub>PLH</sub> - t <sub>PHL</sub>  )			0.5	4	ns
t <sub>r(OD)</sub> , t <sub>f(OD)</sub> Differential output rise and fall times	S1 is open, See Figure 3		5	10	ns
t <sub>PZH</sub> Output enable time to high level	S1 is closed, See Figure 4		10	19	ns
t <sub>PZL</sub> Output enable time to low level			10	19	ns
t <sub>PHZ</sub> Output disable time from high level			7	16	ns
t <sub>PLZ</sub> Output disable time from low level			7	16	ns
C <sub>pd</sub> Power dissipation capacitance (each driver) (see Note 3)	S1 is open, See Figure 2		170		pF

† All typical values are at V<sub>CC</sub> = 5 V and T<sub>A</sub> = 25°C.

NOTE 3: C<sub>pd</sub> is used to estimate the switching losses according to P<sub>D</sub> = C<sub>pd</sub> × V<sub>CC</sub><sup>2</sup> × f, where f is the switching frequency.

# AM26C31C, AM26C31I, AM26C31M QUADRUPLE DIFFERENTIAL LINE DRIVERS

SLLS103G – DECEMBER 1990 – REVISED SEPTEMBER 1998

**electrical characteristics over recommended ranges of supply voltage and operating free-air temperature (unless otherwise noted)**

PARAMETER	TEST CONDITIONS	AM26C31M			UNIT
		MIN	TYP†	MAX	
V <sub>OH</sub> High-level output voltage	I <sub>O</sub> = -20 mA	2.2	3.4		V
V <sub>OL</sub> Low-level output voltage	I <sub>O</sub> = 20 mA		0.2	0.4	V
V <sub>OD</sub>   Differential output voltage magnitude	R <sub>L</sub> = 100 Ω, See Figure 1	2	3.1		V
Δ V <sub>OD</sub>   Change in magnitude of differential output voltage‡				±0.4	V
V <sub>OC</sub> Common-mode output voltage				3	V
Δ V <sub>OC</sub>   Change in magnitude of common-mode output voltage‡				±0.4	V
I <sub>I</sub> Input current	V <sub>I</sub> = V <sub>CC</sub> or GND			±1	μA
I <sub>O(off)</sub> Driver output current with power off	V <sub>CC</sub> = 0, V <sub>O</sub> = 6 V			100	μA
	V <sub>CC</sub> = 0, V <sub>O</sub> = -0.25 V			-100	
I <sub>OS</sub> Driver output short-circuit current	V <sub>O</sub> = 0			-170	mA
I <sub>OZ</sub> High-impedance off-state output current	V <sub>O</sub> = 2.5 V			20	μA
	V <sub>O</sub> = 0.5 V			-20	
I <sub>CC</sub> Quiescent supply current	I <sub>O</sub> = 0, V <sub>I</sub> = 0 V or 5 V			100	μA
	I <sub>O</sub> = 0, V <sub>I</sub> = 2.4 V or 0.5 V, See Note 2			3.2	
C <sub>i</sub> Input capacitance			6		pF

† All typical values are at V<sub>CC</sub> = 5 V and T<sub>A</sub> = 25°C.

‡ Δ|V<sub>OD</sub>| and Δ|V<sub>OC</sub>| are the changes in magnitude of V<sub>OD</sub> and V<sub>OC</sub>, respectively, that occur when the input is changed from a high level to a low level.

NOTE 2: This parameter is measured per input. All other inputs are at 0 V or 5 V.

**switching characteristics over recommended ranges of supply voltage and operating free-air temperature (unless otherwise noted)**

PARAMETER	TEST CONDITIONS	AM26C31M			UNIT
		MIN	TYP†	MAX	
t <sub>PLH</sub> Propagation delay time, low- to high-level output	S1 is open, See Figure 2		7	12	ns
t <sub>PHL</sub> Propagation delay time, high- to low-level output			6.5	12	
t <sub>sk(p)</sub> Pulse skew time ( t <sub>PLH</sub> - t <sub>PHL</sub>  )			0.5	4	
t <sub>r(OD)</sub> , t <sub>f(OD)</sub> Differential output rise and fall times	S1 is open, See Figure 3		5	12	ns
t <sub>PZH</sub> Output enable time to high level	S1 is closed, See Figure 4		10	19	ns
t <sub>PZL</sub> Output enable time to low level			10	19	
t <sub>PHZ</sub> Output disable time from high level			7	16	
t <sub>PLZ</sub> Output disable time from low level			7	16	
C <sub>pd</sub> Power dissipation capacitance (each driver) (see Note 3)	S1 is open, See Figure 2		100		pF

† All typical values are at V<sub>CC</sub> = 5 V and T<sub>A</sub> = 25°C.

NOTE 3: C<sub>pd</sub> is used to estimate the switching losses according to P<sub>D</sub> = C<sub>pd</sub> × V<sub>CC</sub><sup>2</sup> × f, where f is the switching frequency.

# AM26C31C, AM26C31I, AM26C31M QUADRUPLE DIFFERENTIAL LINE DRIVERS

SLLS103G – DECEMBER 1990 – REVISED SEPTEMBER 1998

## PARAMETER MEASUREMENT INFORMATION

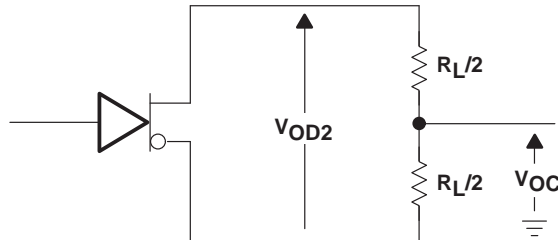
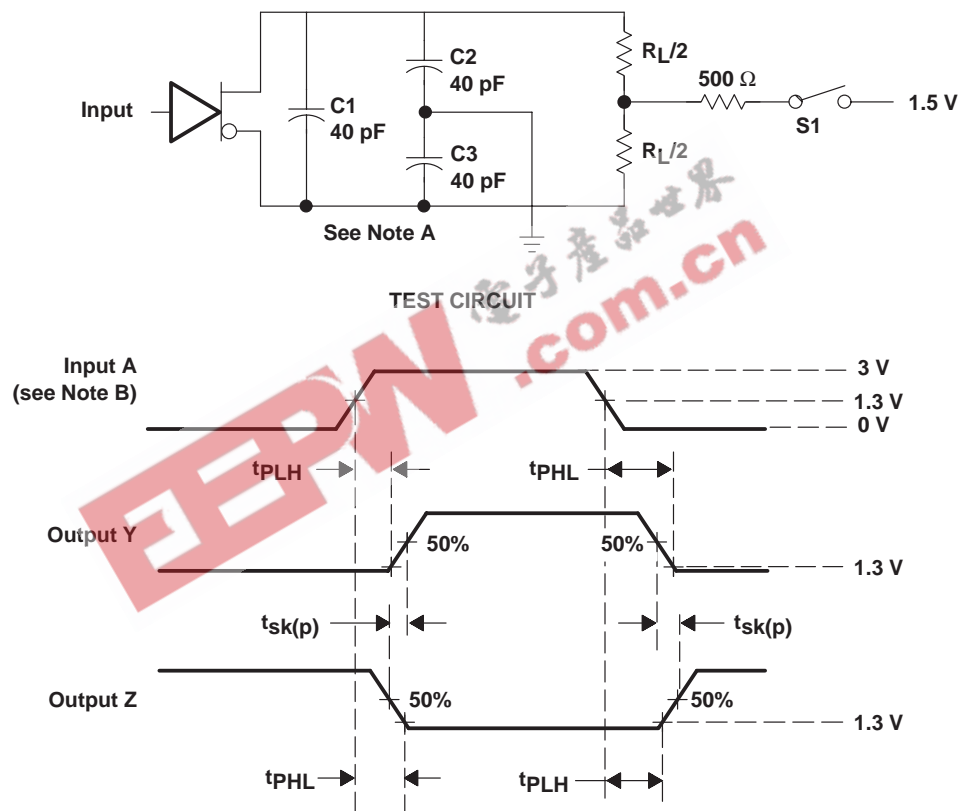

Figure 1. Differential and Common-Mode Output Voltages



- NOTES: A. C1, C2, and C3 include probe and jig capacitance.  
 B. All input pulses are supplied by generators having the following characteristics: PRR  $\leq$  1 MHz, duty cycle  $\leq$  50%, and  $t_r$   $t_f \leq$  6 ns.

Figure 2. Propagation Delay Time and Skew Waveforms and Test Circuit

# AM26C31C, AM26C31I, AM26C31M QUADRUPLE DIFFERENTIAL LINE DRIVERS

SLLS103G – DECEMBER 1990 – REVISED SEPTEMBER 1998

## PARAMETER MEASUREMENT INFORMATION

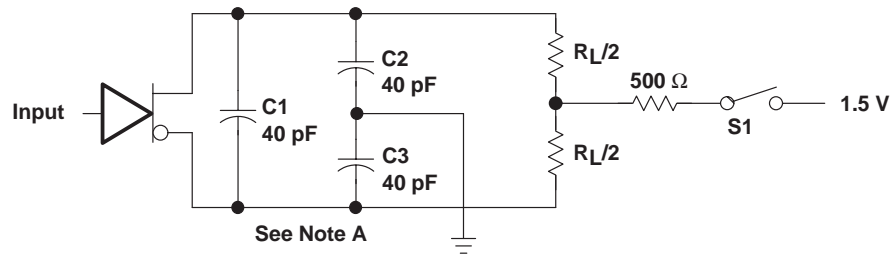

TEST CIRCUIT

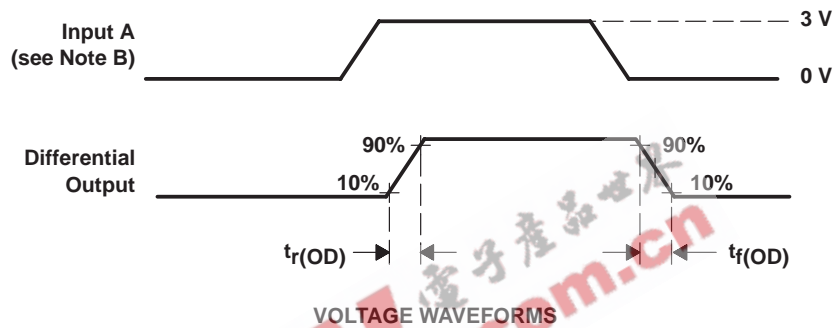

VOLTAGE WAVEFORMS

- NOTES: A. C1, C2, and C3 include probe and jig capacitance.  
 B. All input pulses are supplied by generators having the following characteristics: PRR  $\leq$  1 MHz, duty cycle  $\leq$  50%, and  $t_r, t_f \leq$  6 ns.

Figure 3. Differential Output Rise and Fall Time Waveforms and Test Circuit

# AM26C31C, AM26C31I, AM26C31M QUADRUPLE DIFFERENTIAL LINE DRIVERS

SLLS103G – DECEMBER 1990 – REVISED SEPTEMBER 1998

## PARAMETER MEASUREMENT INFORMATION

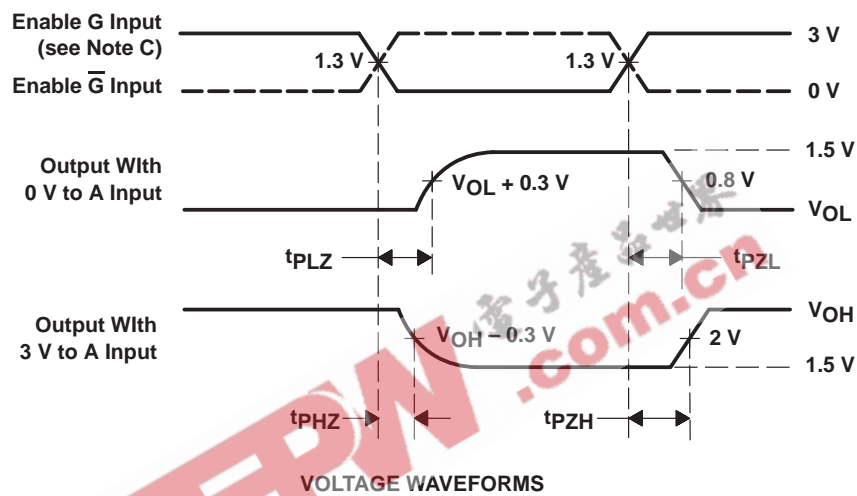
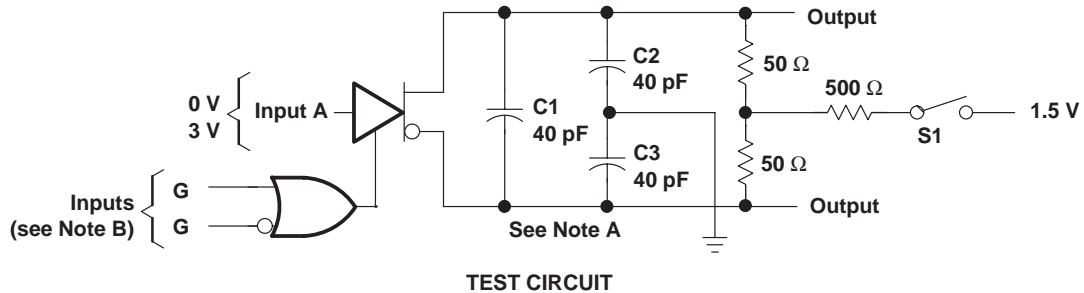

- NOTES: A. C1, C2, and C3 includes probe and jig capacitance.  
 B. All input pulses are supplied by generators having the following characteristics: PRR  $\leq$  1 MHz, duty cycle  $\leq$  50%,  $t_r <$  6 ns, and  $t_f <$  6 ns.  
 C. Each enable is tested separately.

**Figure 4. Output Enable and Disable Time Waveforms and Test Circuit**



# AM26C31C, AM26C31I, AM26C31M QUADRUPLE DIFFERENTIAL LINE DRIVERS

SLLS103G – DECEMBER 1990 – REVISED SEPTEMBER 1998

## TYPICAL CHARACTERISTICS

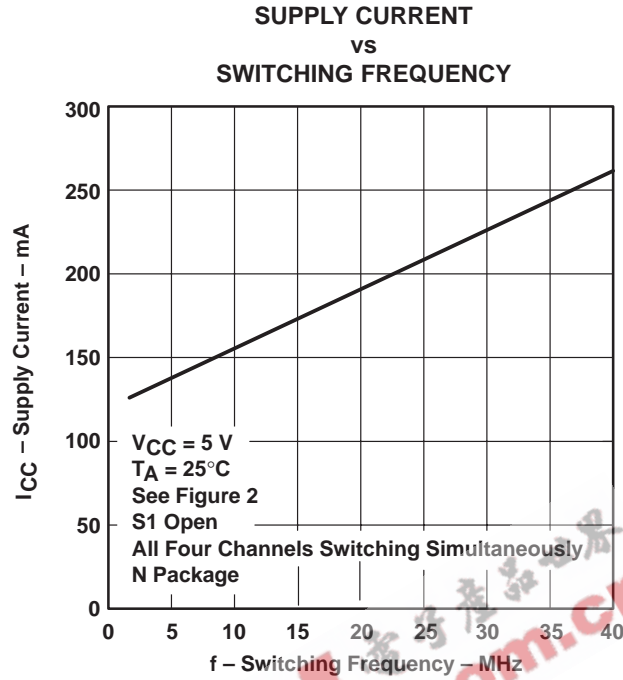

Figure 5

## IMPORTANT NOTICE

Texas Instruments and its subsidiaries (TI) reserve the right to make changes to their products or to discontinue any product or service without notice, and advise customers to obtain the latest version of relevant information to verify, before placing orders, that information being relied on is current and complete. All products are sold subject to the terms and conditions of sale supplied at the time of order acknowledgement, including those pertaining to warranty, patent infringement, and limitation of liability.

TI warrants performance of its semiconductor products to the specifications applicable at the time of sale in accordance with TI's standard warranty. Testing and other quality control techniques are utilized to the extent TI deems necessary to support this warranty. Specific testing of all parameters of each device is not necessarily performed, except those mandated by government requirements.

CERTAIN APPLICATIONS USING SEMICONDUCTOR PRODUCTS MAY INVOLVE POTENTIAL RISKS OF DEATH, PERSONAL INJURY, OR SEVERE PROPERTY OR ENVIRONMENTAL DAMAGE ("CRITICAL APPLICATIONS"). TI SEMICONDUCTOR PRODUCTS ARE NOT DESIGNED, AUTHORIZED, OR WARRANTED TO BE SUITABLE FOR USE IN LIFE-SUPPORT DEVICES OR SYSTEMS OR OTHER CRITICAL APPLICATIONS. INCLUSION OF TI PRODUCTS IN SUCH APPLICATIONS IS UNDERSTOOD TO BE FULLY AT THE CUSTOMER'S RISK.

In order to minimize risks associated with the customer's applications, adequate design and operating safeguards must be provided by the customer to minimize inherent or procedural hazards.

TI assumes no liability for applications assistance or customer product design. TI does not warrant or represent that any license, either express or implied, is granted under any patent right, copyright, mask work right, or other intellectual property right of TI covering or relating to any combination, machine, or process in which such semiconductor products or services might be or are used. TI's publication of information regarding any third party's products or services does not constitute TI's approval, warranty or endorsement thereof.