

# Silicon Miniature Single-Phase Bridge



## AM100-G/150-G thru AM1010-G/1510-G

**Voltage: 50 ~ 1000 Volts**

**Current: 1.0 ~ 1.5 Amp**

### Features:

- Ratings to 1000V PRV
- Surge overloading - 30/50 amperes peak
- Ideal for printed circuited board
- Reliable construction utilizing molded plastic
- Mounting position: Any

### Mechanical Data:

- Case: Reliable low cost construction utilizing molded plastic technique results in inexpensive product
- Terminals: Lead solderable per MIL-STD-202, Method 208  
Polarity: Polarity symbols marking on body
- Weight: 0.05 ounce, 1.3 grams
- Available with 0.50 inch leads (P/N add Suffix "S")

### Maximum Ratings and Electrical Characteristics

Rating at 25°C ambient temperature unless otherwise specified  
Single phase, half wave, 60Hz, Resistive or inductive load.

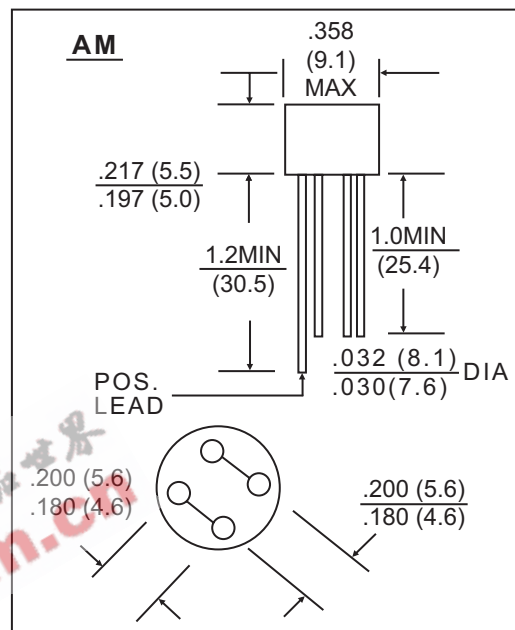

	AM100-G AM150-G	AM101-G AM151-G	AM102-G AM152-G	AM104-G AM154-G	AM106-G AM156-G	AM108-G AM158-G	AM1010-G AM1510-G	Units
For capacitive load, derate current by 20%								
Maximum Recurrent Peak Reverse Voltage	50	100	200	400	600	800	1000	V
Maximum RMS Bridge input Voltage	35	70	140	280	420	560	700	V
Maximum DC Blocking Voltage	50	100	200	400	600	800	1000	V
AM100 Maximum Average Forward Rectified Current at T <sub>A</sub> =50°C	1.0 1.5							A
Peak Forward Surge Current, 8.3ms single half sine-wave superimposed on rated load	30 50							A
Maximum Forward Voltage Drop per Bridge Element at 1.0A DC	1.0							V
Maximum Reverse Current at Rated T <sub>A</sub> =25°C	10.0							uA
DC Blocking Voltage per element T <sub>A</sub> =100°C	1.0							mA
I <sup>2</sup> t Rating for fusing (t<8.35ms)	10							A <sup>2</sup> S
Typical Junction Capacitance per leg (Note1) C <sub>J</sub>	24							pF
Typical Thermal resistance per leg (Note 2) R <sub>θJA</sub>	36							°C/W
Typical Thermal resistance per leg (Note 2) R <sub>θJL</sub>	13							
Operating Temperature Range T <sub>J</sub>	-55 to +125							°C
Storage Temperature Range T <sub>A</sub>	-55 to +150							°C

- Notes:
1. Measured at 1 MHz and applied reverse voltage of 4.0 Volts
  2. Thermal resistance from junction to ambient and from junction to lead mounted on P.C.B with 0.47x0.47 (12x12mm) copper pads

"-G" suffix designated RoHS compliant version

# Silicon Miniature Single-Phase Bridge

**COMCHIP**  
SMD DIODE SPECIALIST

AM100-G/150-G thru AM1010-G/1510-G

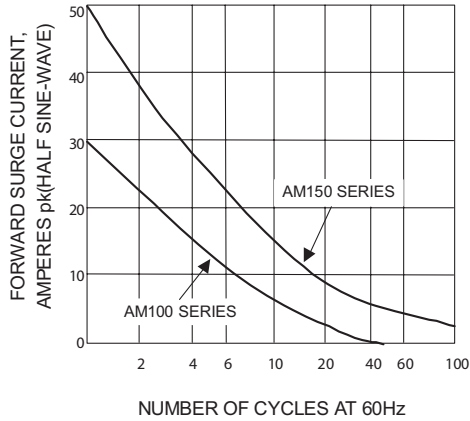

Fig. 1-MAXIMUM NON-REPETITIVE SURGE CURRENT

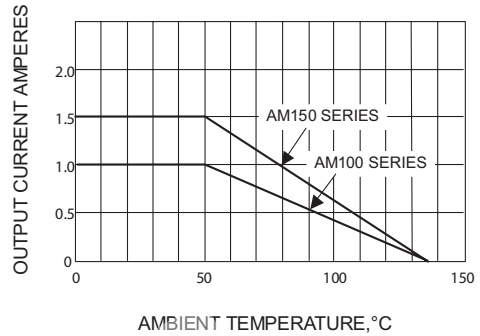

Fig. 2-DERATING CURVE FOR OUTPUT RECTIFIED CURRENT

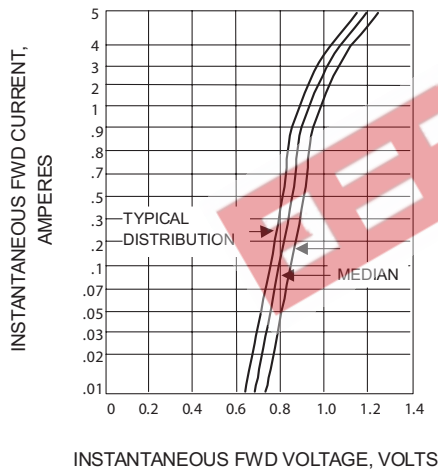

Fig. 3-TYPICAL FORWARD CHARACTERISTICS(25 °C)

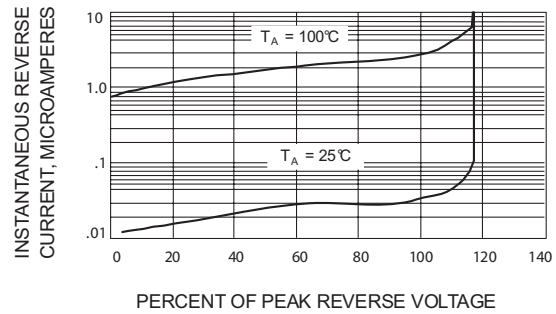

Fig. 4-TYPICAL REVERSE CHARACTERISTICS