



Product Features

- 60-3000 MHz Bandwidth
- +37 dBm Output IP3
- 2.4 dB Noise Figure
- 14 dB Gain
- +18 dBm P1dB
- MTBF >100 Years
- SOT-89 SMT Package
- Single Bias Supply (+3.3 to +4.5 V)



Actual Size

Product Description

The AM1 is a general purpose gain block that offers good dynamic range in a low cost surface mount package. The combination of flat IP3 and noise figure performance over frequency makes it attractive for both narrow and broad-band applications. Superior thermal design allows the product to achieve +37 dBm IP3 performance at a mounting temperature of +85°C with an associated MTBF of >100 years³. All devices are 100% RF and DC tested.

Functional Diagram

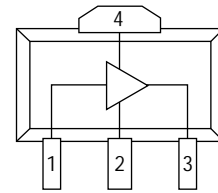

Function	Pin No.
Input	1
Ground	2
Output/Bias	3
Ground	4

Specifications

Parameter	Units	Min.	Typical	Max.
Frequency Range	MHz	60		3000
S21 - Gain	dB	13	14	16
S11 - Input Return Loss	dB		-9	
S22 - Output Return Loss	dB		-15	
Output IP3	dBm	+33	+37	
Output P1dB	dBm		+18	
Noise Figure	dB		2.4	
Operating Current Range	mA	55	75	100
Supply Voltage	V		4.5	

Test conditions unless otherwise noted.

1. T = 25°C, Vdd = 4.5 V, Frequency = 800 MHz, 50 Ω system.

2. OIP3 measured with two tones at an output power of 2 dBm/tone separated by 10 MHz. The suppression on the largest IM3 product is used to calculate the OIP3 using a 2:1 slope rule.

3. MTBF calculated with channel temperature at 155°C.

Absolute Maximum Ratings

Parameter	Rating
Operating Case Temperature	-40 to +85°C
Storage Temperature	-55 to +125°C
DC Voltage	+5.5 V
Input RF Power (continuous)	+7 dBm

Operation of this device above any of these parameters may cause permanent damage.

Typical Parameters

Parameter	Units	Typical	
Frequency	MHz	900	1900
S21	dB	13.4	12.2
S11	dB	-12.5	-13.2
S22	dB	-21.2	-17.8
Output IP3	dBm	+37.5	+37.0
Output P1dB	dBm	+18.1	+18.0
Noise Figure	dB	2.4	2.6

Typical specifications reflect AM1 measured on application circuit (AM1-PCB).

Ordering Information

Part No.	Description
AM1	High Dynamic Range Amplifier (Available in tape and reel)
AM1-PCB	Fully Assembled Application Circuit

Performance Charts (T = 22°C, unmatched device in a 50 ohm system)

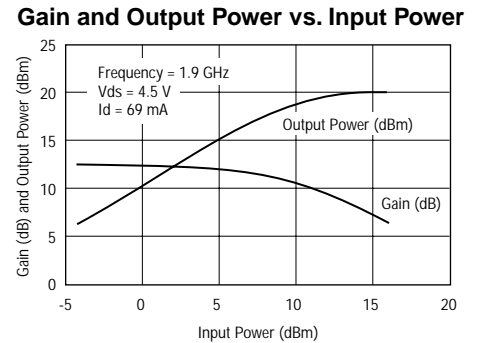
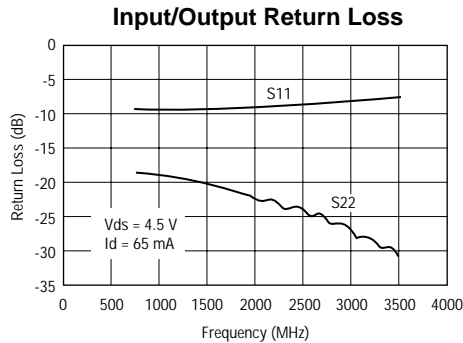
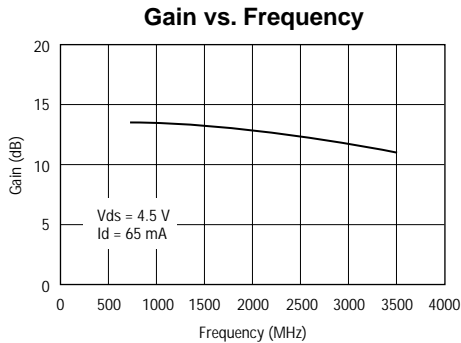

Application Circuit: 0.8 to 2.6 GHz (AM1-PCB)

Typical Specifications

	0.9 GHz	1.9 GHz	2.4 GHz
Frequency	0.9 GHz	1.9 GHz	2.4 GHz
Magnitude S21	13.4 dB	12.2 dB	11.5 dB
Magnitude S11	-12.5 dB	-13.2 dB	-11.4 dB
Magnitude S22	-21.2 dB	-17.8 dB	-17.3 dB
OIP3	37.0 dBm	37 dBm	37 dBm
Noise Figure	2.4 dB	2.6 dB	2.8 dBm
Bias	Vds = 4.5 V, Id = 75 mA		

Schematic

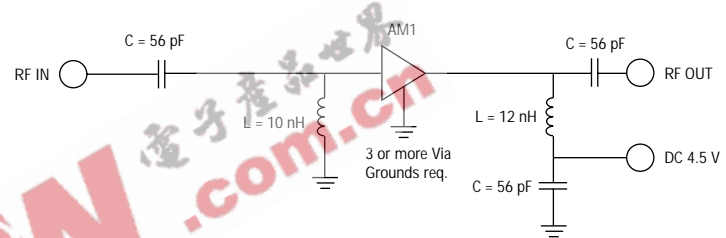

S-Parameters

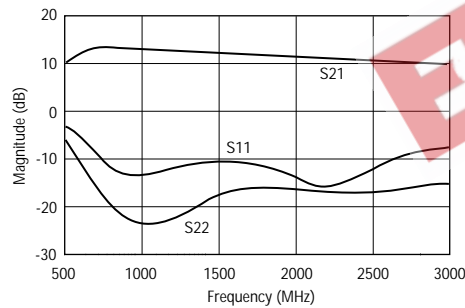

FR4 Board Layout (T = 14 Mils)

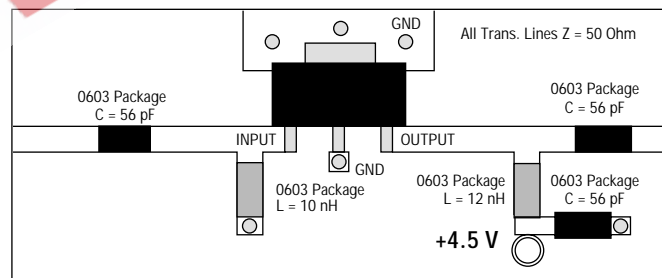

NOTE: The application circuit is designed for wide bandwidth. For narrow band applications, S11 and S21 can be improved with an input shunt microstrip element to ground.

Thermal Specifications

Parameter	Rating
Operating Case Temperature	-40 to +85°C
Thermal Resistance (Maximum)	88°C/W
Junction Temperature (Recommended Maximum)	+155°C

- Notes:
1. Thermal Resistance determined at Maximum Tab Temperature and Maximum Power Dissipation.
 2. Recommended Maximum Junction Temperature insures a MTBF of 1 million hours.
 3. Refer to WJ Application Note "AM1 Temperature Effects on Reliability" for more information.

MTBF vs. Temperature

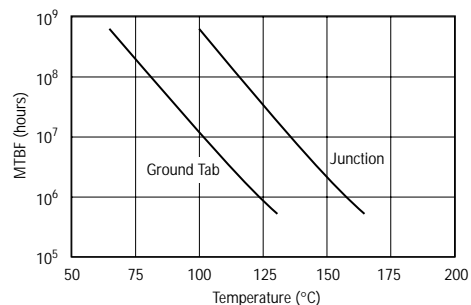

Application Circuit: 60 - 100 MHz

Typical Specifications

Frequency	70 MHz
Magnitude S21	16.3 dB
Magnitude S11	-17.1 dB
Magnitude S22	-15.6 dB
Noise Figure	5.1 dB
Bias Supply	4.5 V @ 75 mA

Schematic

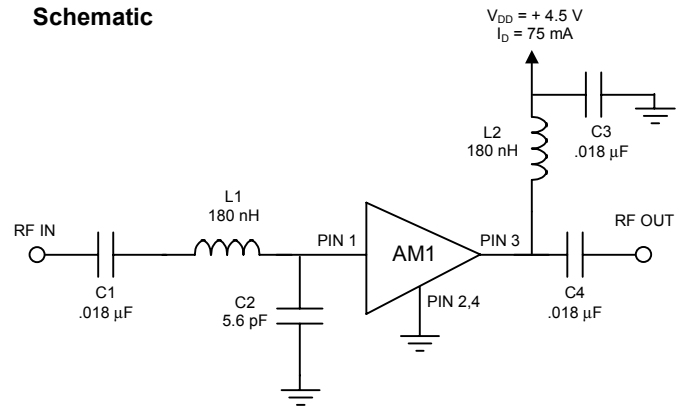

S-Parameters

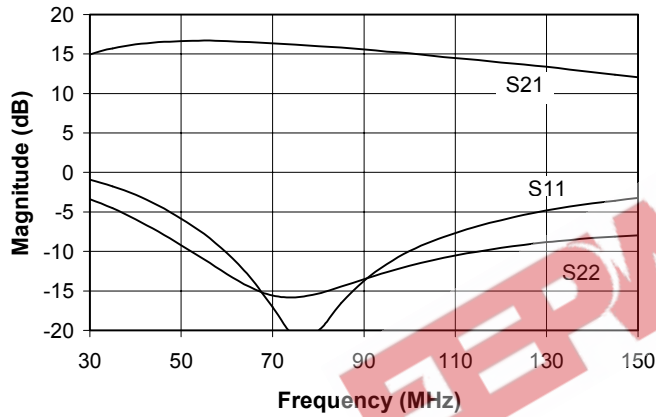

Noise Figure

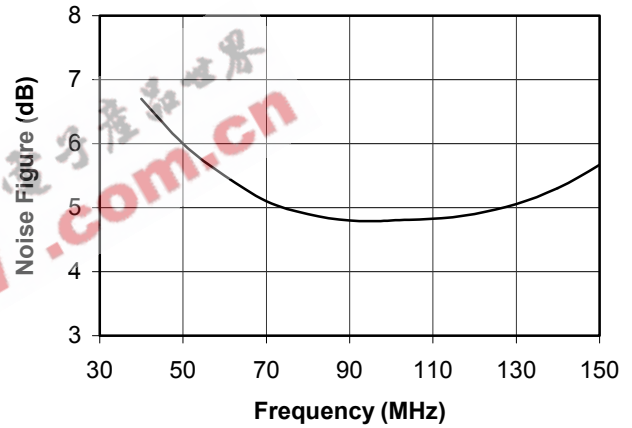

Outline Drawing

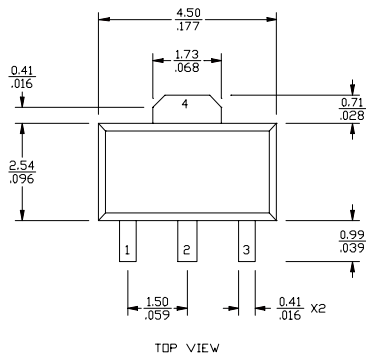

mm
inch

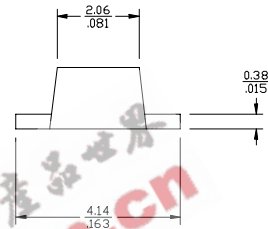
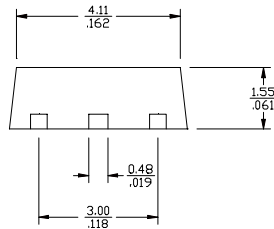

Land Pattern

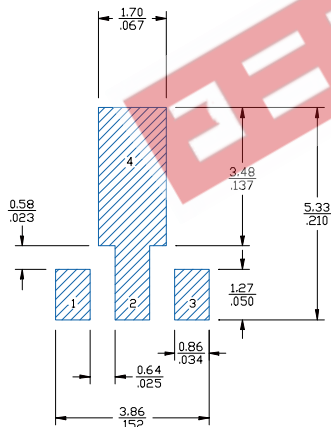

Mounting Configuration

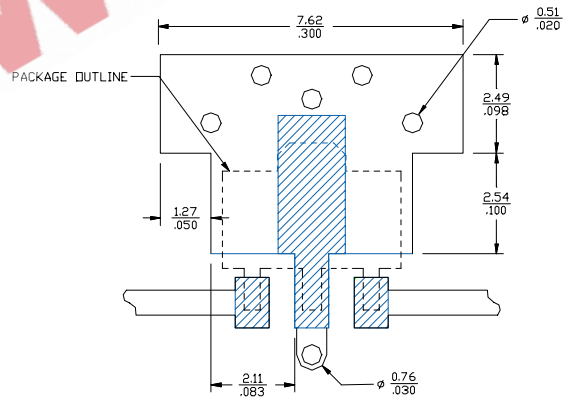

FUNCTION	PIN NO.
INPUT	1
GROUND	2
OUTPUT (BIAS)	3
GROUND	4

- Notes:
1. Ground vias are critical for thermal and RF grounding considerations.
 2. A minimum of 6 ground vias are required for 14 mil and 28 mil FR4 board.
 3. If your PCB design rules allow, ground vias should be placed under the land pattern for better RF and thermal performance. Otherwise ground vias should be placed as close to land pattern as possible.
 4. Trace width depends on PC board.

Specifications and information are subject to change without notice.



Caution! ESD sensitive device.

Typical Test Data

S-Parameters (V_{ds} = +4.5 V, I_{ds} = 75 mA, T = 22°C, unmatched device in a 50 ohm system)

Freq (MHz)	S11 (Mag)	S11 (Ang)	S21 (Mag)	S21 (Ang)	S12 (Mag)	S12 (Ang)	S22 (Mag)	S22 (Ang)
250	0.499	-26.60	4.732	163.00	0.091	7.59	0.292	-24.50
350	0.483	-29.90	4.677	160.00	0.092	2.17	0.275	-23.50
450	0.473	-34.20	4.624	156.00	0.093	-1.66	0.263	-23.80
550	0.466	-39.20	4.624	152.00	0.093	-4.84	0.257	-25.00
650	0.459	-44.60	4.571	148.00	0.093	-7.70	0.248	-27.00
750	0.453	-50.30	4.571	143.00	0.094	-10.40	0.243	-29.20
850	0.447	-56.10	4.467	139.00	0.094	-12.90	0.234	-31.50
950	0.441	-62.30	4.467	134.00	0.094	-15.40	0.229	-34.30
1050	0.435	-68.60	4.467	130.00	0.094	-17.90	0.221	-37.50
1150	0.347	-74.23	4.576	132.39	0.096	-18.13	0.108	-27.27
1250	0.345	-80.74	4.537	128.65	0.096	-20.21	0.102	-27.41
1350	0.351	-86.61	4.492	124.94	0.096	-22.23	0.100	-27.26
1450	0.351	-91.21	4.450	121.26	0.095	-24.21	0.098	-30.03
1550	0.351	-97.34	4.406	117.51	0.095	-26.26	0.093	-29.92
1650	0.357	-102.70	4.357	113.92	0.094	-28.09	0.094	-30.82
1750	0.357	-107.50	4.321	110.26	0.094	-30.05	0.089	-33.77
1850	0.360	-113.99	4.265	106.53	0.093	-32.01	0.086	-32.21
1950	0.368	-118.52	4.222	103.05	0.093	-33.81	0.087	-36.15
2050	0.366	-124.10	4.178	99.26	0.092	-35.95	0.078	-37.29
2150	0.375	-129.50	4.115	95.85	0.091	-37.66	0.081	-36.43
2250	0.380	-133.90	4.081	92.16	0.091	-39.71	0.077	-42.91
2350	0.378	-139.40	4.018	88.51	0.090	-41.70	0.073	-39.88
2450	0.395	-144.55	3.984	85.14	0.089	-43.45	0.076	-45.37
2550	0.394	-148.39	3.928	81.27	0.088	-45.65	0.067	-46.63
2650	0.391	-154.12	3.868	77.98	0.087	-47.48	0.070	-45.24
2750	0.410	-159.49	3.828	74.36	0.087	-49.46	0.065	-52.31
2850	0.405	-162.27	3.757	70.85	0.085	-51.43	0.060	-49.00
2950	0.407	-168.06	3.713	67.63	0.085	-53.15	0.062	-52.88
3050	0.421	-172.65	3.655	64.07	0.083	-55.23	0.055	-56.02
3150	0.419	-175.62	3.597	60.85	0.082	-56.91	0.055	-55.16
3250	0.423	178.73	3.560	57.48	0.081	-58.82	0.052	-59.73
3350	0.432	174.86	3.501	54.10	0.080	-60.67	0.049	-59.49
3450	0.432	170.90	3.458	50.87	0.079	-62.36	0.048	-60.99