

Single Band T/R Antenna Switch Module 800–1000 MHz



AM114-609

Applications

- Transmit/Receive Antenna Switch for Wireless System with Integrated LPF and Coupler for Power Detection

Features

- LTCC Technology Integrating LPF/Coupler
- GaAs PHEMT Switch Technology
- SMD Package, 5.2 x 4 x 1.7 mm
- Single Control with Low Current Consumption

Description

The AM114-609 is a high power antenna switch with an LTCC low pass filter and LTCC coupler included for power detection. The switches are PHEMT GaAs FETs that can operate at 2.5 V with low DC current drain.

Outline Drawing

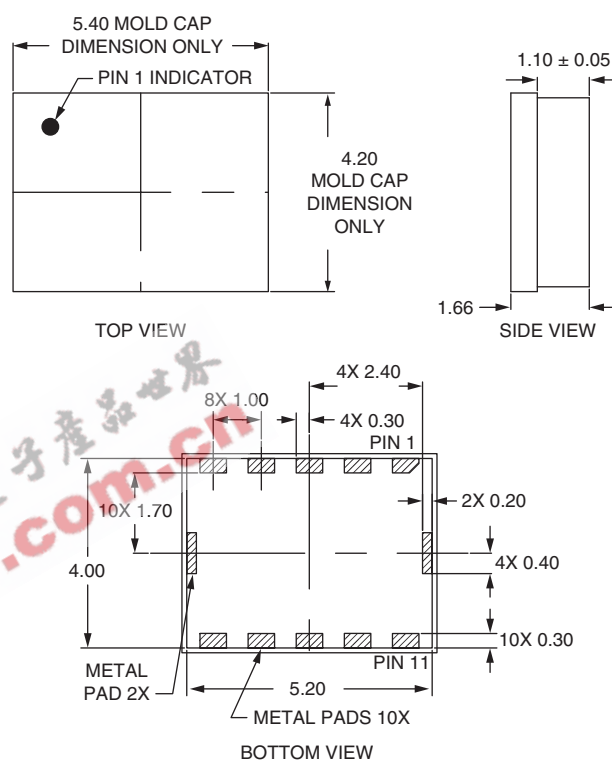

Dimensions in mm. Tolerance ± 0.2 unless otherwise specified.

Electrical Specifications @ 25°C

Receive Path

Parameter	Min.	Typ.	Max.	Unit
Frequency Range	851		941	MHz
Insertion Loss		0.6	0.8	dB
VSWR In-Band		1.5:1		
RF Input Power			0	dBm
R _X Current @ V _S = 3 V		30		μA
Supply Voltage (V _S)	2.7	3.0	5.0	V

Transmit Path

Parameter	Min.	Typ.	Max.	Unit
Frequency Range	806		928	MHz
Insertion Loss		0.8	1.0	dB
Isolation $T_X - R_X$ in T_X Mode ($V_{CTL} = 0$ V)		25		dB
Inter-modulation 3rd/5th Order		-60		dBc
Inter-modulation 3rd/5th Order – Under VSWR		-55		dBc
Input VSWR In-Band		1.5:1		
Harmonic Rejection		15		dB
$2 \cdot F_O$		20		dB
$3 \cdot F_O$				
Directivity		15		dB
Coupling Factor	19	20	21	dB
T_X Current		150		μ A
Supply Voltage (V_S)	2.7	3.0	5.0	V
RF Input Power		3.0		dBm

Absolute Maximum Ratings

Characteristic	Value
Operating Temperature Range (T_{OP})	-30 to +85°C
Storage Temperature Range (T_{STG})	-40 to +85°C
Input Power (P_{IN})	38 dBm
Control Voltage Logic 0	-0.1 to 0.2 V
Supply Voltage (V_S)	5 V
Nominal I/O Impedance (T_X, R_X, Ant)	50 Ω

Typical Performance Data

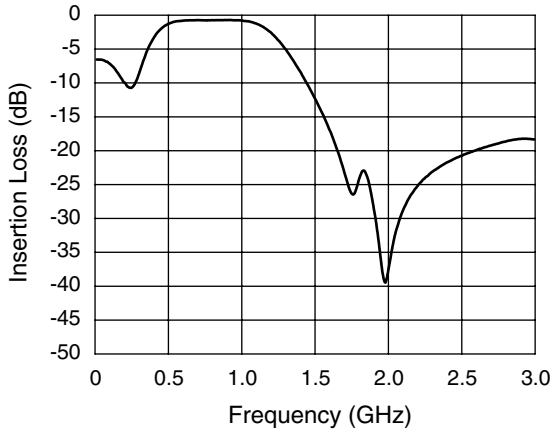

T_X Insertion Loss vs. Frequency

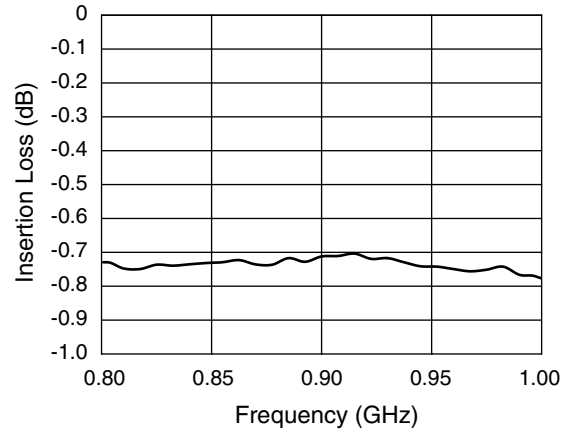

T_X Insertion Loss vs. Frequency

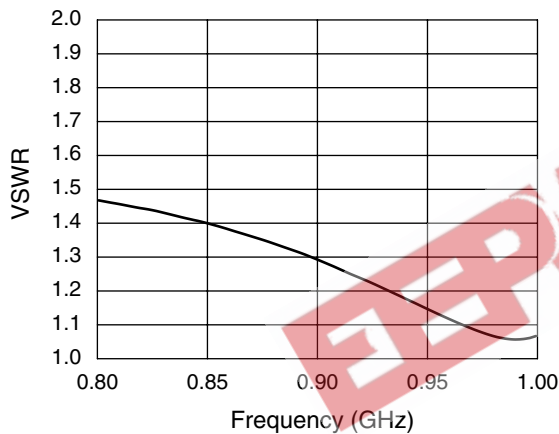

T_X VSWR vs. Frequency

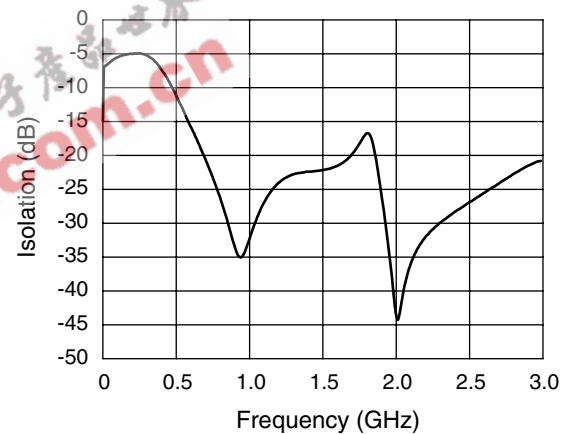

T_X to R_X Isolation vs. Frequency

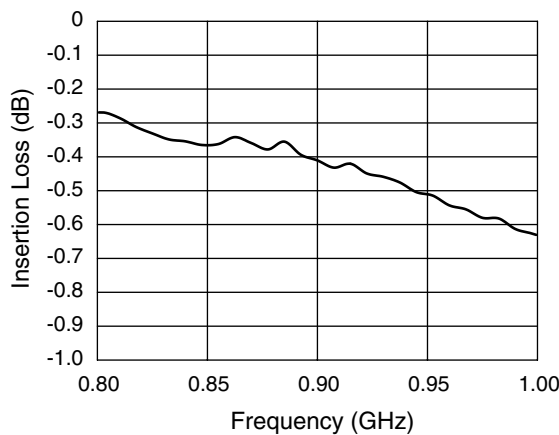

R_X Insertion Loss vs. Frequency

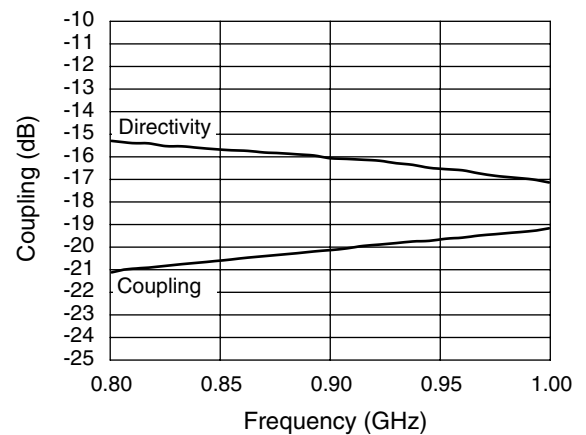

Coupling vs. Frequency

Pin Out (Top View)

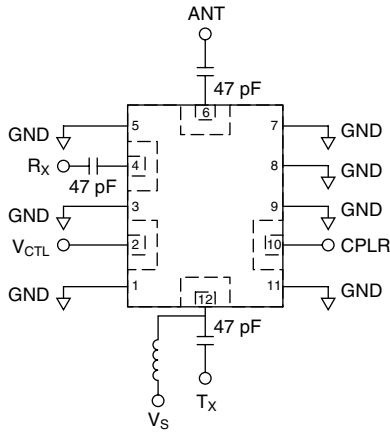

Blocking capacitors (47 pF) and inductor (82 nH) to be supplied externally.

Pin Out Table

Pin	Description	Pin	Description
1	GND	7	GND
2	V _{CTL}	8	GND
3	GND	9	GND
4	R _X	10	Coupler
5	GND	11	GND
6	Ant	12	T _X

Suggested Land Pattern

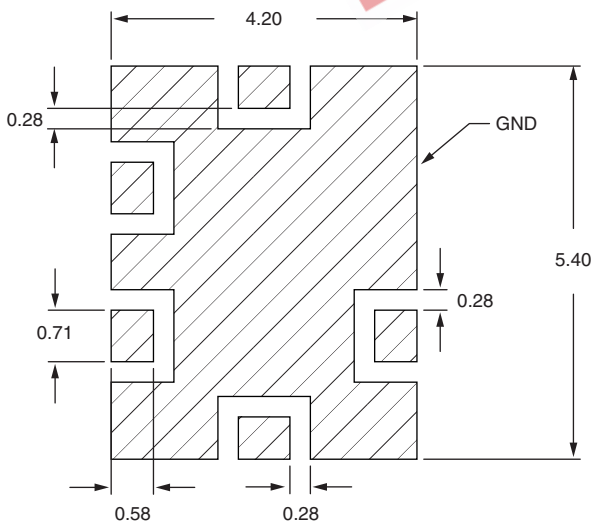

Dimensions are in mm.

Truth Table

Mode	V _{CTL}
T _X	0
R _X	Open Circuit

V_S = 2.7 to 5 V supplied externally to T_X port.

Block Diagram

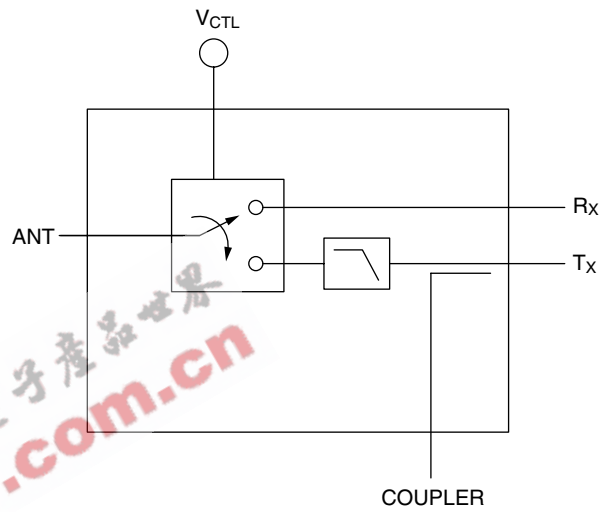

Evaluation PCB

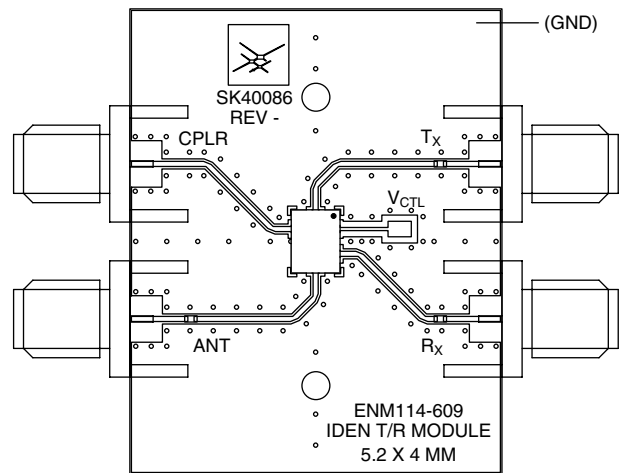

PCB # SK40086, Material: FR4, Dielectric constant: 4.1. The circuit board used in the final application should employ RF circuit design techniques. RF signal lines should have 50 Ω impedance. The package bottom ground plane should be connected directly to PCB ground plane. A sufficient number of via holes should be used to connect the top and bottom ground planes of the PCB. The evaluation circuit board shown is available upon request.