



Am79C989

Quad Ethernet Switching Transceiver (QuEST™)

DISTINCTIVE CHARACTERISTICS

- Four independent 10BASE-T transceivers compliant with the IEEE 802.3 standard
- Four digital Manchester Encode/Decode (MENDEC) units
- On-chip filtering enables FCC EMI compliance without external filters or common mode chokes
- Automatic polarity Correction and Detection on 10BASE-T receivers
- Optional Attachment Unit Interface (AUI) for non-10BASE-T transceivers
- 10BASE-T Extended Distance option accommodate lines longer than 100 meters
- Quad AMD Switching Interface (QuASI™) interface reduces overall pin count
- Half-Duplex and Full-Duplex operation
- Auto-Negotiation compliant with IEEE 802.3u Standard
- Standard MII management interface and protocol
- Status Change Interrupt output pin for fast response time to changed conditions
- 44-pin PLCC CMOS device
- 5 V supply with 3.3 V system interface compatibility

GENERAL DESCRIPTION

The Am79C989 Quad Ethernet Switching Transceiver (QuEST™) is a four-port physical layer (PHY) device that provides all of the analog functions needed for a 10BASE-T switch, including four independent Manchester Encode/Decode units (MENDECs) and four independent 10BASE-T transceivers. If the AUI port is used for a 10BASE-2, 10BASE-5, or 10BASE-FL transceiver, one of the four 10BASE-T ports is disabled.

The QuEST device is designed for 10 Mbps Ethernet switching hubs, port switching repeater hubs, routers, bridges, and servers that require data encoding and clock recovery on a per port basis and are limited by pin constraints. Clock recovery is performed as part of the MENDEC function. The QuEST device supports every physical layer function of a full-featured switch, including full-duplex operation with Auto-Negotiation and the ability to use various media types.

A unique feature of the QuEST device is the Quad AMD Switching Interface (QuASI) which multiplexes the data for all four channels into one set of pins. This minimizes the pin count and size of the QuEST device and substantially reduces overall system cost.

The QuEST device provides a 2-pin Media Independent Interface (MII) Management Interface which supports the protocols specified in the IEEE 802.3u standard. Controlled by the switch system, this interface allows the QuEST device to be polled for status information and allows operating parameters of the QuEST device, such as extended distance operation, to be altered.

The Am79C989 device provides an Interrupt pin to indicate changes in the internal status of the device. The interrupt function reduces CPU polling of status registers and allows fast response time to changes in physical layer conditions.

BLOCK DIAGRAM

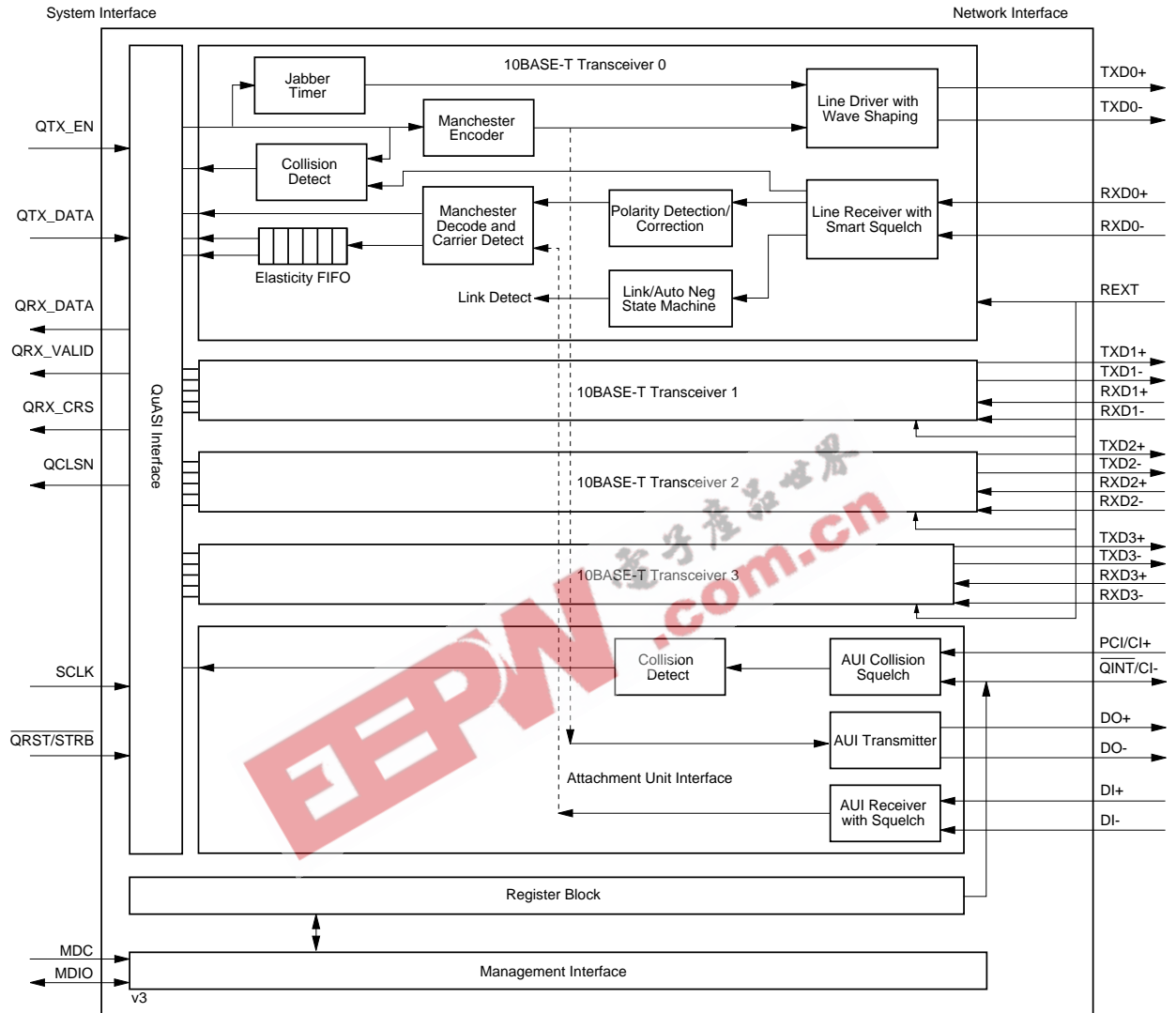

21173B-1

CONNECTION DIAGRAM

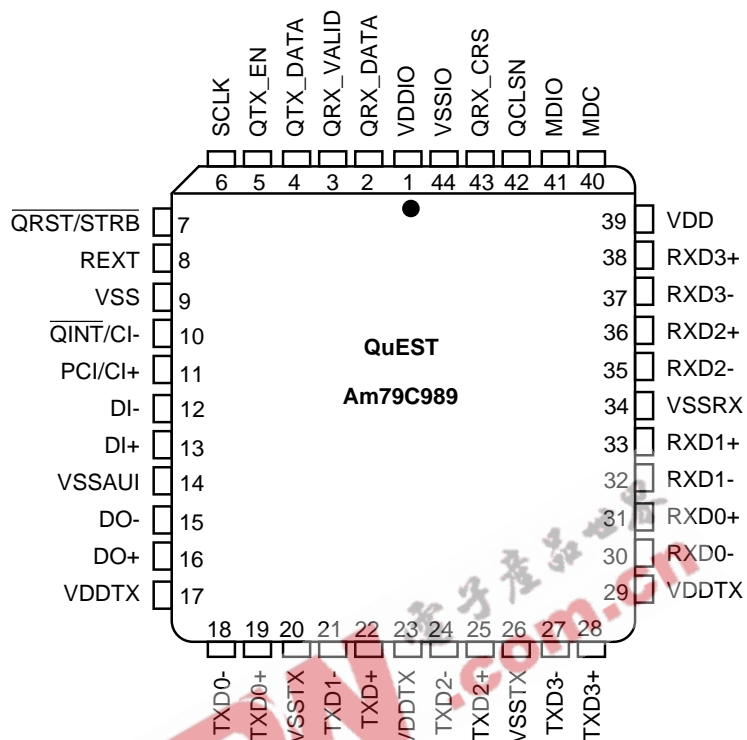

21173B-2

LOGIC DIAGRAM

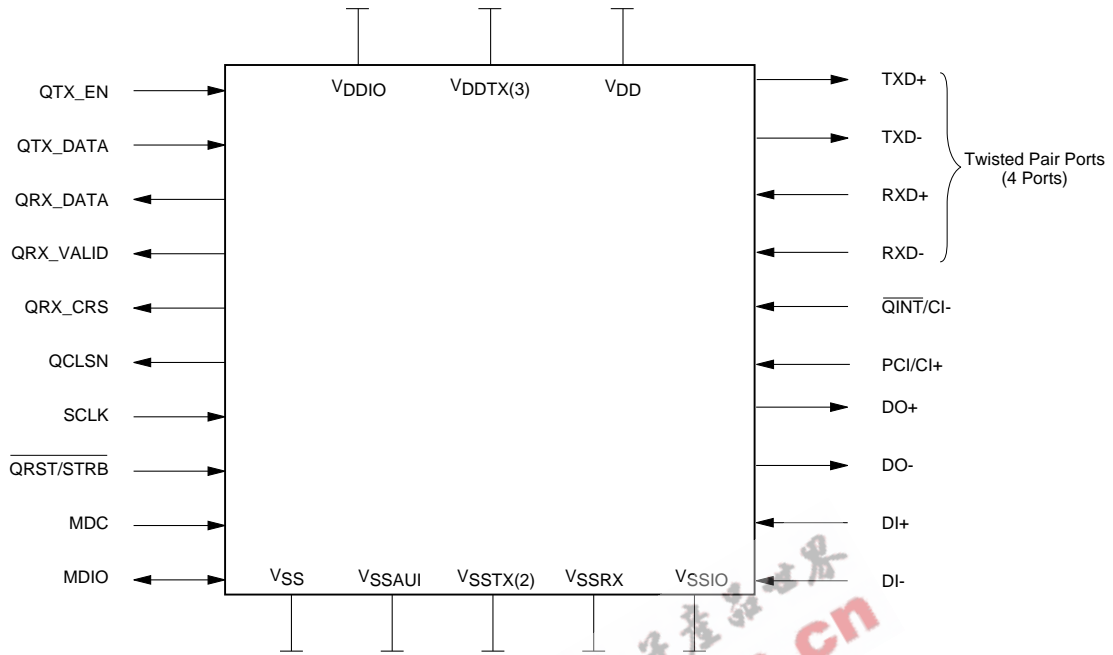

21173B-3

LOGIC SYMBOL

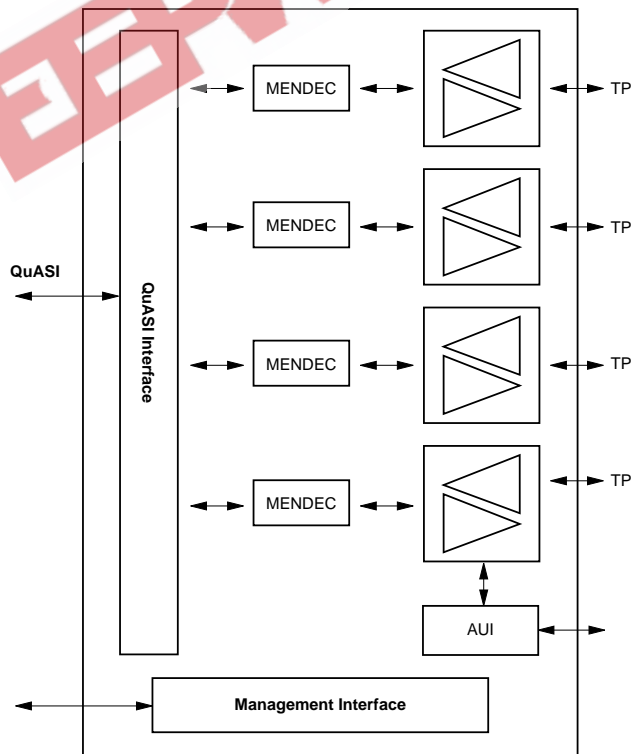

21173B-4

RELATED PRODUCTS

Part No.	Description
Am7990	Local Area Network Controller for Ethernet (LANCE)
Am7992B	Serial Interface Adapter (SIA)
Am7996	IEEE 802.3/Ethernet/Cheapernet Transceiver
Am79C90	CMOS Local Area Network Controller for Ethernet (C-LANCE)
Am79C98	Twisted Pair Ethernet Transceiver (TPEX)
Am79C100	Twisted Pair Ethernet Transceiver Plus (TPEX+)
Am79C870	Quad Fast Ethernet Transceiver (QFEX™) for 100BASE-X
Am79C871	Quad Fast Ethernet Transceiver for 100BASE-X Repeater (QFEXr™)
Am79C981	Integrated Multiport Repeater Plus (IMR+™)
Am79C982	basic Integrated Multiport Repeater (bIMR™)
Am79C983	Integrated Multiport Repeater 2 (IMR2™)
Am79C984A	enhanced Integrated Multiport Repeater (eIMR™)
Am79C985	enhanced Integrated Multiport Repeater Plus (eIMR+™)
Am79C987	Hardware Implemented Management Information Base (HIMIB™)
Am79C988	Quad Integrated Ethernet Transceiver (QuiET™)
Am79C900	Integrated Local Area Communications Controller (ILACC™)
Am79C940	Media Access Controller for Ethernet (MACE™)
Am79C960	PCnet™-ISA Single-Chip Ethernet Controller (for ISA bus)
Am79C961	PCnet™-ISA+ Single-Chip Ethernet Controller for ISA (with Microsoft® Plug n' Play® Support)
Am79C961A	PCnet™-ISA II Full Duplex Single-Chip Ethernet Controller for ISA
Am79C965	PCnet™-32 Single-Chip 32-Bit Ethernet Controller
Am79C970	PCnet™-PCI Single-Chip Ethernet Controller (for PCI bus)
Am79C970A	PCnet™-PCI II Full Duplex Single-Chip Ethernet Controller (for PCI bus)
Am79C971B	PCnet™-FAST Single-Chip Full-Duplex 10/100 Mbps Ethernet Controller for PCI Local Bus
Am79C974	PCnet™-SCSI Combination Ethernet and SCSI Controller for PCI Systems

ORDERING INFORMATION

Standard Products

AMD standard products are available in several packages and operating ranges. The order number (Valid Combination) is formed by a combination of the elements below.

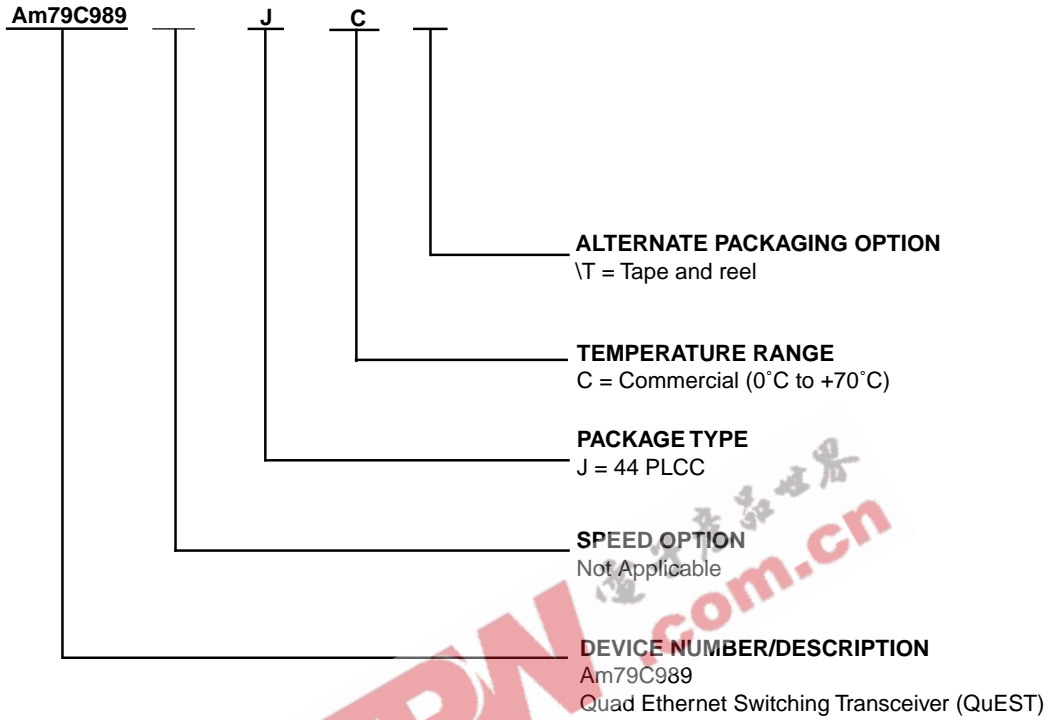

Valid Combinations	
Am79C989	JC or JCT

Valid Combinations

Valid Combinations list configurations planned to be supported in volume for this device. Consult the local AMD sales office to confirm availability of specific valid combinations and to check on newly released combinations.

TABLE OF CONTENTS

DISTINCTIVE CHARACTERISTICS	1
GENERAL DESCRIPTION	1
BLOCK DIAGRAM	2
CONNECTION DIAGRAM	3
LOGIC DIAGRAM	4
LOGIC SYMBOL	4
RELATED PRODUCTS	5
ORDERING INFORMATION	6
Standard Products	6
PIN DESIGNATIONS	9
Listed by Pin Number	9
Listed by Group	9
PIN DESCRIPTIONS	11
10BASE-T Signal Pins	11
AUI Signal Pins	11
QuASI Interface Pins	11
Management Interface Pins	12
Miscellaneous Pins	12
Power Pins	12
FUNCTIONAL DESCRIPTION	13
Overview	13
10BASE-T Interface	13
10BASE-T Transmitter	13
Driver	13
Jabber Condition	13
10BASE-T Receiver	14
Differential Receiver	14
Receive Polarity Correction	14
Extended Distance	14
Collision	14
Link Integrity with Auto-Negotiation	14
General	14
10BASE-T Algorithm	15
Auto-Negotiation Algorithm	15
Manchester Encoder	15
Manchester Decoder	15
Elasticity FIFO	15
Attachment Unit Interface (AUI)	15
General	15
AUI Transmitter	16
AUI Receiver	16
Collision	16
QuASI Interface	16
Management Interface	17
The Management Frame	17
PHY Addressing	17
Interrupt Function	18
3.3 Volt Operation	18
REGISTER DESCRIPTION	18
Shared Registers	18
Port Registers	19
Non-Implemented Registers	19
Auto-Negotiation Control Register (Reg 0)	19
Auto-Negotiation Status Register (Reg 1)	20
Auto-Negotiation Advertisement Register (Reg 4)	21
Auto-Negotiation Link Partner Ability Register (Reg 5)	22

Auto-Negotiation Next Page Register (Reg 7).....	23
Error Mask Register (Reg 20).....	27
SYSTEM APPLICATIONS	28
10 Mbps Ethernet Switch.....	28
ABSOLUTE MAXIMUM RATINGS	29
OPERATING RANGES	29
Commercial (C) Devices.....	29
DC CHARACTERISTICS OVER OPERATING RANGES UNLESS OTHERWISE SPECIFIED. ...	29
KEY TO SWITCHING WAVEFORMS	31
PHYSICAL DIMENSIONS	37

EEPW 电子產品世界
.com.cn

PIN DESIGNATIONS**Listed by Pin Number**

Pin No.	Pin Name	Pin No.	Pin Name	Pin No.	Pin Name	Pin No.	Pin Name
1	VDDIO	12	DI-	23	VDDTX	34	VSSRX
2	QRX_DATA	13	DI+	24	TXD2-	35	RXD2-
3	QRX_VALID	14	VSSAUI	25	TXD2+	36	RXD2+
4	QTX_DATA	15	DO-	26	VSSTX	37	RXD3-
5	QTX_EN	16	DO+	27	TXD3-	38	RXD3+
6	SCLK	17	VDDTX	28	TXD3+	39	VDD
7	QRST/STRB	18	TXD0-	29	VDDTX	40	MDC
8	REXT	19	TXD0+	30	RXD0-	41	MDIO
9	VSS	20	VSSTX	31	RXD0+	42	QCLSN
10	QINT/CI-	21	TXD1-	32	RXD1-	43	QRX_CRS
11	PCI/CI+	22	TXD1+	33	RXD1+	44	VSSIO

Listed by Group

Pin Number	Pin Name	Pin Type	Pin Description
10BASE-T Signal Pins			
19 & 18	TXD0±	Output	Port 0 10BASE-T differential driver
22 & 21	TXD1±	Output	Port 1 10BASE-T differential driver
25 & 24	TXD2±	Output	Port 2 10BASE-T differential driver
28 & 27	TXD3±	Output	Port 3 10BASE-T differential driver
31 & 30	RXD0±	Input	Port 0 10BASE-T differential receiver
33 & 32	RXD1±	Input	Port 1 10BASE-T differential receiver
36 & 35	RXD2±	Input	Port 2 10BASE-T differential receiver
38 & 37	RXD3±	Input	Port 3 10BASE-T differential receiver
AUI Signal Pins			
10	QINT/CI-	I/O	AUI differential collision receiver negative signal or Interrupt output signal (open drain)
11	PCI/CI+	Input	AUI differential collision receiver positive signal or single-ended Pseudo AUI receiver
13 & 12	DI±	Input	Attachment Unit Interface differential data receiver
16 & 15	DO±	Output	Attachment Unit Interface differential output driver
QuASI Interface			
2	QRX_DATA	I/O	Multiplexed serial receive data PHYAD 4 internal address input upon reset
3	QRX_VALID	I/O	Multiplexed receive data valid enable PHYAD 3 internal address input upon reset
4	QTX_DATA	Input	Multiplexed serial transmit data
5	QTX_EN	Input	Multiplexed transmit enable

Pin Number	Pin Name	Pin Type	Pin Description
QuASI Interface (Continued)			
42	QCLSN	I/O	Multiplexed collision error PHYAD 2 internal address input upon reset
43	QRX_CRS	Output	Multiplexed receive carrier sense
Management Interface			
40	MDC	Input	Management Interface Clock
41	MDIO	I/O	Management Interface Data
Miscellaneous Pins			
6	SCLK	Input	System Clock for QuASI Interface
7	$\overline{\text{QRST/STRB}}$	Input	Active Low -- Reset and QuASI Channel 0 strobe
8	REXT	Input	External resistor for determining TXD drive levels
Power Pins			
1	VDDIO	VDD1	1 VDD pin for digital Outputs (3.3 Volt Capable)
44	VSSIO	VSS	1 VSS pin for digital Inputs/Outputs
39	VDD	VDD	1 VDD pin for internal digital logic
9	VSS	VSS	1 VSS pin for internal digital logic
14	VSSAUI	VSS	1 Analog VSS pin for AUI circuit
29, 23, 17	VDDTX	VDD	3 Analog VDD pins for TXD driver
26, 20	VSSTX	VSS	2 Analog VSS pins for TXD driver
34	VSSRX	VSS	1 Analog VSS pin for 10BASE-T Receivers

PIN DESCRIPTIONS

10BASE-T Signal Pins

TXD0 \pm

10BASE-T Transmit Data Port 0

Output

TXD0 \pm are the 10BASE-T differential data drivers for port 0.

RXD0 \pm

10BASE-T Receive Data Port 0

Input

RXD0 \pm are the 10BASE-T differential data receivers for port 0.

TXD1 \pm

10BASE-T Transmit Data Port 1

Output

TXD1 \pm are the 10BASE-T differential data drivers for port 1.

RXD \pm

10BASE-T Receive Data Port 1

Input

RXD1 \pm are the 10BASE-T differential data receivers for port 1.

TXD2 \pm

10BASE-T Transmit Data Port 2

Output

TXD2 \pm are the 10BASE-T differential data drivers for port 2.

RXD2 \pm

10BASE-T Receive Data Port 2

Input

RXD2 \pm are the 10BASE-T differential data receivers for port 2.

TXD3 \pm

10BASE-T Transmit Data Port 3

Output

TXD3 \pm are the 10BASE-T differential data drivers for port 3.

RXD3±**10BASE-T Receive Data Port 3
Input**

RXD3± are the 10BASE-T differential data receivers for port 3.

AUI Signal Pins**DO±****AUI Data Out
Output**

When Port 0 is configured for AUI, DO± are the AUI differential data out drivers. Data is transmitted with Manchester encoded signaling compliant with IEEE 802.3 standards.

DI±**AUI Data In
Input**

When Port 0 is configured for AUI (Control Register Reg 18 bit 2), DI± are the AUI differential data in receivers. Data is indicated by Manchester encoded signaling compliant with IEEE 802.3 standards.

PCI/CI+**Pseudo-AUI Collision, AUI Collision Int (-)
Input/Input**

When Interrupt Enable is true (Control Register Reg 18 bit 5) and port 0 is configured for AUI (Control Register Reg 18 bit 2), this pin is configured as PCI. PCI is a single-ended pseudo-AUI collision in signal. Collision is indicated by a 10 MHz pattern.

When Interrupt Enable is false (Control Register Reg 18 bit 5) and port 0 is configured for AUI (Control Register Reg 18 bit 2), this pin is configured as CI+. CI± are the AUI differential collision in signals. Collision is indicated by a 10 MHz pattern compliant with IEEE 802.3 standards.

QINT-/CI-**QuEST Interrupt, AUI Collision Int (-)
Output/Input**

When Interrupt Enable is true (Control Register Reg. 18 bit 5), this pin is configured as QINT. QINT is an active-low signal which indicates that one of the following conditions has occurred: Link Status Change, Duplex Mode Change, Auto-Negotiation Change, MAU Error. Interrupt status flags and enables for individual conditions are reported in the Interrupt Status and Enable Register (Reg 16).

When Interrupt Enable is false (Control Register Reg 18 bit 5) and port 0 is configured for AUI (Control Register Reg 18 bit 2), this pin is configured as CI-. CI± are the AUI differential collision in signals. Collision is indicated by a 10-MHz pattern compliant with IEEE 802.3 standards.

QuASI Interface**QTX_EN****Multiplexed Transmit Enable
Input**

QTX_EN indicates to QuEST that valid transmit data is on QTX_DATA. QTX_EN for all 4 ports is time-division multiplexed onto this signal and is sampled with respect to SCLK. The channel's slot is synchronized to the rising edge of Q \overline RST/STRB.

QTX_DATA**Multiplexed Transmit Data
Input**

QTX_DATA indicates serial NRZ transmit data. QTX_DATA for all 4 ports is time-division multiplexed onto this signal and is sampled with respect to SCLK. The channel's slot is synchronized to the rising edge of Q \overline RST/STRB.

QRX_CRS**Multiplexed Receive Carrier Sense
Output**

QRX_CRS indicates receive or transmit activity on the network. QRX_CRS for all 4 ports is time-division multiplexed onto this signal and is sampled with respect to SCLK. The channel's slot is synchronized to the rising edge of Q \overline RST/STRB.

QRX_VALID**Multiplexed Receive Data Valid
Output**

QRX_VALID indicates that valid receive data is on QRX_DATA. QRX_VALID for all 4 ports is time-division multiplexed onto this signal and is sampled with respect to SCLK. The channel's slot is synchronized to the rising edge of Q \overline RST/STRB. At the rising edge of reset, QRX_VALID is sampled to determine PHYAD 3.

QRX_DATA**Multiplexed Receive Data
Output**

QRX_DATA indicates serial NRZ receive data. QRX_DATA for all 4 ports is time-division multiplexed onto this signal and is sampled with respect to SCLK. The channel's slot is synchronized to the rising edge of Q \overline RST/STRB. At the rising edge of reset, QRX_DATA is sampled to determine PHYAD 4.

QCLSN**Multiplexed Collision
Output**

QCLSN indicates a collision condition on the network. QCLSN for all 4 ports is time-division multiplexed onto this signal and is sampled with respect to SCLK. The channel's slot is synchronized to the rising edge of Q \overline RST/STRB. At the rising edge of reset, QCLSN is sampled to determine PHYAD 2.

Management Interface

MDC

Management Data Clock Input

MDC provides the timing reference for data on the MDIO pin. The Management Interface provides read and write access to QuEST registers, similar to the MII management interface of the IEEE 802.3u standard.

MDIO

Management Data I/O Input/Output

MDIO is a bidirectional data signal between QuEST and a management entity. MDIO timing is referenced to MDC. The Management Interface provides read and write access to QuEST registers, similar to the MII management interface of the IEEE 802.3u standard.

Miscellaneous Pins

SCLK

System Clock Input

SCLK is a 40-MHz (100 ppm) clock used for timing the 10BASE-T ports, the (optional) AUI port, the QuASI interface and core logic.

REXT

External Resistor Input

REXT should be pulled to analog VDD via a 13 k Ω (1% tolerance) external resistor. This signal is used to determine the 10BASE-T transmit current reference.

QRST/STRB

QuEST Reset and Channel 0 Strobe Input

QRST/STRB is an active-low signal that will reset QuEST if asserted for at least 1 μ s. QRST/STRB also forces the channel slots of the QuASI interface to be continuous aligned if strobed for a single clock period.

Power Pins

VDD

Digital Power Power

There is a single power supply pin that is used for internal digital circuitry. The VDD pin must be connected to a +5 V supply.

VSS

Digital Ground Power

There is a single ground pin that is used for internal digital circuitry. The VSS pin must be connected to ground.

VDDIO

Digital I/O Power Power

There is a single power supply pin that is used for digital I/O pins. The VDDIO pin can be connected to either a +5 V or a +3.3 V supply.

VSSIO

Digital I/O Ground Power

There is a single ground pin that is used for digital I/O pins. The VSSIO pin must be connected to ground.

VDDTX

Analog 10BASE-T Power Power

There are three power supply pins that are used for analog 10BASE-T transmit pins. The VDDTX pins must be connected to a +5 V supply.

VSSTX

Analog 10BASE-T Ground Power

There are two ground pins that are used for analog 10BASE-T transmit pins. The VSSTX pins must be connected to ground.

VSSRX

Analog 10BASE-T Ground Power

There is a single ground pin that is used for analog 10BASE-T receive pins. The VSSRX pin must be connected to ground.

VSSAUI

Analog I/O Ground Power

There is a single ground pin that is used for analog AUI circuitry. The VSSAUI pin must be connected to ground.

FUNCTIONAL DESCRIPTION

Overview

The QuEST device is a highly integrated physical layer solution for twisted pair 10-Mbps Ethernet applications. There are three main sets of interfaces to the QuEST. On the network side, there are the 10BASE-T transmit and receive interfaces and one Attachment Unit Interface (AUI). On the system side, there are the QuASI Interface and the Management Interface.

The QuEST device supports four independent ports, each consisting of a 10BASE-T transceiver with on-chip filtering and a Manchester encode/decode unit. The QuEST device incorporates transmit drivers which shape the Manchester waveform and facilitate filterless operation.

The QuEST device provides the option of implementing an AUI suitable for coaxial and fiber MAUs. When the AUI is used, 10BASE-T port 0 is disabled. Ports 1, 2, and 3 remain for 10BASE-T use.

Each 10BASE-T channel is composed of these main circuits: 10BASE-T driver, 10BASE-T receiver, Link Integrity with Auto-Negotiation, Manchester Encoding, Manchester Decoding, and Elasticity FIFO. Shared circuits are the following: the QuASI Interface and the Management Interface with Configuration and Status Registers.

The QuEST device supports Auto-Negotiation as defined by the IEEE 802.3u standard. If the two pieces of networking equipment at each end of a physical link are both capable of Auto-Negotiation, they can exchange information about their respective capabilities and potentially agree to move to a different mode of operation. In the case of the QuEST device, the primary capability it can advertise is full-duplex operation, offering the potential of a 20-Mbps link instead of 10 Mbps. The QuEST device also supports "Next Page," offering the flexibility to add new features in the future.

The QuASI is a unique feature of the QuEST device. This serial interface multiplexes the data for all four serial channels onto one set of pins similar to AMD's General Purpose Serial Interface (GPSI). This interface runs at 40 MHz, providing a data rate for these pins four times faster than a standard 10-Mbps serial interface. This approach reduces the pin count and size of the QuEST device, as well as substantially reducing the number of pins needed to interface the QuEST device to the switching device.

The QuEST device has a 2-pin Management Interface, controlled by the system switch, which allows the QuEST device to be polled for status information. This interface supports the MII protocols specified in the IEEE 802.3u standard. Of the two pins, MDC is the management clock and MDIO is the bidirectional data and control signal.

To further optimize operation, the QuEST device has been designed so that an interrupt mode can be selected to reduce delay associated with polling the status registers.

The QuEST device is designed to easily and reliably interface to systems using either 3.3 V or 5 V supplies. This is accomplished by having a separate power supply pin, VDDIO, which can be connected to either a 3.3 V or a 5 V supply. The digital interface pins of the QuASI interface and the Management Interface are the only pins affected by the choice of supply.

10BASE-T Interface

The 10BASE-T interface section is composed of several circuits and logic blocks: 10BASE-T transmitter, 10BASE-T receiver, Collision, and Link Integrity with Auto-Negotiation. The QuEST device contains four identical 10BASE-T circuits.

10BASE-T Transmitter

The 10BASE-T transmitter is composed of several important sub circuits. The major function of the 10BASE-T driver is to impart an analog waveform in Manchester format which adheres to the IEEE 802.3i 10BASE-T specification. The transmitter consists of a 10BASE-T driver with on-chip filtering, Jabber timer, and provisions to generate Link pulses for Link Integrity and Auto-Negotiation functions.

Driver

The QuEST device incorporates a waveform driver, eliminating the need for off-chip filters. The driver circuit requires a 5 V supply. The 10BASE-T driver circuit shapes the analog waveform in a pre-distorted manner, emulating the effect of an external filter. The transmitter requires a 110- Ω (1% tolerance) resistor connected in parallel with the TXD pins. The waveform generated is compliant with the IEEE 802.3i Ethernet specification. During idle periods, 10BASE-T driver pins float to a high impedance state at mid-supply voltage. During idle periods, power consumption is minimized.

Jabber Condition

The 10BASE-T transmit circuit includes a Jabber timer which prevents the transmission of an excessively long frame. The Jabber condition is invoked when a frame longer than 30 ms is transmitted from the QuASI interface to the 10BASE-T driver. When the Jabber condition is invoked, the transmit enable must be held inactive for approximately 0.5 seconds to allow the Jabber condition to reset. The Jabber timer provides a simple method to protect the network from excessively long frames. When the Jabber condition is invoked, the Collision indication will be asserted if the Link Integrity state machine is in the pass state.

10BASE-T Receiver

The 10BASE-T interface section includes a compliant 10BASE-T receiver which incorporates a low pass filter eliminating the requirement for off-chip filters. The receiver circuit employs squelch circuits programmable to a standard distance of 100 meters and an extended distance mode for distances greater than 100 meters. The squelch circuit requires that the differential receive data on RXD± exceed the squelch levels on both negative and positive pulses and occur in a consecutive negative, positive, negative sequence.

There are restrictions on the frequency and pulse width duration. If all conditions are met, the receiver will transition to the unsquelch state, which indicates that a 10BASE-T carrier is detected. If either the voltage levels drop below a defined minimum or the frequency of the incoming waveform drops below a set minimum, the squelch circuit will indicate that the carrier is no longer present. When the carrier is dropped, the squelch circuit will return to the squelched state.

In order for an incoming Ethernet frame to be received on the 10BASE-T receive pair, the frame must first pass the receive squelch levels. The received Manchester data is then forwarded to the Manchester decoder. The Manchester decoder extracts the clock and receive data from the Manchester data stream and forwards the data to the elasticity FIFO. The sole purpose of the elasticity FIFO is to rate match the receive data to the synchronous system clock, SCLK. The data which is output from the elasticity FIFOs is combined in the serial multiplexer logic and output in a serially multiplexed format through the QuASI Interface.

In addition to detecting a 10BASE-T carrier, the receiver detects valid link pulses. Valid link pulses must pass the squelch level amplitude, but must not be too short or too long in duration. If link pulses are detected, this information is passed to the Link Integrity and Auto-Negotiation logic.

Once in the unsquelched state, the receiver amplifies the differential signal to full CMOS levels for Manchester clock and data extraction.

Differential Receiver

The differential receiver accepts data in differential format. The receiver has internal filtering and does not require external filters. The RXD receive pair require a 100-Ω (1% tolerance) termination resistor across their inputs. The RXD inputs are internally biased to approximately 3 V. When properly terminated, the RXD ports will satisfy the electrical requirements for 10BASE-T receivers in the IEEE 802.3i standard.

Receive Polarity Correction

The receive function includes the ability to invert the polarity of the signals appearing at the RXD± pair if the

polarity of the received signal is reversed, (e.g., wiring error in cable). The polarity correction can be disabled by setting Bit 3 of the Control Register (Reg 18). The polarity detection function is activated following Reset or Link Fail and will reverse the receive polarity based on both link pulses and subsequent received frames with a valid End of Transmit Delimiter (ETD).

When in the Link Fail State, the QuEST device will recognize link test pulses of either positive or negative polarity. Exit from the Link Fail state is caused by the reception of five consecutive link pulses of identical polarity. The polarity of both the link pulses and the ETD character of valid frames are used to determine the initial receive polarity. Once two consecutive frames are received with the same polarity, the polarity function is locked until a reset or link failure occurs.

Extended Distance

The receive squelch thresholds can be programmed to 60 percent of the normal level to allow reception of valid 10BASE-T receive frames over distances longer than 100 meters of cable. Normal operation (default) of the QuEST device is set to standard 10BASE-T thresholds. Extended distance mode is programmed by setting Control Register (Reg. 18, bit 1).

Collision

When a valid receive frame is detected by unsquelching the input receiver and there is simultaneous activity of the TXD± pairs, a collision is detected and indicated at the QuASI interface by assertion of the QCLSN signal during the appropriate channel slot time.

The QCLSN signal can be asserted for two other conditions. If the SQE_TEST disable bit, Control Register (Reg. 18, bit 0) is de-asserted, the QCLSN signal will be asserted just after transmission of a valid frame during the SQE window. If the 10BASE-T transmitter is in the Jabber state, the QCLSN signal will be asserted during the channel slot time if the QTX_EN enable signal is asserted for that channel.

When the QuEST device is in full duplex mode, no collision events are indicated.

Link Integrity with Auto-Negotiation

General

The QuEST device can be configured to support either the standard 10BASE-T link integrity algorithm as specified in the IEEE 802.3i Standard or the Auto-Negotiation algorithm as specified in the IEEE 802.3u standard. Auto-Negotiation allows the device to automatically negotiate to full duplex operation if the remote device at the end of the cable supports full duplex operation. Remote Fault and Next Page are also supported. If the remote device does not support Auto-Negotiation, the algorithm defaults to the standard 10BASE-T algorithm.

The QuEST can be manually configured to support either half-duplex or full-duplex operation. The QuEST device can operate with any remote 10BASE-T standard device or like devices that support the Auto-Negotiation algorithm, including 10/100 Mbps devices.

10BASE-T Algorithm

The QuEST device implements the standard 10BASE-T algorithm as defined in the IEEE 802.3 specification. The 10BASE-T algorithm uses Normal Link Pulses (NLP) to establish link integrity. In the standard 10BASE-T algorithm, link pulses are transmitted approximately every 16 ms \pm 8 ms in the absence of transmitted data. Upon reception of five consecutive link pulses with constant polarity within the specified minimum and maximum times, the QuEST device will detect the presence of a valid link. Reception of a valid receive frame will transition the QuEST device to the link pass state in the absence of link pulses.

Auto-Negotiation Algorithm

The Auto-Negotiation function determines the abilities of two networking devices at each end of a physical link, if both devices are capable of Auto-Negotiation. After exchanging abilities, the QuEST device and remote link partner device acknowledge each other and choose which advertised abilities to support. The Auto-Negotiation function of the QuEST chip facilitates an ordered resolution between exchanged abilities. This exchange allows the devices at either end of the link to take maximum advantage of their respective shared abilities. In the case of the QuEST device, the primary capability it can advertise is full-duplex operation, offering the potential of a 20-Mbps link instead of 10 Mbps in half-duplex mode.

The QuEST device implements the transmit and receive Auto-Negotiation algorithm as defined in IEEE 802.3u standard. The Auto-Negotiation algorithm uses a burst of link pulses called Fast Link Pulses (FLPs). The burst of link pulses are spaced between 55 and 140 μ s so as to be ignored by the standard 10BASE-T algorithm. The FLP burst conveys information about the abilities of the sending device. The receiver can accept and decode an FLP burst to learn the abilities of the sending device. The link pulses transmitted conform to the standard 10BASE-T template.

The QuEST device uses the Auto-Negotiation algorithm to advertise either full- or half-duplex capabilities. The QuEST device can be programmed to force either half- or full-duplex, or to auto-negotiate between half- and full-duplex operation.

The Auto-Negotiation algorithm is initiated when one of the following events occurs: Reset, Auto-Negotiation reset, transition to link fail state, or the Auto-Negotiation enable bit is set. After the Auto-Negotiation algorithm is completed, the device will be in either a

half- or full-duplex state. The result of the Auto-Negotiation can be read from the status register for the port of interest. After conclusion of the Auto-Negotiation process, the QuEST device reverts back to the standard 10BASE-T link integrity algorithm (i.e., transmission of standard link pulses).

The QuEST device also supports "Next Page," offering the flexibility to add new features in the future.

Manchester Encoder

The QuEST device provides separate Manchester encode circuits per transmit channel. The QuEST device converts the Non-Return to Zero (NRZ) data received after separating the data from the QuASI interface. The Manchester encoding process complements the first half of the data bit. During the second half of the data bit, the true value is sent. Manchester encoding always guarantees a transition at the Bit Cell Center (BCC). Transmission and encoding occur only when the QTX_EN line is asserted during the appropriate time slot.

Manchester Decoder

The QuEST device provides separate Manchester decode circuits per receive channel. The Manchester Decoder allows for extracting the clock and NRZ data from the received Manchester data stream. After the appropriate receive squelch paths have opened, the Manchester decoder locks onto an incoming frame within two bit times. The Manchester decoder incorporates a fast locking acquisition circuit during the beginning of preamble. The Manchester decode circuit discards approximately 3 bits of data during the data acquisition phase. The maximum jitter tolerated is 13.5 ns on the 10BASE-T ports and 18 ns on the AUI port. Manchester data which is decoded by the unit is sent to the elasticity FIFO for rate decoupling.

Elasticity FIFO

The QuEST device incorporates a 10-bit elasticity FIFO. The purpose of the elasticity FIFO is to rate match the frequency of the incoming receive data to the rate of the System Clock (SCLK).

Attachment Unit Interface (AUI)

General

The QuEST device provides an optional AUI that can be allocated to port 0 of the four ports. The AUI allows a non-10BASE-T MAU (i.e., 10BASE-2, 10BASE-5, or 10BASE-FL transceiver) to connect to port 0. When the AUI interface is selected for port 0, the 10BASE-T circuit on that interface is disabled. If the 10BASE-T circuit is disabled, the 10BASE-T circuit will terminate the transmission and reception of link pulses as well as frame data. The AUI port will use the Manchester encoder/decoder circuitry of that port.

Either five or six signal pins are used for the AUI function: DO_{\pm} , DI_{\pm} , $PCI/CI+$; and, if Interrupt is disabled, $QINT/CI-$.

AUI Transmitter

The AUI circuit provides a differential transmit circuit which operates at Pseudo Emitter Coupled Logic (PECL) levels. The DO_{\pm} circuit provides an internal termination resistor of 80.4Ω . When the AUI port is disabled, the DO driver circuit will idle at zero differential voltage with an impedance of 80.4Ω .

AUI Receiver

The AUI receive circuit consists of a PECL receiver circuit. It is recommended that DI_{\pm} inputs be terminated differentially with two 40.2Ω resistors with the middle node connected to a 0.1 to $0.01 \mu\text{F}$ by-pass capacitor to analog ground.

In order for the AUI to unsquelch, the differential receive data must exceed requirements for both negative amplitude and time duration. Once unsquelched, the receive data is sent to the Manchester decode unit for clock recovery and data extraction.

Collision

The AUI collision front-end circuit is similar to the AUI receiver circuit. The CI_{\pm} inputs should be differentially terminated with two 40.2Ω resistors with the middle node of the resistors connected to a 0.1 to $0.01 \mu\text{F}$ by-pass capacitor to analog ground. In order for a collision to be detected, the differential receive data must pass negative amplitude and time duration. Once the collision circuit is unsquelched, the collision is indicated on the $QCLSN$ signal during the port 0 multiplexed time slot.

The AUI port can be configured as a full-duplex port for 10BASE-FL application. If configured as a full-duplex port, the collision indication will not be signaled on the QuASI Interface.

When the AUI and Interrupt modes are enabled, the collision front end is changed to a single-ended input with the same threshold requirements as above. The positive signal of the collision differential pair is used as the collision input. The $CI-$ signal is isolated and biased to an idle level. This frees up the external pin to be switched in with the interrupt driver circuitry and to function as an open drain interrupt output.

QuASI Interface

The QuASI interface provides four 10-Mbps Ethernet channels that are serially multiplexed to a set of shared pins. The data rate of these pins is four times faster than a standard 10-Mbps serial interface.

The QuASI interface is composed of a clock, $\overline{QRST/STRB}$, and six signal pins. The purpose of this interface is to allow time division multiplexing of the digital serial

data. The clock input, $SCLK$, is nominally a 40-MHz signal. This clock input should have a frequency tolerance to 100 ppm.

The QuEST internally divides the 40-MHz $SCLK$ input into four clock phases or slots. (Refer to QuASI interface diagram in the *Switching Characteristics* section.) When the $\overline{QRST/STRB}$ signal is de-asserted, the internal divide circuit is locked into a repeatable sequence. The first rising edge of the $SCLK$ input after the de-assertion of $\overline{QRST/STRB}$ results in the input signals, QTX_EN and QTX_DATA , being locked to channel 0. To transmit data for the first channel 0 slot, the transmit data and transmit enable signal must meet the setup and hold times associated with the first rising edge of $SCLK$ after $\overline{QRST/STRB}$ is driven inactive. The repetitive channel order for transmitting data is channel 0 to channel 3.

The second rising edge of the $SCLK$ input after reset de-assertion results in the output signals, QRX_DATA , QRX_VALID , QRX_CRS , and $QCLSN$, being locked to channel 3. The receive data for the first channel 3 slot is valid during the second rising edge of $SCLK$. Successive clock edges increment the channel slot number in a repetitive fashion. The repetitive channel order is channel 0 to channel 3. Consequently, all signal pins are synchronous to the clock pin, $SCLK$.

The \overline{STRB} (strobe) function of the $\overline{QRST/STRB}$ input pin allows the option to strobe the input for a single clock during normal operation to ensure alignment of the QuASI interface to channel 0. The use of the strobe option minimizes possibility of channel misalignments.

In order to transmit a packet, QTX_EN needs to be asserted during the correct channel or slot number. If QTX_EN is asserted, then the NRZ QTX_DATA is interpreted and sent to the Manchester encode unit for transmission to the 10BASE-T or AUI interface. QTX_EN and QTX_DATA should contain the preamble and data portions of the frame to be sent. The End of Transmission Delimiter will be added by the encode unit. As an example, if channel 0 is the only transmit channel active, then QTX_EN signal will only be asserted during the slot time of channel 0. As part of the transmission process, the QTX_DATA data signal is looped back to the QRX_CRS and QRX_VALID signals when in half-duplex mode and the Link Pass State.

When data is received from the network, the data is first placed in the Elasticity FIFO. There are three signals associated with the receive stream: QRX_CRS , QRX_VALID , and QRX_DATA . When receive data triggers the squelch paths of either the 10BASE-T or AUI receiver, the QRX_CRS signal is asserted at the earliest possible time. Receive Carrier Sense (QRX_CRS) signal is used for signaling real-time network activity to the external device connected to the QuEST device.

QRX_CRS signal is primarily useful for calibrating network timers in the external MAC or repeater device.

Data which is held in the elasticity FIFO will be delayed. When the QRX_VALID (Receive Data Valid) is asserted in the appropriate slot, the QRX_DATA is valid. QRX_VALID is used as a framing signal to indicate when the QRX_DATA is valid. QRX_VALID and QRX_DATA will lag QRX_CRS by up to four bit times (400 ns) in the beginning of the frame and up to 8 bits by the end of the frame. The reason that QRX_VALID lags QRX_CRS signal by a variable amount of time is due to the inherent rate mismatch between the received data and network clocks.

The QCLSN signal is asserted whenever a network collision is detected. QCLSN is time multiplexed like the other receive signals. QCLSN has a specific meaning within the specified channel or slot number. Collision indication is asserted in its appropriate time slot whenever a network collision is detected. The QCLSN pin may be optionally asserted if the SQE_TEST disable

bit, Control Register (Reg. 18, bit 0), is in a cleared state after transmission of a packet.

In summary, the QuASI Interface is synchronous to the clock input, SCLK. A reset signal, QRST/STRB, is provided which serves two purposes, hardware reset and a means for channel slot synchronization. There are six additional signal pins that communicate the serial data to and from the QuEST device.

Management Interface

The QuEST device incorporates a two-wire Management Interface in conformance with the MII Management Interface of the IEEE 802.3u Standard. The interface includes a management clock, MDC, and a serial data I/O pin, MDIO. The Management Interface clock can operate as high as 20 MHz; there is no lower frequency limit. The MDIO signal serves as both control and data. The first part of the command is composed of control information, while the second half is composed of data. The management frame format is indicated below.

Table 1. Management Frame Fields

	ST	OP	PHYAD	REGAD	TA	DATA	IDLE
READ	01	10	A ₄ AAAA ₀	R ₄ RRRR ₀	Z0	D ₁₅ DDDDDDDDDDDDDDDD ₀	Z
WRITE	01	01	A ₄ AAAA ₀	R ₄ RRRR ₀	10	D ₁₅ DDDDDDDDDDDDDDDD ₀	Z

The Management Frame

The management frame begins with the Start of Frame (ST) delimiter indicated by a <01> pattern. After the ST pattern, the Operation Code (OP) indicates either a read or a write, followed by the PHYAD and REGAD fields. The specific address is identified by the five bits of the PHY address (PHYAD); the specific register is identified by the five bits of the Register Address (REGAD). The Turn Around (TA) field follows and provides a two-cycle delay for redirecting the MDIO bus during read commands, to avoid signal contention. The management frame includes the 16-bit wide data field and terminates with an idle state indication.

PHY Addressing

PHYAD is the unique address of any PHY connected to this Serial Management Interface. Each QuEST supports four PHYs, and up to eight QuEST devices can be connected to the Management Interface. A total of 32 PHYs can be managed. (Refer to Table 2.)

The internal QuEST address is formed through external means. During reset, the QRX_DATA, QRX_VALID, QRX_CRS, and QCLSN signals of the QuEST device are in tristate. At the rising edge of reset, the QuEST device latches signal pins QRX_VALID, QRX_CRS, and QCLSN to form the internal address which the QuEST device will use to match against. The QuEST

device provides internal pull-down resistors of approximately 100 kΩ.

Pull-up resistors of 10 kΩ in value can be placed on the QRX_DATA, QRX_VALID, and QCLSN signals to define the internally latched address. The internal latch address is shown below. The internally latched address must be unique among QuEST devices shared by a single Management Interface. To form the QuEST address “000,” no resistors need to be connected. To form the QuEST address “101”, external pull-up resistors are required to be added to the QRX_DATA and QCLSN signals, and so forth.

A specific PHY address (PHYAD) is formed with five bits. The upper three bits of the PHYAD, A₄, A₃, and A₂, are matched to an internal QuEST device address which acts as a chip selection function. Setting each of these three bits to 0 or 1 in combination allows specific designation of up to eight QuEST devices. The lower two bits of the PHYAD designate the channel number of the designated QuEST device.

Table 2. QuEST Device Address Designations

PHYAD Bits			Signals with Pull up Resistors
A4	A3	A2	
0	0	0	no signals
0	0	1	QCLSN
0	1	0	QRX_VALID
0	1	1	QRX_VALID, QCLSN
1	0	0	QRX_DATA
1	0	1	QRX_DATA, QCLSN
1	1	0	QRX_DATA, QRX_VALID
1	1	1	QRX_DATA, QRX_VALID, QCLSN

Table 3. Channel Address Designations

PHYAD Bit		Channel Number
A1	A0	
0	0	0
0	1	1
1	0	2
1	1	3

Interrupt Function

The Interrupt function indicates when there is a change in the Link Status, Duplex Mode, Auto-Negotiation status, MAU Error status, or any combination thereof for any port. The Interrupt Register (Register 16) contains the interrupt status and interrupt enable bits. The status is always updated whether the interrupt enable bits are set or not. However, if the interrupt enable bits are set active, the logical OR of the selected bits will drive the QINT open drain output pin.

When an interrupt occurs, the system will need to poll the interrupt register to determine the source of the interrupt and to clear the status bits. The individual registers can be read to determine the exact nature of the change in status. Individual bits clear on read (COR) except for the Jabber error, which is a Self-Clearing (SC) bit when the QuEST device exits the Jabber state.

3.3 Volt Operation

The QuEST device is designed to easily and reliably interface to systems with 3.3 V or 5 V power supplies. This is accomplished by having a separate power supply pin, VDDIO, which can be connected to either a 3.3 V or 5 V supply. The only pins affected by the choice of supply are: QRX_DATA, QRX_VALID, QRX_CRIS, QCLSN, and MDIO.

The data sheet specification for the QuEST device is for TTL input and output levels. The QuEST device meets these specifications, regardless of which supply voltage is used. The difference made by using a 3.3 V supply is that the MAXIMUM output voltage on the pins listed above is guaranteed by design not to exceed 3.3 V.

REGISTER DESCRIPTION

The QuEST device supports nine physical registers per port plus four registers which are globally shared among all four ports. In summary, there are 40 registers available.

Table 4. Register and Port Matrix

REGAD	Register Name	PHYAD [0:1] /Port			
		00	01	10	11
0	Auto Negotiation Control	0	1	2	3
1	Auto Negotiation Status	0	1	2	3
2-3	Device ID	Shared			
4	Auto Negotiation Advertisement	0	1	2	3
5	Auto Negotiation Link Partner	0	1	2	3
6	Auto Negotiation Expansion	0	1	2	3
7	Auto Negotiation Next Page	0	1	2	3
8-15	Unused	Unused			
16	Status Change Interrupt	Shared			
17	Summary Status	Shared			
18	Control	0	1	2	3
19	Status	0	1	2	3
20	Error Mask	0	1	2	3

Shared Registers

Four registers are globally shared among all four ports: Registers 2 and 3 designate the Device ID, Register 16 is Interrupt Enable and Status, and Register 17 is Summary Status. When accessing the shared registers, the lower two bits of the PHYAD address (bits A1 and A0) are ignored.

Table 5. Shared Registers

REGAD	Register Name
2-3	Device ID
16	Interrupt Enable and Status
17	Summary Status

Port Registers

Nine physical registers in the QuEST device are allocated per port. Six of the port registers relate to Auto-Negotiation. The remaining port registers are used for control.

Registers 0, 1, 4-7, and 18-20 require an exact match to specify the port being addressed. A particular register is addressed by sending the serial management frame with the target address of the designated port. The lower two bits of the PHYAD (bits A1 and A0) specify which port is selected.

Table 6. Port Registers

REGAD	Register Name
0	Auto Negotiation Control
1	Auto Negotiation Status
4	Auto Negotiation Address
5	Auto Negotiation Link Partner
6	Auto Negotiation Expansion
7	Auto Negotiation Next Page
18	Control
19	Status
20	Error Mask

Non-Implemented Registers

Non-implemented registers should neither be written to or read. Reserved register bits within defined registers should be written with zeros. **Reserved register bits may return undefined data and should be masked by software.**

Auto-Negotiation Control Register (Reg 0)

The Auto-Negotiation Control Register (Reg 0) contains Read/Write (R/W), Read/Only (R/O), and Self-Clearing (SC) bits. This register is duplicated for each port.

Table 7. Auto-Negotiation Control Register (Reg 0)

Bit(s)	Name	Description	Read/Write	Default/Reset
15	SRESET	1 = Resets the Auto Negotiation Control and Status registers to their default state; 0 = Has no effect. After reset is completed (approximately 10 μ s), SRESET is cleared.	R/W, SC	0
14	Loopback	1 = Port will loop back the QTX_DATA to the QRX_DATA. Transmit data will not be transmitted and receive data from the network will be ignored. 0 = The port will receive and transmit normally.	R/W	0
13	Reserved	Written and read as zero.	R/O	0
12	ANEG_EN	1 = Auto-Negotiation enabled. 0 = Auto-Negotiation disabled.	R/W	1
11	PWR_DN	1 = 10BASE-T port Auto-Negotiation is reset. The Auto-Negotiation process and Link Status State Machine will terminate. Link Test Pulses will terminate. 0 = 10BASE-T port resumes normal operation.	R/W	0
10	Reserved	Written and read as zero.	R/O	0
9	Restart ANEG	1 = Auto-Negotiation restarts. The bit will be cleared when the Auto-Negotiation process completes. 0 = Has no effect.	R/W, SC	0

8	Duplex_Mode	1 = The port can be forced into full duplex operation when both the Duplex_Mode set and the ANEG_EN bit clear. If the ANEG_EN bit is set, this bit is ignored. When the Duplex_Mode is modified, the port status will not be modified unless the ANEG_EN bit is cleared. 0 = Port is forced to half-duplex mode when ANEG_EN bit is cleared. If ANEG_EN bit is set, this bit is ignored.	R/W	0
7	Collision Test	1 = Collision indication will occur on the channel after the transmit enable bit (QTX_EN) is asserted. 0 = Port operation is normal.	R/W	0
6:0	Reserved	Written and read as zero.	R/O	0

Auto-Negotiation Status Register (Reg 1)

The Auto-Negotiation Status Register (Reg 1) contains

Read/Only (R/O) bits or Clear on Read (COR) bits. This register is duplicated for each port.

Table 8. Auto-Negotiation Status Register (Reg 1)

Bit(s)	Name	Description	Read/Write	Default/Reset
15:13	Reserved	Written and read as zero.	R/O	0
12	Full Duplex	1 = Capable of operation in full duplex mode; 0 = Not able to perform full duplex mode.	R/O	1
11	Half Duplex	1 = Capable of operation in half duplex mode; 0 = Not able to perform half duplex mode.	R/O	1
10:7	Reserved	Written and read as zero.	R/O	0
6	Preamble Suppress	1 = Management Interface operates with or without preamble suppression; 0 = Not applicable: Management Interface will operate with or without preamble suppression.	R/O	1
5	Auto-Negotiation Complete	1 = Auto-Negotiation is complete; 0 = Auto-Negotiation is not complete.	R/O	0
4	Remote Fault	1 = Remote fault detected from link partner; 0 = No remote fault detected.	R/O, COR	0
3	Auto-Negotiation Ability	1 = Capable of Auto-Negotiation; 0 = Not available	R/O	1
2	Link Status	1 = Link is up; 0 = Link is down.	R/O	0
1	Jabber Detect	1 = Jabber Condition detected; 0 = Jabber Condition not detected.	R/O	0
0	Extended Register Capability	1 = Extended Register Capability; 0 = Not applicable.	R/O	1

Device ID Registers (Reg 2-3)

Device ID Registers (Reg 2-3) contain Read/Only (R/O) bits. Registers 2 and 3 designate a unique Device ID: the manufacturer ID is designated by Reg 2 bits

15:0 and Reg 3 bits 15:10; the model number is designated by Reg 3 bits 9:4; the Revision Number is designated by Reg 3 bits 3:0. This register is not duplicated for each port.

Table 9. Register 2

Bit(s)	Name	Description	Read/Write	Default/Reset (binary)	Default/Reset (Hex)
15:0	PHY_ID[31:16]	Bits 3-18 of the IEEE Organizationally Unique Identifier.	R/O	0000 0000 0000 0000	0000

Table 10. Register 3

Bit(s)	Name	Description	Read/Write	Default/Reset (binary)	Default/Reset (Hex)
15:10	PHY_ID[15:10]	Bits 19-24 of the IEEE Organizationally Unique Identifier.	R/O	01 1010	1A
9:4	PHY_ID[9:4]	QuEST Model Number	R/O	01 1111	1F
3:0	PHY_ID[3:0]	Revision Number	R/O	0000	0

Auto-Negotiation Advertisement Register (Reg 4)

The Auto-Negotiation Advertisement Register (Reg 4) contains Read/Write (R/W) or Read/Only (R/O) bits. This register contains the advertised ability of the QuEST device. This register is duplicated on a per port

basis. The purpose of this register is to advertise the technology ability to the link partner device. When this register is modified, Restart Auto-Negotiation (Reg 0, bit 9) must be set to advertise the change.

Table 11. Auto-Negotiation Advertisement Register (Reg 4)

Bit(s)	Name	Description	Read/Write	Default/Reset
15	Next Page	1 = Next page exchange requested; 0 = Next page exchange not requested.	R/W	0
14	Reserved	Written and read as zero.	R/O	0
13	Remote Fault	1 = Remote fault bit is inserted into the base link code word during the Auto-Negotiation process; 0 = The base link code work will have the bit position for remote fault as cleared.	R/W	0
12:11	Reserved	Written and read as zero.	R/O	0
10:7	Reserved	Written and read as zero.	R/O	0
6	Full Duplex	1 = Full Duplex capability is advertised; 0 = Full Duplex capability is not advertised.	R/W	0
5	Half duplex	1 = Half Duplex capability is advertised; 0 = Half Duplex capability is not advertised	R/W	1
4:0	Selector Field	The QuEST device is an IEEE 802.3 compliant device.	R/O	0x01

Note: When this register is modified, Restart Auto-Negotiation (Reg 0, bit 9) must be set to advertise the change.

Auto-Negotiation Link Partner Ability Register (Reg 5)

The Auto-Negotiation Link Partner Ability Register (Reg 5) describes the advertised ability of the link

partner. The register is Read/Only (R/O). The bits represent the received link code word. This register contains either the base page or the link partner's next pages. This register is duplicated for each port.

Table 12. Base Page Format

Bit(s)	Name	Description	Read/Write	Default/Reset
15	Next Page	1 = Link partner next page requested; 0 = Link partner next page not requested.	R/O	0
14	Acknowledge	1 = Link Partner acknowledged; 0 = Link Partner not acknowledged.	R/O	0
13	Remote Fault	1 = Link Partner has a remote fault; 0 = Link Partner does not have a remote fault.	R/O	0
12:5	Technology Ability	Link Partner technology ability.	R/O	0
4:0	Selector Field	Link partner selector field.	R/O	0

Table 13. Next Page Format

Bit(s)	Name	Description	Read/Write	Default/Reset
15	Next Page	1 = Link partner next page requested; 0 = Link partner next page not requested.	R/O	0
14	Acknowledge	1 = Link Partner acknowledged; 0 = Link Partner not acknowledged.	R/O	0
13	Message Page	1 = Link Partner message page; 0 = Link Partner unformatted next page.	R/O	0
12	Acknowledge 2	1 = Link Partner can comply with the request 0 = Link Partner cannot comply with the request.	R/O	0
11	Toggle	Link partner toggle bit.	R/O	0
10:0	Message Field	Link partner's message code.	R/O	0

Auto-Negotiation Expansion Register (Reg 6)

The Auto-Negotiation Expansion Register (Reg 6) provides additional information which assists in the Auto-

Negotiation process. The Auto-Negotiation Register bits are Read/Only (R/O) or Cleared on Read (COR). This register is duplicated for each port.

Table 14. Auto-Negotiation Expansion Register (Reg 6)

Bit(s)	Name	Description	Read/Write	Default/Reset
15:4	Reserved	Written and read as zero.	R/O	0
3	Link Partner Next Page Able	1 = Link partner is next page able. 0 = Link partner is not next page able.	R/O	0
2	Next Page Able	1 = QuEST device port is next page able. 0 = Not applicable.	R/O	1
1	Page Received	1 = A new page has been received. 0 = A new page has not been received. Cleared on Read.	R/O, COR	0
0	Link Partner Auto-Negotiation Able	1 = Link partner is Auto-Negotiation able. 0 = Link partner is not Auto-Negotiation able.	R/O	0

Auto-Negotiation Next Page Register (Reg 7)

The Auto-Negotiation Next Page Register (Reg 7) contains the next link page link code word to be transmitted. The Auto-Negotiation Next Page Register contains

Read/Write (R/W) or Read/Only (R/O) bits. On power-up the default value of 0x2001 represents a message page with the message code set to null. This register is duplicated for each port.

Table 15. Auto-Negotiation Next Page Register (Reg 7)

Bit(s)	Name	Description	Read/Write	Default/Reset
15	Next Page	1 = QuEST device port next page requested; 0 = QuEST device port next page not requested.	R/W	0
14	Reserved	Written and read as zero.	R/O	0
13	Message Page	1 = QuEST device port message page requested; 0 = QuEST device port unformatted page requested.	R/W	1
12	Acknowledge 2	1 = QuEST device port can comply with the request; 0 = QuEST device port cannot comply with the request.	R/W	0
11	Toggle	QuEST device port toggle bit.	R/O	0
10:0	Message Field	Message code field.	R/W	0x001

Interrupt Status and Enable Register (Reg 16)

Read (COR) bits. This register is shared across all ports.

Interrupt Status and Enable Register (Reg 16) contains Read/Write (R/W), Read/Only (R/O), or Cleared on

Table 16. Interrupt Status and Enable Register (Reg 16)

Bit(s)	Name	Description	Read/Write	Default/Reset
15:13	Reserved	Written and read as zero.	R/O	0
12	Link Status Change Interrupt Enable	1 = Link Status Change Interrupt drives the \overline{QINT} pin; 0 = The Interrupt is masked.	R/W	0
11	Duplex Change Interrupt Enable	1 = Duplex Change Interrupt drives the \overline{QINT} pin; 0 = The Interrupt is masked.	R/W	0
10	Auto-Negotiation Change Interrupt Enable	1 = Auto-Negotiation Change Interrupt drives the \overline{QINT} pin (i.e., new page received); 0 = The Interrupt is masked.	R/W	0
9	MAU Error Interrupt Enable	1 = MAU Error Interrupt drives the \overline{QINT} pin; 0 = The Interrupt is masked.	R/W	0
8	Global Interrupt Enable	1 = Any Interrupt drives the \overline{QINT} pin; 0 = The Interrupt is masked.	R/W	0
7:5	Reserved	Written and read as zero.	R/O	0
4	Link Status Change Interrupt	1 = Link Status changed on one of the 4 ports; 0 = No change in Link Status. Register bit is cleared on Read.	R/O, COR	0
3	Duplex Change Interrupt	1 = Duplex mode changed on one of the 4 ports; 0 = Indicates no change in Duplex mode. Register bit is cleared on Read.	R/O, COR	0
2	Auto-Negotiation Change Interrupt	1 = Auto-Negotiation status has changed on one of the 4 ports; 0 = Indicates no change. Register bit is Cleared on Read.	R/O, COR	0
1	MAU Error Interrupt	1 = A MAU error has occurred on one of the 4 ports; set on any error bit in the Status Register (Reg 19) for any port; 0 = Indicates no MAU errors have occurred. Register bit is cleared on Read.	R/O, COR	0
0	Global Interrupt	1 = Change in status of any of the above interrupts; 0 = No Interrupt condition. Register bit is Cleared on Read.	R/O, COR	0

Summary Status Register (Reg 17)

The Summary Status Register (Reg 17) is a global register accessible to all ports. This register is Read/Only

(R/O). The summary register allocates four bits per each port. Each port conveys: Link Status, Duplex Status, Auto-Negotiation Alert, and 10BASE-T MAU Error.

Table 17. Summary Status Register (Reg 17)

Bit(s)	Name	Description	Read/Write	Default/Reset
15	Link Status Port 3	1 = Link Status of port 3 is up; 0 = Link Status of port 3 is down.	R/O	0
14	Full Duplex Port 3	1 = Port 3 is operating in full duplex mode; 0 = Port 3 is operating in half duplex mode.	R/O	0
13	Auto-Negotiation Alert Port 3	1 = Status of Auto-Negotiation function for port 3 has changed (i.e, new page received); 0 = Auto-Negotiation function for port 3 does not require servicing.	R/O	0
12	MAU Error Port 3	1= 10BASE-T MAU error for port 3 summary; 0= No MAU Error on Port 3.	R/O	0
11	Link Status Port 2	1 = Link Status of port 2 is up; 0 = Link Status of port 2 is down.	R/O	0
10	Full Duplex Port 2	1 = Port 2 is operating in full duplex mode; 0 = Port 2 is operating in half duplex mode.	R/O	0
9	Auto-Negotiation Alert Port 2	1 = Status of Auto-Negotiation function for port 2 has changed (i.e, new page received); 0 = Auto-Negotiation function for port 2 does not require servicing.	R/O	0
8	MAU Error Port 2	1= 10BASE-T MAU error for port 2 summary; 0= No MAU Error on Port 2.	R/O	0
7	Link Status Port 1	1 = Link Status of port 1 is up; 0 = Link Status of port 1 is down.	R/O	0
6	Full Duplex Port 1	1 = Port 1 is operating in full duplex mode; 0 = Port 1 is operating in half duplex mode.	R/O	0
5	Auto-Negotiation Alert Port 1	1 = Status of Auto-Negotiation function for port 1 has changed (i.e, new page received); 0 = Auto-Negotiation function for port 1 does not require servicing.	R/O	0
4	MAU Error Port 1	1= 10BASE-T MAU error for port 1 summary; 0= No MAU Error on Port 1.	R/O	0
3	Link Status Port 0	1 = Link Status of port 0 is up; 0 = Link Status of port 0 is down.	R/O	0
2	Full Duplex Port 0	1 = Port 0 is operating in full duplex mode; 0 = Port 0 is operating in half duplex mode.	R/O	0
1	Auto-Negotiation Alert Port 0	1 = Status of Auto-Negotiation function for port 0 has changed (i.e, new page received); 0 = Auto-Negotiation function for port 0 does not require servicing.	R/O	0
0	MAU Error Port 0	1= 10BASE-T MAU error for port 0 summary; 0= No MAU Error on Port 0.	R/O	0

Control Register (Reg 18)

The Control Register (Reg 18) configures the port in conjunction with the Auto-Negotiation registers. The

Control Register contains Read/Write (R/W) or Read/Only (R/O) bits. This register is duplicated for each port.

Table 18. Control Register (Reg 18)

Bit(s)	Name	Description	Read/Write	Default/Reset
15	Force Link Good Enable	1 = 10BASE-T link integrity state machine is forced to the "link good" state; 0 = Normal operation resumes. For internal test only (when link pulses are absent). Not for general use in 10BASE-T applications.	R/W	0
14:6	Reserved	Written and read as zero.	R/O	0
5	Interrupt Enable	1 = For port 0, the Interrupt function through the $\overline{QINT}/CI-$ pin will be active and the AUI port, if selected (bit 2 set), will operate in PCI mode. 0 = For port 0, the interrupt function will not be available. Ports 1, 2, and 3 are don't cares. Not effected by SRESET.	R/W	1
4	Disable Link Pulse Generation	1 = Link pulses sent from the 10BASE-T transmitter are suppressed; 0 = Link Pulses not suppressed.	R/W	0
3	Auto Receive Polarity Correction Disable	1 = Polarity correction circuit at the front-end of the receive port disabled (when the receive function is disabled, the receive port will only accept frames with correct polarity); 0 = Self-correcting polarity circuit will be enabled at the receive interface of the device.	R/W	0
2	AUI Select Enable	1 = For port 0, Attachment Unit Interface is substituted for 10BASE-T port 0; 0 = Port 0 reverts to 10BASE-T function. Ports 1, 2, and 3 are don't cares. Not effected by SRESET.	R/W	0
1	Extended Distance Enable	1 = 10BASE-T receive squelch thresholds reduced for reception of frames farther than 100 meters. 0 = Squelch thresholds at standard 100 meter distance.	R/W	0
0	SQE_TEST Disable	1 = SQE heartbeat, which occurs after each transmission, disabled; 0 = Heartbeat asserted on QCLSN approximately 1 μ s after transmission, for a duration of 1 μ s; When the port is configured for full duplex, heartbeat signal is automatically disabled.	R/W	0

Status Register (Reg 19)

The Status Register (Reg 19) contains Read/Only (R/O) and Cleared on Read (COR) bits which indicate

status beyond the Auto-Negotiation status registers. This register is duplicated for each port.

Bit(s)	Name	Description	Read/Write	Default/Reset
15:3	Reserved	Written and read as zero.	R/O	0
2	Rate Mismatch Error	1 = Frames received underflowed or overflowed the elasticity FIFO; 0 = No rate mismatch has occurred. Register bit is cleared on Read.	R/O, COR	0
1	Receive Polarity Reversed	1 = Receive polarity of the 10BASE-T receivers is reversed; 0 = Receive polarity is correct.	R/O	0
0	Jabber Error	1 = 10BASE-T transmit circuit is in the Jabber state; 0 = 10BASE-T transmit circuit not in the Jabber state. This bit is automatically cleared when the jabber condition terminates.	R/O	0

Error Mask Register (Reg 20)

The Error Mask Register (Reg 20) determines which errors will be reported in the Summary Register (Reg 16). The Error Mask Register contains Read/Write

(R/W) or Read/Only (R/O) bits. If an error does occur and the Mask enable bit is set the Error bit in the Summary Register (Reg 17) will not be asserted. This register is duplicated for each port.

Table 19. Error Mask Register (Reg 20)

Bit(s)	Name	Description	Read/Write	Default/Reset
15:3	Reserved	Written and read as zero.	R/O	0
2	Rate Mismatch Error Enabled	1 = Rate Mismatch Error reportable in the Summary Register; 0 = Rate Mismatch Error not reportable in the Summary Register.	R/W	0
1	Receive Polarity Reversed Error Enable	1 = Receive Polarity Reversed reportable in the Summary Register as an Error; 0 = Receive Polarity Reversed bit not reportable as an error in the Summary Register.	R/W	0
0	Jabber Error Enable	1 = Jabber error reportable in the Summary Register; 0 = Jabber error not reportable in the Summary Register.	R/W	0

SYSTEM APPLICATIONS

10 Mbps Ethernet Switch

The QuEST device is targeted for use in 10BASE-T switching applications. The QuEST device provides four 10BASE-T receive and transmit ports.

Optionally, one of the 10BASE-T ports can be reprogrammed as an AUI. The four Ethernet ports are multiplexed into the QuASI interface which interfaces to a switching subsystem. The QuEST device provides 10BASE-T filterless technology and a reduced pin count which enables high levels of switch integration.

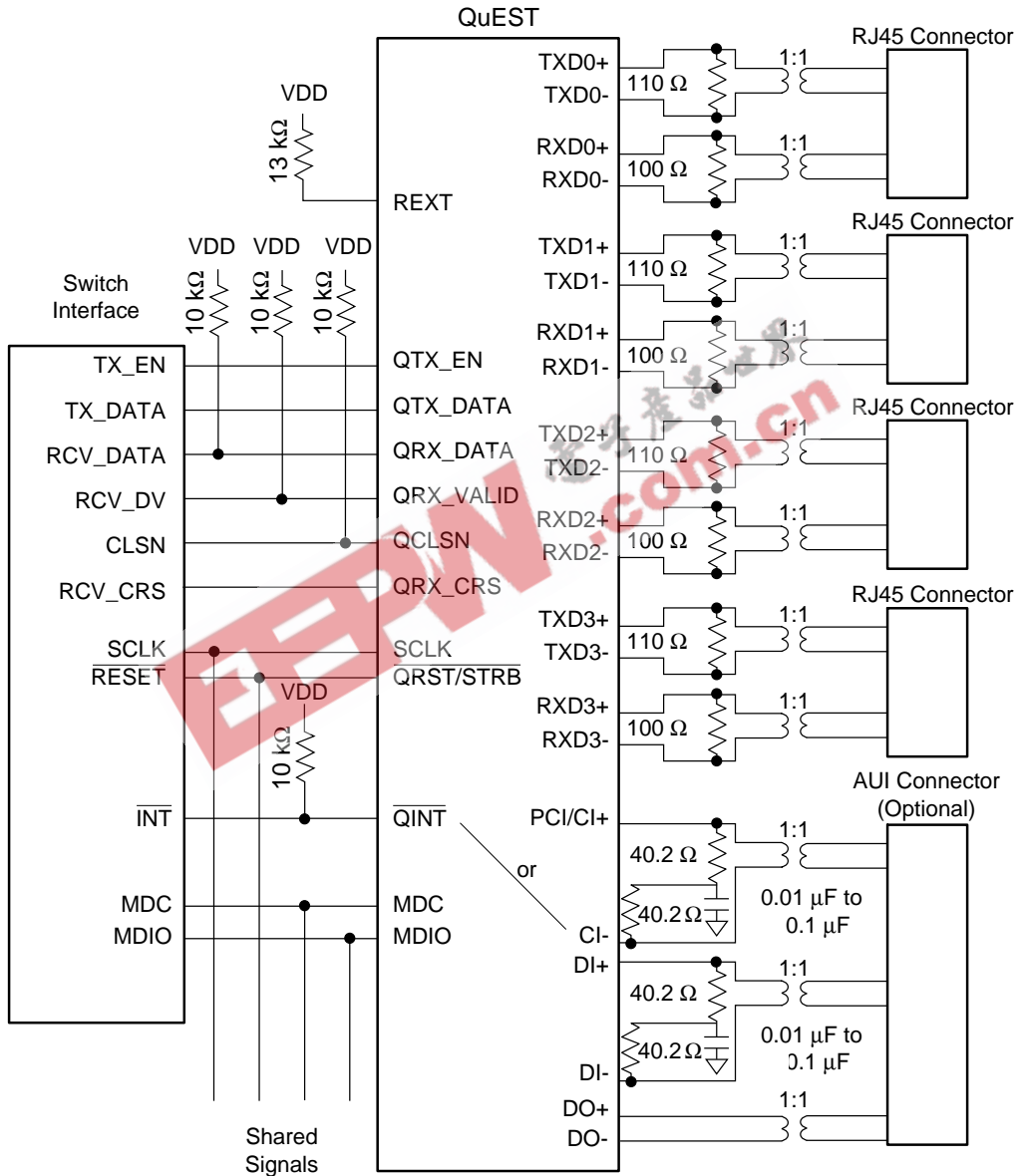

Note: If \overline{QINT} and the AUI port are used, a special circuit (not shown) is needed for PCI. Optional 10K resistors are used to set internal address match for Management Address.

21173B-5

Figure 1. QuEST Device Application Diagram

ABSOLUTE MAXIMUM RATINGS

Storage Temperature -65°C to +150°C
 Ambient Temperature 0°C to +70°C
 Supply Voltage -0.3 V to +6.0 V
 DC Voltage applied to any Pin can be . . $V_{SS} - 0.5$ V to $V_{DD} + 0.5$ V

Stresses above those listed under ABSOLUTE MAXIMUM RATINGS may cause permanent device failure. Functionality at or above these limits is not implied or recommended. Exposure to Absolute Maximum Ratings for extended periods may affect device reliability. Programming conditions may differ.

OPERATING RANGES

Commercial (C) Devices

Temperature (TA) 0°C to +70°C
 Supply Voltages (V_{DDIO} , V_{DD} , V_{DDTX}) +5 V \pm 5%
 Supply Voltages (V_{DDIO}) +3.3 V \pm 5%
Operating ranges define those limits between which the functionality of the device is guaranteed.

DC CHARACTERISTICS over operating ranges unless otherwise specified

Parameter Symbol	Parameter Description	Test Conditions	Min	Max	Unit
Digital Interface Input Voltage					
V_{IL}	Input LOW Voltage		-	0.8	V
V_{IH}	Input HIGH Voltage		2.0	$V_{DDIO} + 0.5$	V
Digital Interface Output Voltage					
V_{OL}	Output LOW Voltage	$I_{OL} = 4.0$ mA		0.4	V
V_{OH}	Output HIGH Voltage	$V_{DDIO} = 5.0$ Volts $I_{OH} = -0.4$ mA	2.4	-	V
V_{OH1}	Output HIGH Voltage (QRX_VALID, QRX_DATA, QRX_CRS, QCLSN, MDIO)	$V_{DDIO} = 3.3$ Volts $I_{OH} = -0.4$ mA	2.4	-	V
Digital Input Leakage					
I_{IH}	Input Leakage Current High	$0 < V_{IN} < V_{DDIO}$	-	10	μ A
I_{IL}	Input Leakage Current Low	$0 < V_{IN} < V_{DDIO}$	-	-10	μ A
Attachment Unit Interface (AUI)					
I_{IAZD}	Input Current at DI+ and DI-	$V_{SSAUI} < V_{IN} < V_{DD}$	-500	+500	μ A
I_{IAXC}	Input Current at CI+ and CI-	$V_{SSAUI} < V_{IN} < V_{DD}$	-500	+500	μ A
V_{AOD}	Differential Output Voltage (DO+)-(DO-)	$R_L = 80.4 \Omega$	620	1100	mV
V_{AODOFF}	Transmit Differential Output Idle Voltage	$R_L = 80.4 \Omega$	-40	+40	mV
I_{AODOFF}	Transmit Differential Output Idle Current	$R_L = 80.4 \Omega$ (Note 1)	-1	+1	mA
V_{AOCM}	Transmit Output Common Mode Voltage	$R_L = 80.4 \Omega$	2.5	V_{DD}	V
V_{AODI}	DO \pm Differential Output Voltage Imbalance	$R_L = 80.4 \Omega$	-25	+25	mV

Parameter Symbol	Parameter Description	Test Conditions	Min	Max	Unit
Attachment Unit Interface (AUI) (continued)					
V_{ATH}	Receive Data Differential Input Threshold CI/DI_{\pm}	(Note 1)	-35	+35	mV
V_{ASQ}	DI_{\pm} and CI_{\pm} Differential Input Threshold (Squelch)		-275	-160	mV
V_{AIDV}	DI_{\pm} and CI_{\pm} Differential Mode Input Voltage Range		-2.5	+2.5	V
V_{AICM}	DI_{\pm} and CI_{\pm} Input Bias Voltage	$I_{IN} = 0$ mA	$V_{DD} - 3.0$	$V_{DD} - 1.0$	V
10BASE-T Receive Interface					
I_{IRXD}	Input Current at RXD_{\pm}	$V_{SSRX} < V_{IN} < V_{DD}$	-500	500	μ A
R_{RXD}	RXD_{\pm} Differential Input Resistance	(Note 1)	10		k Ω
V_{TIVB}	$RXD+$, $RXD-$ Open Circuit Input Voltage (Bias)	$I_{IN} = 0$ mA	$V_{DDTX} - 3.0$	$V_{DDTX} - 1.5$	V
V_{TIDV}	Differential Mode Input Voltage Range (RXD_{\pm})	$V_{DDTX} = +5.0$ V	-3.1	+3.1	V
V_{TSQ+}	RXD Positive Squelch Threshold (Peak)	Sinusoid $5 \text{ MHz} \leq f \leq 10 \text{ MHz}$	300	520	mV
V_{TSQ-}	RXD Negative Squelch Threshold (Peak)	Sinusoid $5 \text{ MHz} \leq f \leq 10 \text{ MHz}$	-520	-300	mV
V_{THS+}	RXD Post-Squelch Positive Threshold (Peak)	Sinusoid $5 \text{ MHz} \leq f \leq 10 \text{ MHz}$	150	293	mV
V_{THS-}	RXD Post-Squelch Negative Threshold (Peak)	Sinusoid $5 \text{ MHz} \leq f \leq 10 \text{ MHz}$	-293	-150	mV
V_{LTSQ+}	RXD Positive Squelch Threshold (Peak). Extended Distance Mode.	Sinusoid $5 \text{ MHz} \leq f \leq 10 \text{ MHz}$	180	312	mV
V_{LTSQ-}	RXD Negative Squelch Threshold (Peak). Extended Distance Mode.	Sinusoid $5 \text{ MHz} \leq f \leq 10 \text{ MHz}$	-312	-180	mV
V_{LTHS+}	RXD Post-Squelch Positive Threshold (Peak). Extended Distance Mode.	Sinusoid $5 \text{ MHz} \leq f \leq 10 \text{ MHz}$	90	175	mV
V_{LTHS-}	RXD Post-Squelch Negative Threshold (Peak). Extended Distance Mode.	Sinusoid $5 \text{ MHz} \leq f \leq 10 \text{ MHz}$	-175	-90	mV
V_{RXDTH}	RXD Switching Threshold	(Note 1)	-35	35	mV
Power Supply Current					
I_{DDTX}	Power Supply Current (All 10BASE-T Ports Transmitting)			275	mA

Note: 1. Parameter not tested.

KEY TO SWITCHING WAVEFORMS

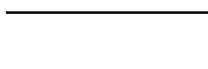
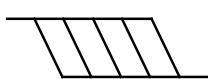
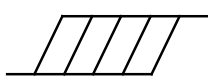
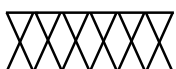
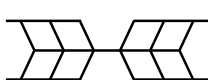
WAVEFORM	INPUTS	OUTPUTS
	Must be Steady	Will be Steady
	May Change from H to L	Will be Changing from H to L
	May Change from L to H	Will be Changing from L to H
	Don't Care, Any Change Permitted	Changing, State Unknown
	Does Not Apply	Center Line is High-Impedance "Off" State

KS000010-PAL

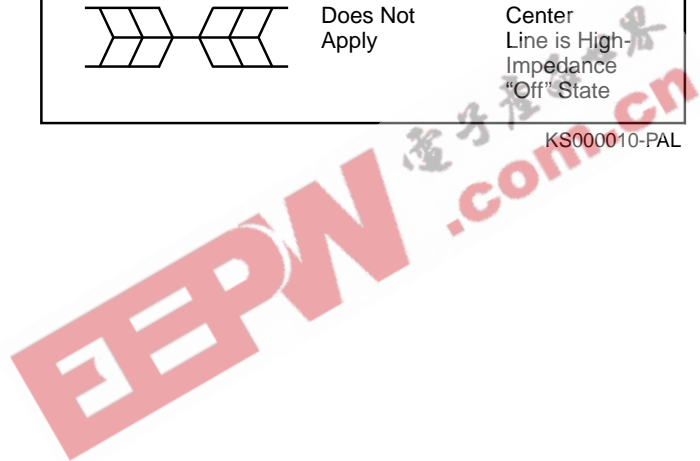

QuASI Interface

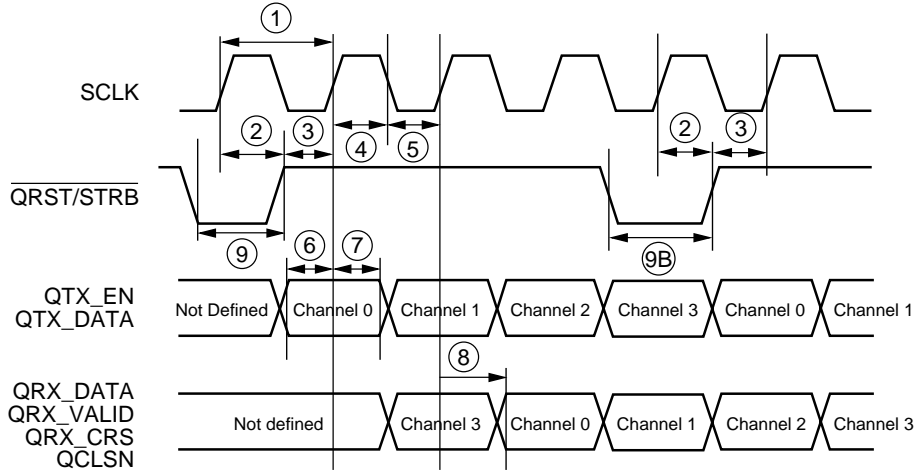

21173B-6

Figure 2. QuASI Interface Timing Diagram

No.	Symbol	Parameter Description	Min	Max	Unit
1	t_{MS11}	SCLK Period (40 MHz, 100 ppm). Not Tested.	24.9975	25.0025	ns
2	t_{MS12}	QRST/STRB hold time after rising edge of SCLK.	3		ns
3	t_{MS13}	QRST/STRB setup time to rising edge of SCLK.	5		ns
4	t_{MS14}	SCLK high time.	10		ns
5	t_{MS15}	SCLK low time.	10		ns
6	t_{MS16}	QTX_EN and QTX_DATA setup time to rising edge of SCLK.	3		ns
7	t_{MS17}	QTX_EN and QTX_DATA hold time from rising edge of SCLK.	5		ns
8	t_{MS18}	QRX_DATA, QRX_VALID, QCLSN, QRX_CRS delay until valid from rising edge of SCLK.	4	17.5	ns
9	t_{MS19}	Reset Pulse Width of QRST/STRB. Parameter tested functionally.	1		μ s
9B	t_{MS19B}	Strobe Pulse Width of QRST/STRB.	9	25	ns

Management Interface

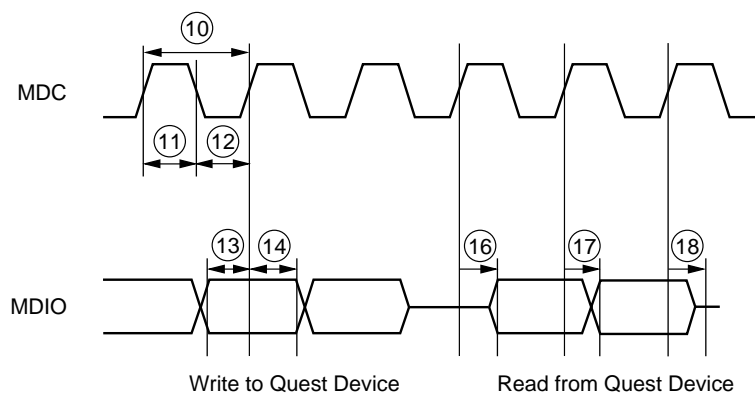

21173B-7

Figure 3. Management Interface Timing Diagram

No.	Symbol	Parameter Description	Min	Max	Unit
10	t_{MII0}	MDC Clock Period.	50	—	ns
11	t_{MII1}	MDC high pulse.	20	—	ns
12	t_{MII2}	MDC low pulse.	20	—	ns
13	t_{MII3}	MDIO setup to rising edge of MDC.	10	—	ns
14	t_{MII4}	MDIO hold from rising edge of MDC.	5	—	ns
16	t_{MII6}	MDIO enable from rising edge of MDC.	0	20	ns
17	t_{MII7}	MDIO valid from rising edge of MDC.	0	20	ns
18	t_{MII8}	MDIO TRI-STATE® delay from rising edge of MDC.	0	20	ns

Fast Link Pulse Timing

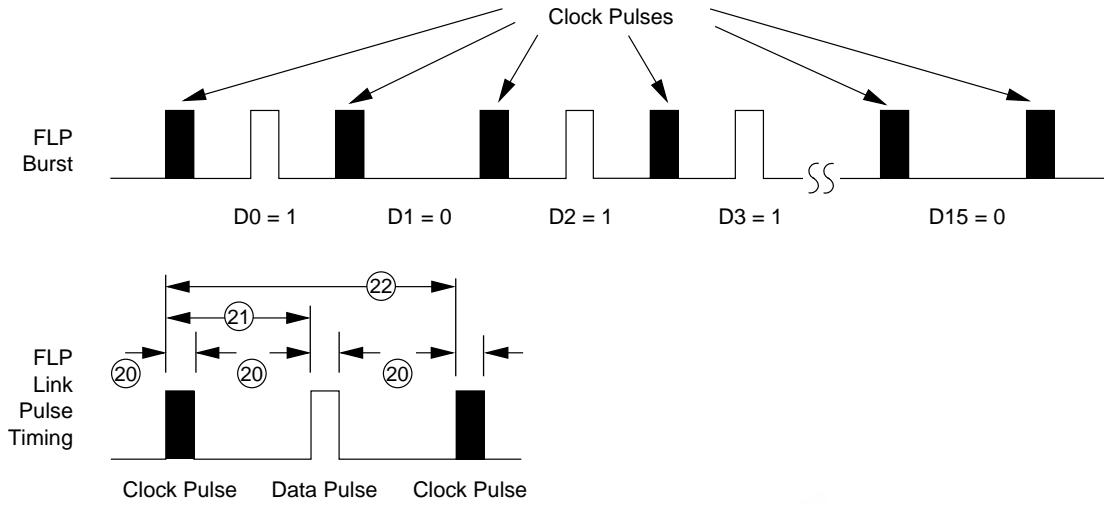

21173B-8

Figure 4. Fast Link Pulse Timing Diagram

No.	Symbol	Parameter Description	Min	Max	Unit
20	t_{FLP0}	Link Pulse Width.	80	120	ns
21	t_{FLP1}	Clock to Data Delay.	55.5	69.5	μ s
22	t_{FLP2}	Clock to Clock Delay.	111	139	μ s
23		Total Pulses in FLP Burst.	17	33	No.
24		FLP Burst to FLP Burst.	8	24	ms

Attachment Unit Interface (AUI)

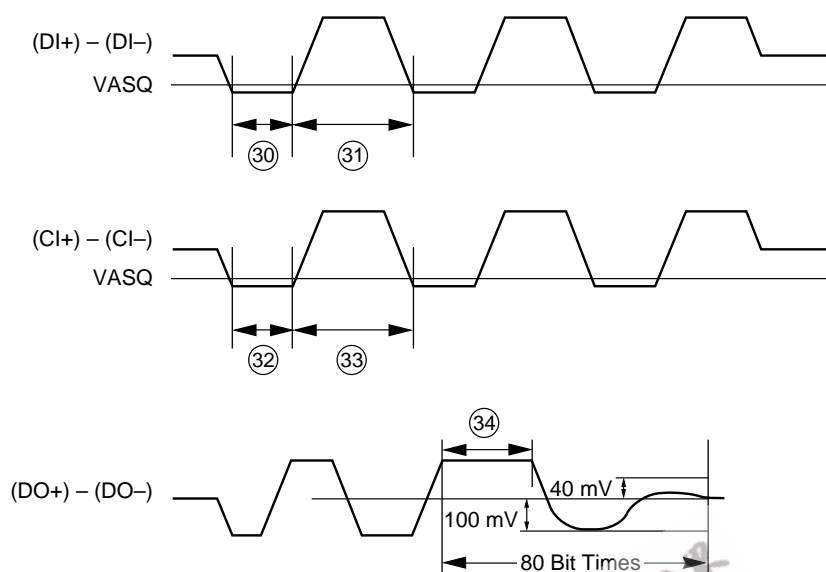

21173B-9

Figure 5. AUI Timing Diagram

No.	Symbol	Parameter Description	Min	Max	Unit
30	t_{PWODI}	DI Pulse Width Accept/Reject Threshold.	15	45	ns
31	t_{PWKDI}	DI Pulse Width Maintain/Turn-Off Threshold.	136	200	ns
32	t_{PWOCI}	CI Pulse Width Accept/Reject Threshold.	10	26	ns
33	t_{PWKCI}	CI Pulse Width Maintain/Turn-Off Threshold.	90	160	ns
34	t_{DOETD}	DO± End of Transmission Delimiter.	275	375	ns

10BASE-T Interface

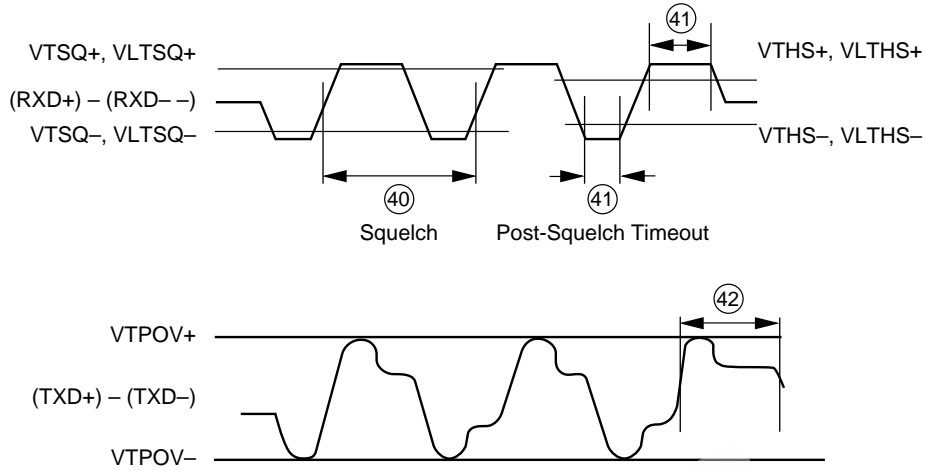

21173B-10

Figure 6. 10BASE-T Interface Timing Diagram

No.	Symbol	Parameter Description	Min	Max	Unit
40	t_{TP1}	RXD Frequency Rejection.	—	15	MHz
41	t_{TP2}	RXD High/Low Frequency Time-out.	160	180	ns
42	t_{TP2}	TXD± End of Transmission Delimiter.	250	375	ns

PHYSICAL DIMENSIONS

PL 044

44-Pin Plastic LCC (Measured in inches)

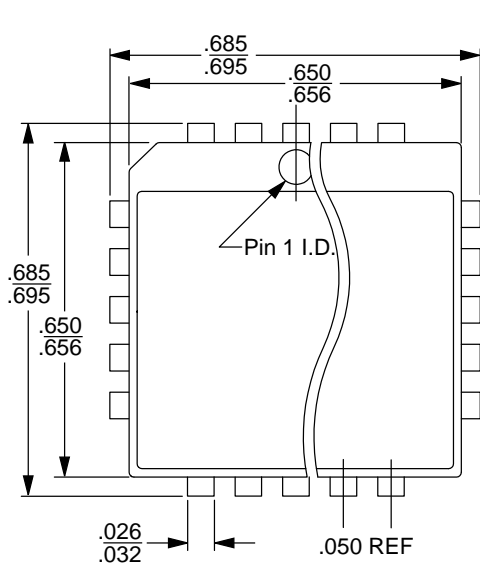

TOP VIEW

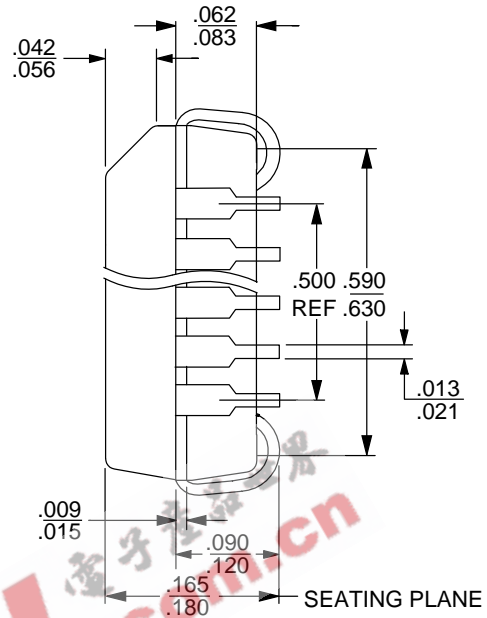

SIDE VIEW

16-038-SQ
 PL 044
 DA78
 6-28-94 ae

Trademarks

Copyright © 1997 Advanced Micro Devices, Inc. All rights reserved.

AMD, the AMD logo, and combinations thereof are trademarks of Advanced Micro Devices, Inc.

QuEST is a trademark of Advanced Micro Devices, Inc.

Product names used in this publication are for identification purposes only and may be trademarks of their respective companies.