

# Am79C982

## basic Integrated Multiport Repeater (*bIMR*)

### DISTINCTIVE CHARACTERISTICS

- Fully backward-compatible with existing IMR/IMR+ device non-managed hub designs
  - Pin/socket-compatible with the Am79C980 (IMR) and Am79C981 (IMR+) devices
- Repeater functions comply with IEEE 802.3 Repeater Unit specifications
- Four and eight 10BASE-T port options available
- Low-cost, flexible solutions suitable for non-managed repeater designs
- Integral 10BASE-T transceivers utilize the required predistortion transmission technique
- Attachment unit interface (AUI) port allows connectivity with 10BASE-5 (Ethernet) and 10BASE-2 (Cheapernet) networks, as well as 10BASE-F and/or Fiber Optic Inter-Repeater Link (FOIRL) segments
- Minimum mode facilitates LED implementation and provides four LED display options for port status
- Built-in pulse stretching for carrier sense LED display
- On-board PLL, Manchester encoder/decoder, LED display and FIFO
- Expandable to increase number of repeater ports
- All ports can be separately isolated (partitioned) in response to excessive collision conditions or fault conditions
- Network management and optional features are accessible through a dedicated serial management port
- Twisted-pair Link Test capability conforming to the 10BASE-T standard. The receive Link Test function can be optionally disabled through the management port to facilitate interoperability with devices that do not implement the Link Test function
- Programmable option of Automatic Polarity Detection and Correction permits automatic recovery due to wiring errors
- Full amplitude and timing regeneration for retransmitted waveforms
- Preamble loss effects eliminated by deep FIFO
- CMOS device features high integration and low power with a single +5 V supply

### GENERAL DESCRIPTION

The *basic* Integrated Multiport Repeater (*bIMR*<sup>™</sup>) chip is a VLSI circuit that provides a system-level solution to designing a compliant 802.3 repeater incorporating 10BASE-T transceivers. The device integrates the Repeater functions specified by Section 9 of the IEEE 802.3 standard and twisted-pair Transceiver functions complying to the 10BASE-T standard. The Am79C982-4 provides four and the Am79C982-8 provides eight integral twisted-pair medium attachment units (MAUs), and an attachment unit interface (AUI) port in an 84-pin plastic leaded chip carrier (PLCC).

A network based on the 10BASE-T standard uses unshielded twisted-pair cables, therefore providing an economical solution to networking by allowing the use

of low-cost unshielded twisted-pair (UTP) cable or existing telephone wiring.

The total number of ports per repeater unit can be increased by connecting multiple *bIMR* devices through their expansion ports, hence minimizing the total cost per repeater port. Furthermore, a general-purpose attachment unit interface (AUI) provides connection capability to 10BASE-5 (Ethernet) and 10BASE-2 (Cheapernet) coaxial networks, as well as 10BASE-F and/or Fiber Optic Inter-Repeater Link (FOIRL) fiber segments. Network management and test functions are provided through TTL-compatible I/O pins.

The device is fabricated in CMOS technology and requires a single +5 V supply.

**BLOCK DIAGRAM**

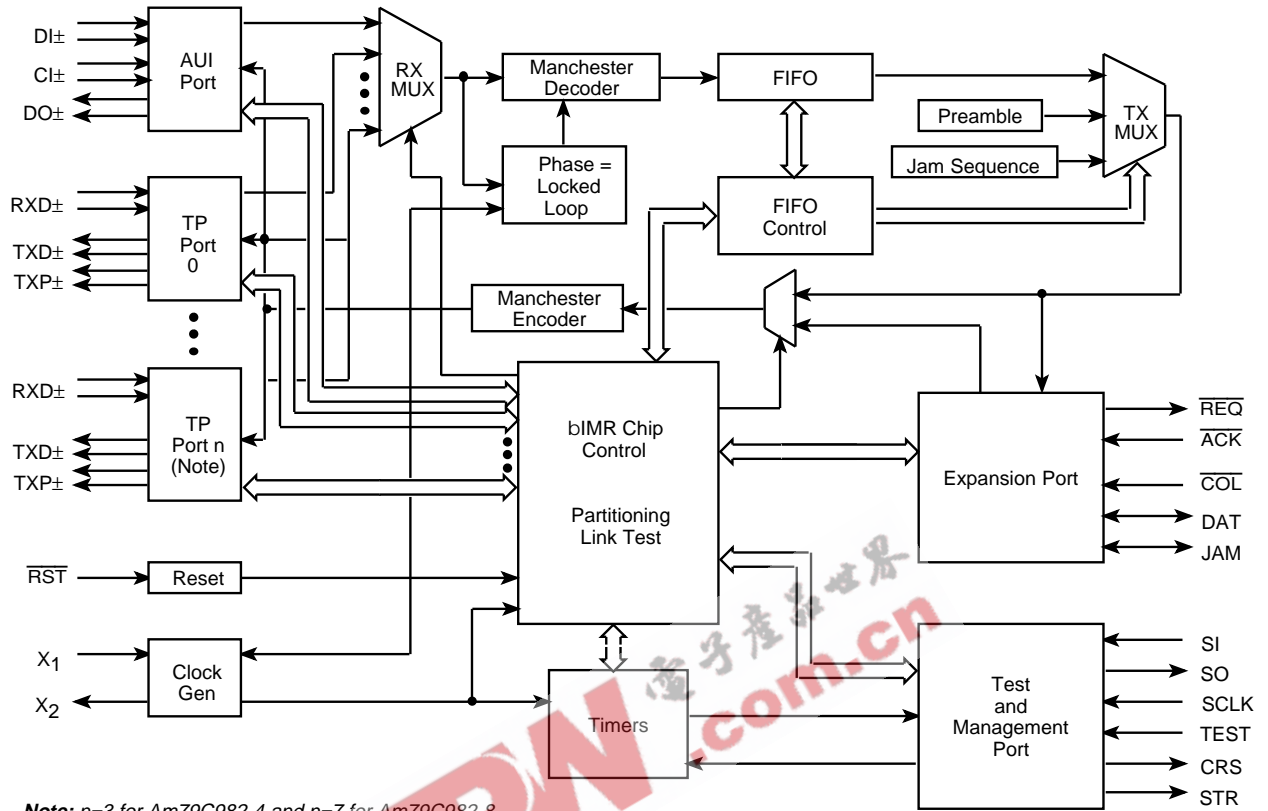

Note: n=3 for Am79C982-4 and n=7 for Am79C982-8.

19406B-1

**RELATED AMD PRODUCTS**

Part No.	Description
Am79C98	Twisted Pair Ethernet Transceiver (TPEX)
Am79C100	Twisted Pair Ethernet Transceiver Plus (TPEX+)
Am7996	IEEE 802.3/Ethernet/Cheapernet Transceiver
Am79C981	Integrated Multiport Repeater Plus (IMR+)
Am79C987	Hardware Implemented Management Information Base™ (HIMIB™)
Am79C940	Media Access Controller for Ethernet (MACE™)
Am79C90	CMOS Local Area Network Controller for Ethernet (C-LANCE)
Am79C900	Integrated Local Area Communications Controller™ (ILACC™)
Am79C960	PCnet-ISA Single-Chip Ethernet Controller (for ISA bus)
Am79C961	PCnet-ISA+ Single-Chip Ethernet Controller for ISA (with Microsoft® Plug n' Play® Support)
Am79C965	PCnet-32 Single-Chip 32-Bit Ethernet Controller
Am79C970	PCnet-PCI Single-Chip Ethernet Controller (for PCI bus)
Am79C974	PCnet-SCSI Combination Ethernet and SCSI Controller for PCI Systems

CONNECTION DIAGRAM

PLCC

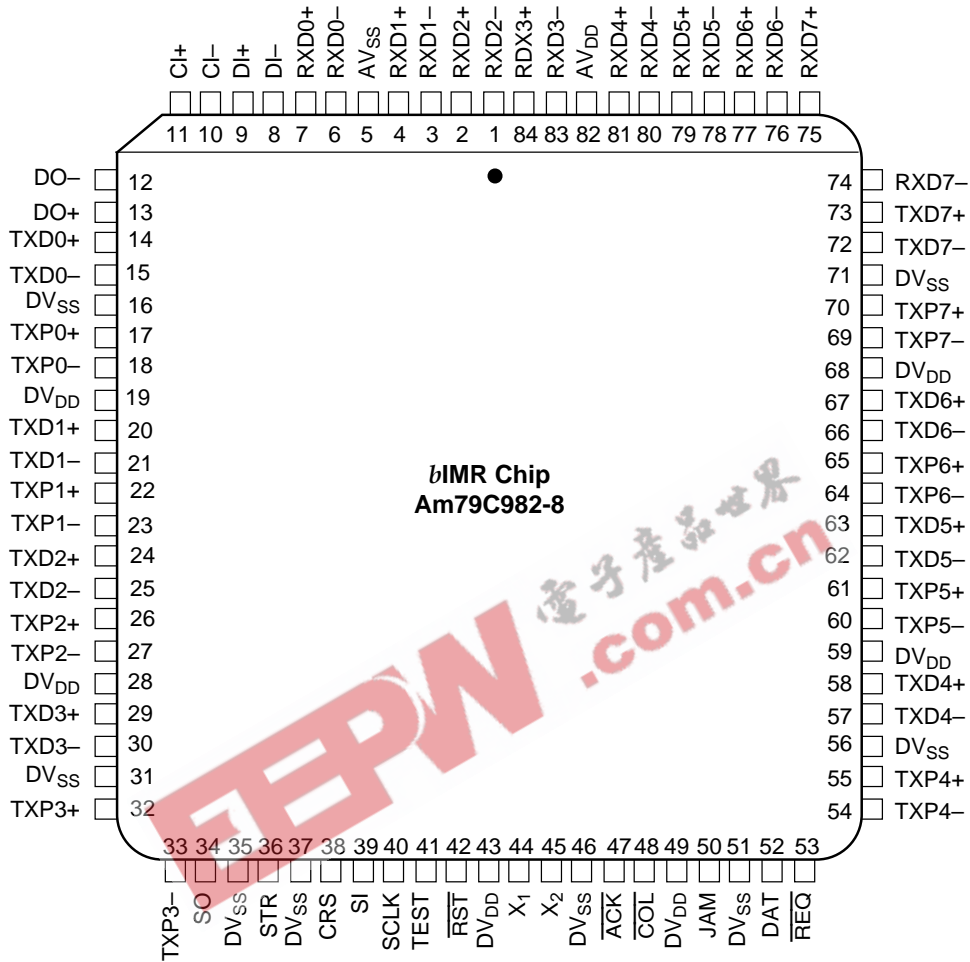

19406B-2

CONNECTION DIAGRAM

PLCC

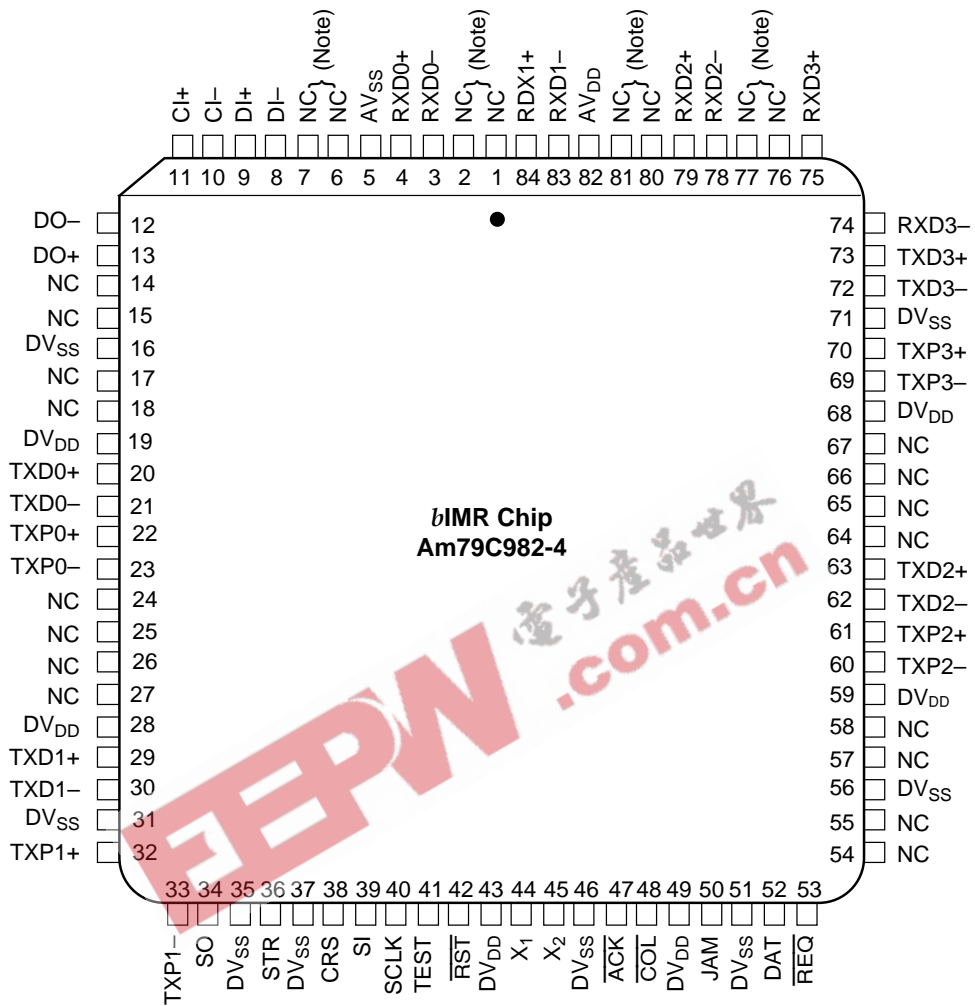

19406B-3

**Note:**  
Recommended to be tied together.

LOGIC SYMBOL

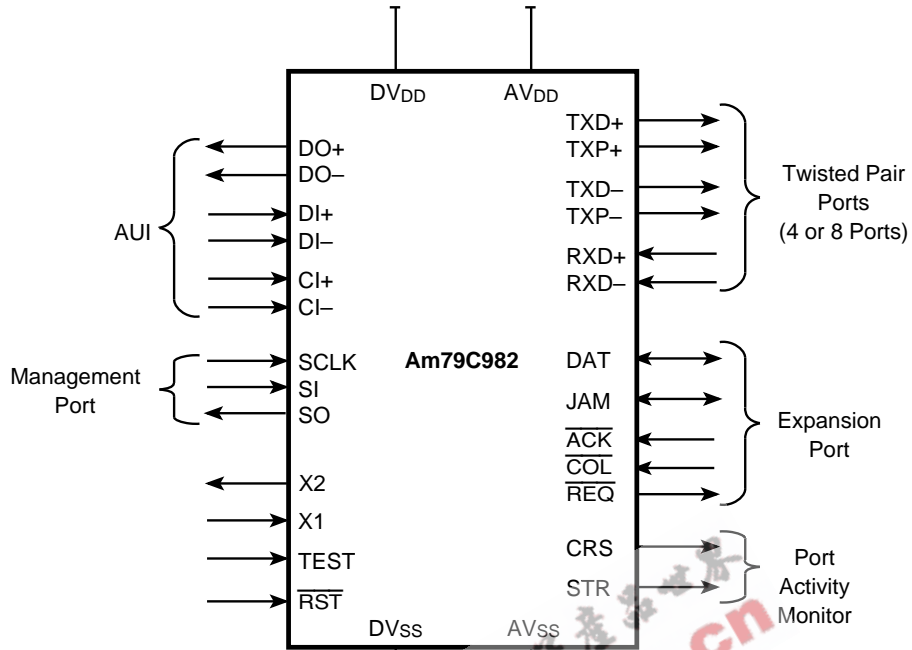

19406B-4

LOGIC DIAGRAM

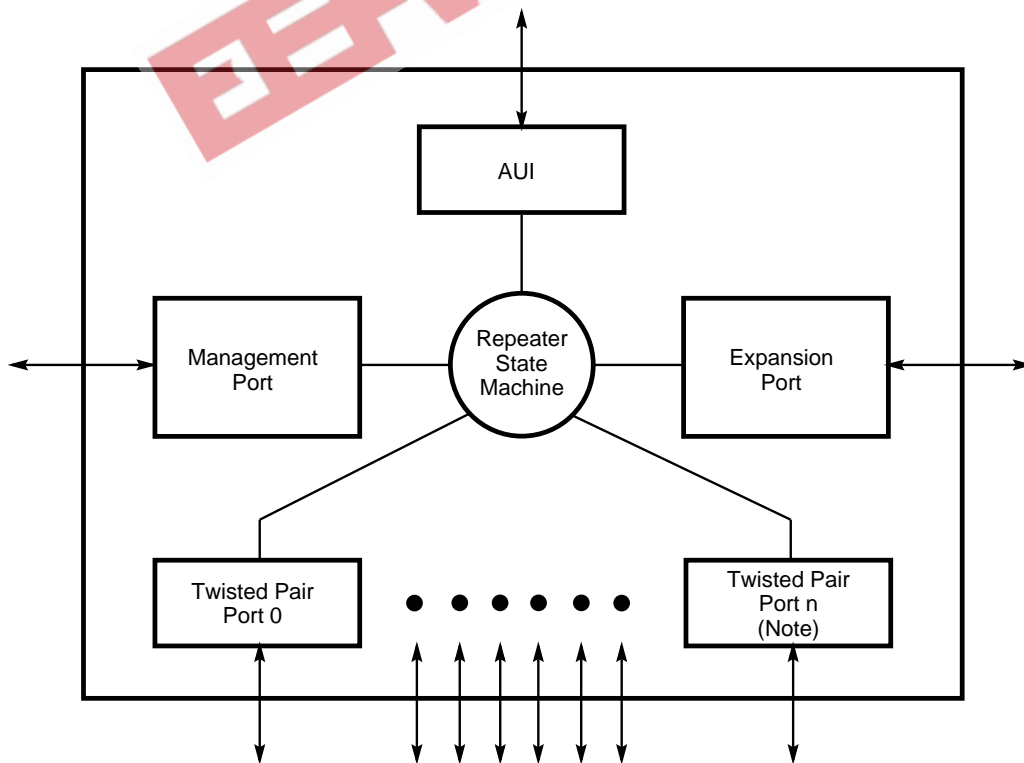

Note: n=3 for Am79C982-4 and n=7 for Am79C982-8.

19406B-5

## ORDERING INFORMATION

### Standard Products

AMD standard products are available in several packages and operating ranges. The order number (valid combination) is formed by a combination of the elements below.

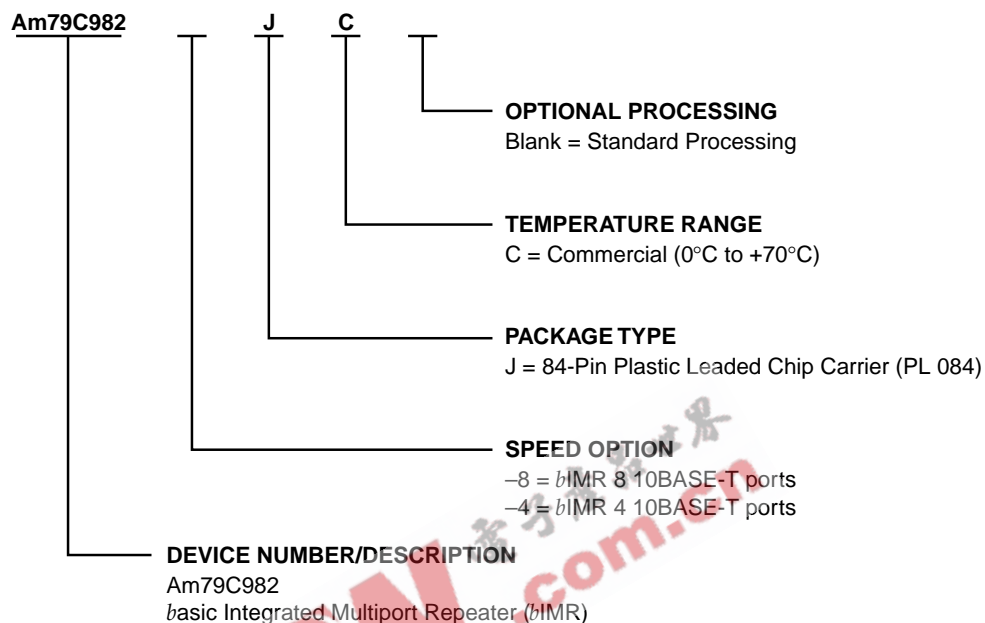

Valid Combinations	
Am79C982-4	JC
Am79C982-8	JC

### Valid Combinations

Valid combinations list configurations planned to be supported in volume for this device. Consult the local AMD sales office to confirm availability of specific valid combinations and to check on newly released combinations.

## PIN DESCRIPTION

### $\overline{\text{ACK}}$

#### Acknowledge Input, Active LOW

When this input is asserted, it signals to the requesting *bIMR* device that it may control the DAT and JAM pins. If the *bIMR* chip is not requesting control of the DAT line ( $\overline{\text{REQ}}$  pin HIGH), then the assertion of the  $\overline{\text{ACK}}$  signal indicates the presence of valid collision status on the JAM or valid data on the DAT line.

### $\text{AV}_{\text{DD}}$

#### Analog Power Power Pin

These pins supply +5 V to the RXD+/- receivers, the DI+/- and CI+/- receivers, the DO+/- drivers, the internal PLL, and the internal voltage reference of the *bIMR* device. These power pins should be decoupled and kept separate from other power and ground planes.

### $\text{AV}_{\text{SS}}$

#### Analog Ground Ground Pin

These pins are the 0 V reference for  $\text{AV}_{\text{DD}}$ .

### $\overline{\text{COL}}$

#### Expansion Collision Input, Active LOW

When this input is asserted by an external arbiter, it signifies that more than one *bIMR* device is active and that each *bIMR* device should generate the Collision Jam sequence independently.

### $\text{CI+}, \text{CI-}$

#### Control In Input

AUI port differential receiver. Signals comply with IEEE 802.3, Section 7.

### CRS

#### Carrier Sense Output

The states of the internal carrier sense signals for the AUI port and the eight twisted-pair ports are serially output on this pin continuously. The output serial bit stream is synchronized to the  $X_1$  clock.

The resolution of the CRS signal is 2 ms. The incoming data is sampled repeatedly during each 2-ms period. If any activity occurs (regardless of length) during any 2-ms period, this activity will be latched. At the start of the next 2-ms period the *bIMR* device will examine the latches for each port. For any port for which activity

occurred, the corresponding bit in the CRS output stream will remain set for the 2-ms period and will be reset at the end of this period.

### DAT

#### Data Input/Output/3-State

In non-collision conditions, the active *bIMR* device will drive DAT with NRZ data, including regenerated preamble. During collision, when JAM = HIGH, DAT is used to signal a multiport (DAT = 0) or single-port (DAT = 1) condition.

When  $\overline{\text{ACK}}$  is not asserted, DAT is in high impedance. If  $\overline{\text{REQ}}$  and  $\overline{\text{ACK}}$  are both asserted, then DAT is an output. If  $\overline{\text{ACK}}$  is asserted and  $\overline{\text{REQ}}$  not asserted, then DAT is an input.

This pin needs to be either pulled up or pulled down through a high-value resistor.

### $\text{DI+}, \text{DI-}$

#### Data In Input

AUI port differential receiver. Signals comply with IEEE 802.3, Section 7.

### $\text{DO+}, \text{DO-}$

#### Data Out Output

AUI port differential driver. Signals comply with IEEE 802.3, Section 7.

### $\text{DV}_{\text{DD}}$

#### Digital Power Power Pin

These pins supply +5 V to the logic portions of the *bIMR* chip and the TXP+/-, TXD+/-, and DO+/- line drivers.

### $\text{DV}_{\text{SS}}$

#### Digital Ground Ground Pin

These pins are the 0 V reference for  $\text{DV}_{\text{DD}}$ .

$\text{DV}_{\text{DD}}$ Pin #	$\text{DV}_{\text{SS}}$ Pin #	Function
19	16	TP ports 0 & 1 drivers
28	31	TP ports 2 & 3 drivers
43, 49	35, 37, 46, 51	Core logic and expansion and control pins
59	56	TP ports 4 & 5 drivers
68	71	TP ports 6 & 7 drivers

**JAM****Jam  
Input/Output/3-State**

When JAM is asserted, the state of DAT will indicate either a multiport (DAT = 0) or single-port (DAT = 1) collision condition.

When  $\overline{ACK}$  is not asserted, JAM is in high impedance. If  $\overline{REQ}$  and  $\overline{ACK}$  are both asserted, then JAM is an output. If  $\overline{ACK}$  is asserted and  $\overline{REQ}$  not asserted, then JAM is an input.

This pin needs to be either pulled up or pulled down through a high-value resistor.

 **$\overline{REQ}$** **Request  
Output, Active LOW**

This pin is driven LOW when the bIMR chip is active. A bIMR chip is active when it has one or more ports receiving or colliding or is in the state where it is still transmitting data from the internal FIFO. The assertion of this signal signifies that the bIMR device is requesting the use of the DAT and JAM lines for the transfer of repeated data or collision status to other bIMR devices.

 **$\overline{RST}$** **Reset  
Input, Active LOW**

Driving this pin LOW resets the internal logic of the bIMR device. Reset should be synchronized to the  $X_1$  clock if either expansion or port activity monitor is used.

**RXD<sub>+0-7</sub>, RXD<sub>-0-7</sub> (RXD<sub>+0-3</sub>, RXD<sub>-0-3</sub>)****Receive Data  
Input**

10BASE-T port differential receive inputs (4 or 8 ports).

**SCLK****Serial Clock  
Input**

In normal operating mode, serial data (input or output) is clocked (in or out) on the rising edge of the signal on this pin. SCLK is asynchronous to  $X_1$  and can operate up to 10 MHz. In Minimum mode, this pin, together with the SI pin, controls which information is output on the SO pin.

**SI****Serial In  
Input**

In normal operating mode, the SI pin is used for test/management serial input port. Management commands are clocked in on this pin synchronous to the SCLK input. In Minimum mode, this pin, together with the SCLK pin, controls which information is output on the SO pin.

In Minimum mode, the state of SI at the deassertion of  $\overline{RST}$  signal determines the programming of automatic polarity detection/correction for 10BASE-T ports.

**SO****Serial Out  
Output**

In normal operating mode, the SO pin is used for test/management serial output port. Management results are clocked out on this pin synchronous to the SCLK input. In Minimum mode, the SO pin is used to output the various status information serially based on the state of the SI and SCLK pins.

SCLK	SI	SO Output
0	0	TP Ports Receive Polarity Status + AUI SQE Test Error Status
0	1	Bit Rate Error (all ports)
1	0	TP Ports Link Status + AUI Loopback Status
1	1	Port Partitioning Status (all ports)

**STR****Store  
Output**

The STR pin goes HIGH for two  $X_1$  clock cycle times after the nine carrier sense bits are output on the CRS pin. Note that the carrier sense signals arriving from each port are latched internally, so that an active transition is remembered between samples.

**TEST****Test Pin  
Input, Active HIGH**

This pin should be tied LOW for normal operation. If this pin is driven HIGH, then the bIMR device can be programmed for Loopback Test mode. Also, if this pin is HIGH when the  $\overline{RST}$  pin is deasserted, the bIMR device will enter the Minimum mode. An inverted version of the  $\overline{RST}$  signal can be used to program the device into the Minimum mode.

Test	SI	Functions
0	0	Normal Management Mode
0	1	Normal Management Mode
1	0	Minimum Mode, Receive Polarity Correction Disabled
1	1	Minimum Mode, Receive Polarity Correction Enabled



**TXD<sub>+0-7</sub>, TXD<sub>-0-7</sub> (TXD<sub>+0-3</sub>, TXD<sub>-0-3</sub>)****Transmit Data  
Output**

10BASE-T port differential drivers (4 or 8 ports).

**TXP<sub>+0-7</sub>, TXP<sub>-0-7</sub> (TXP<sub>+0-3</sub>, TXP<sub>-0-3</sub>)****Transmit Predistortion  
Output**

10BASE-T transmit waveform predistortion control differential outputs (4 or 8 ports).

**X<sub>1</sub>****Crystal 1  
Crystal Connection**

The internal clock generator uses a 20 MHz crystal attached to pins X<sub>1</sub> and X<sub>2</sub>. Alternatively, an external 20MHz CMOS clock signal can be used to drive this pin.

**X<sub>2</sub>****Crystal 2  
Crystal Connection**

The internal clock generator uses a 20 MHz crystal attached to pins X<sub>1</sub> and X<sub>2</sub>. If an external clock source is used, this pin should be left unconnected.

EEPW 电子产品世界  
.com.cn

## FUNCTIONAL DESCRIPTION

The Am79C982 Basic Integrated Multiport Repeater device is a single chip implementation of an IEEE 802.3/Ethernet repeater (or hub). It is offered either with four or eight integral 10BASE-T ports plus one AUI port comprising the basic repeater. The bIMR device is also expandable, enabling the implementation of high port count repeaters based on several bIMR devices.

The bIMR chip complies with the full set of repeater basic functions as defined in section 9 of ISO 8802.3 (ANSI/IEEE 802.3c). These functions are summarized below.

### Repeater Function

If any single network port senses the start of a valid packet on its receive lines, then the bIMR device will retransmit the received data to all other enabled network ports. The repeated data will also be presented on the DAT line to facilitate multiple-bIMR device repeater applications.

### Signal Regeneration

When re-transmitting a packet, the bIMR device ensures that the outgoing packet complies with the 802.3 specification in terms of preamble structure, voltage amplitude, and timing characteristics. Specifically, data packets repeated by the bIMR chip will contain a minimum of 56 preamble bits before the Start of Frame Delimiter. In addition, the voltage amplitude of the repeated packet waveform will be restored to levels specified in the 802.3 specification. Finally, signal symmetry is restored to data packets repeated by the bIMR device, removing jitter and distortion caused by the network cabling.

### Jabber Lockup Protection

The bIMR chip implements a built-in jabber protection scheme to ensure that the network is not disabled due to transmission of excessively long data packets. This protection scheme will automatically interrupt the transmitter circuits of the bIMR device for 96-bit times if the bIMR device has been transmitting continuously for more than 65,536-bit times. This is referred to as MAU Jabber Lockup Protection (MJLP). The MJLP status for the bIMR chip can be read through the Management Port using the Get MJLP Status command (M bit returned).

### Collision Handling

The bIMR chip will detect and respond to collision conditions as specified in 802.3. A multiple-bIMR device repeater implementation also complies with the 802.3 specification due to the inter-bIMR chip status communication provided by the expansion port. Specifically, a repeater based on one or more bIMR devices will handle the transmit collision and one-port-left collision

conditions correctly as specified in Section 9 of the 802.3 specification.

### Fragment Extension

If the total packet length received by the bIMR device is less than 96 bits, including preamble, the bIMR chip will extend the repeated packet length to 96 bits by appending a Jam sequence to the original fragment.

### Auto Partitioning/Reconnection

Any of the integral TP ports and AUI port can be partitioned under excessive duration or frequency of collision conditions. Once partitioned, the bIMR device will continue to transmit data packets to a partitioned port, but will not respond (as a repeater) to activity on the partitioned port's receiver. The bIMR chip will monitor the port and reconnect it once certain criteria indicating port 'wellness' are met. The criteria for reconnection are specified by the 802.3 standard. In addition to the standard reconnection algorithm, the bIMR device implements an alternative reconnection algorithm which provides a more robust partitioning function for the TP ports and/or the AUI port. Each TP port and the AUI port are partitioned and/or reconnected separately and independently of other network ports.

Either one of the following conditions occurring on any enabled bIMR device network port will cause the port to partition:

- a. A collision condition exists continuously for a time between 1024- to 2048-bit times (AUI port—SQE signal active; TP port—simultaneous transmit and receive)
- b. A collision condition occurs during each of 32 consecutive attempts to transmit to that port.

Once a network port is partitioned, the bIMR device will reconnect that port if the following is met:

- a. Standard reconnection algorithm—A data packet longer than 512-bit times (nominal) is transmitted or received by the partitioned port without a collision.
- b. Alternate reconnection algorithm—A data packet longer than 512-bit times (nominal) is transmitted by the partitioned port without a collision.

The reconnection algorithm option (standard or alternate) is a global function for the TP ports, i.e. all TP ports use the same reconnection algorithm. The AUI reconnection algorithm option is programmed independently of the TP port reconnection option.

### Link Test

The integral TP ports implement the Link Test function as specified in the 802.3 10BASE-T standard. The bIMR device will transmit Link Test pulses to any TP port after

that port's transmitter has been inactive for more than 8 to 17 ms. Conversely, if a TP port does not receive any data packets or Link Test pulses for more than 65 to 132 ms and the Link Test function is enabled for that port then that port will enter link fail state. A port in link fail state will be disabled by the bIMR chip (repeater transmit and receive functions disabled) until it receives either four consecutive Link Test pulses or a data packet. The Link Test receive function itself can be disabled via the bIMR chip management port on a port-by-port basis to allow the bIMR device to interoperate with pre-10BASE-T twisted pair networks that do not implement the Link Test function. This interoperability is possible because the bIMR device will not allow the TP port to enter link fail state, even if no Link Test pulses or data packets are being received. Note however that the bIMR chip will always transmit Link Test pulses to all TP ports regardless of whether or not the port is enabled, partitioned, in link fail state, or has its Link Test receive function disabled.

### Polarity Reversal

The TP ports have the optional (programmable) ability to invert (correct) the polarity of the received data if the TP port senses that the received data packet waveform polarity is reversed due to a wiring error. This receive circuitry polarity correction allows subsequent packets to be repeated with correct polarity. This function is executed once following reset or link fail, and has a programmable enable/disable option on a port-by-port basis. This function is disabled upon reset and can be enabled via the bIMR chip Management Port.

### Reset

The bIMR device enters reset state when the  $\overline{\text{RST}}$  pin is driven LOW. After the initial application of power, the  $\overline{\text{RST}}$  pin must be held LOW for a minimum of 150  $\mu\text{s}$  (3000 X1 clock cycles). If the  $\overline{\text{RST}}$  pin is subsequently asserted while power is maintained to the bIMR device, a reset duration of only 4  $\mu\text{s}$  is required. The bIMR chip continues to be in the reset state for 10 X1 clocks (0.5  $\mu\text{s}$ ) following the rising edge of  $\overline{\text{RST}}$ . During reset, the output signals are placed in their inactive states. This means that all analog signals are placed in their idle states, bidirectional signals are not driven, active LOW signals are driven HIGH, and all active HIGH signals and the STR pin are driven LOW.

An internal circuit ensures that a minimum reset pulse is generated for all internal circuits. For a  $\overline{\text{RST}}$  input with a slow rising edge, the input buffer threshold may be crossed several times due to ripple on the input waveform.

In a multiple bIMR chip repeater the  $\overline{\text{RST}}$  signal should be applied simultaneously to all bIMR devices and should be synchronized to the external X1 clock. Reset synchronization is also required when accessing the PAM (Port Activity Monitor).

The SI signal should be held HIGH for at least 500 ns following the rising edge of  $\overline{\text{RST}}$ .

Table 1 summarizes the state of the bIMR chip following reset.

**Table 1. bIMR Chip After Reset**

Function	State After Reset	Pull Up/Pull Down
Active LOW outputs	HIGH	No
Active HIGH outputs	LOW	No
SO Output	HIGH	No
DAT, JAM	HI-IMPEDANCE	Either
STR	LOW	No
Transmitters (TP and AUI)	IDLE	No
Receivers (TP and AUI)	ENABLED	Terminated
AUI Partitioning/Reconnection Algorithm	STANDARD ALGORITHM	N/A
TP Port Partitioning/Reconnection Algorithm	STANDARD ALGORITHM	N/A
Link Test Function for TP Ports	ENABLED, TP PORTS IN LINK FAIL	N/A
Automatic Receiver Polarity Reversal Function	DISABLED	N/A

## Expansion Port

The bIMR chip Expansion Port is comprised of five pins; two are bi-directional signals (DAT and JAM), two are input signals ( $\overline{ACK}$  and  $\overline{COL}$ ), and one is an output signal ( $\overline{REQ}$ ). These signals are used when a multiple-bIMR device repeater application is employed. In this configuration, all bIMR chips must be clocked synchronously with a common clock connected to the X1 inputs of all bIMR devices. Reset needs to be synchronized to X1 clock.

The bIMR device expansion scheme allows the use of multiple bIMR chips in a single board repeater or a modular multipoint repeater with a backplane architecture. The DAT pin is a bidirectional I/O pin which can be used to transfer data between the bIMR devices in a multiple-bIMR chip design. The data sent over the DAT line is in NRZ format and is synchronized to the common clock. The JAM pin is another bidirectional I/O pin that is used by the active bIMR chip to communicate its internal status to the remaining (inactive) bIMR devices. When JAM is asserted HIGH, it indicates that the active bIMR device has detected a collision condition and is generating Jam Sequence. During this time when JAM is asserted HIGH, the DAT line is used to indicate whether the active bIMR chip is detecting collision on one port only or on more than one port. When DAT is driven HIGH by the bIMR chip (while JAM is asserted by the bIMR chip), then the active bIMR device is detecting a collision condition on one port only. This 'one-port-left' signaling is necessary for a multiple-bIMR device repeater to function correctly as a single multipoint repeater unit. The bIMR chip also signals the 'one port left' collision condition in the event of a runt packet or collision fragment; this signal will continue for one expansion port bus cycle (100 ns) before deasserting  $\overline{REQ}$ .

The arbitration for access to the bussed bi-directional signals (DAT and JAM) is provided by one output ( $\overline{REQ}$ ) and two inputs ( $\overline{ACK}$  and  $\overline{COL}$ ). The bIMR chip asserts the  $\overline{REQ}$  pin to indicate that it is active and wishes to drive the DAT and JAM pins. An external arbiter senses the  $\overline{REQ}$  lines from all the bIMR devices and asserts the  $\overline{ACK}$  line when one and only one bIMR chip is asserting its  $\overline{REQ}$  line. If more than one bIMR chip is asserting its  $\overline{REQ}$  line, the arbiter must assert the  $\overline{COL}$  signal, indicating that more than one bIMR device is active. More

than one active bIMR device at a time constitutes a collision condition, and all bIMR devices are notified of this occurrence via the  $\overline{COL}$  line of the Expansion Port.

Note that a transition from multiple bIMR devices arbitrating for the DAT and JAM pins (with  $\overline{COL}$  asserted,  $\overline{ACK}$  deasserted) to a condition when only one bIMR chip is arbitrating for the DAT and JAM pins (with  $\overline{ACK}$  asserted,  $\overline{COL}$  deasserted) involves one expansion port bus cycle (100 ns). During this transitional bus cycle,  $\overline{COL}$  is deasserted,  $\overline{ACK}$  is asserted, and the DAT and JAM pins are not driven. However, each bIMR device will remain in the collision state (transmitting jam sequence) during this transitional bus cycle. In subsequent expansion port bus cycles ( $\overline{REQ}$  and  $\overline{ACK}$  still asserted), the bIMR devices will return to the 'master and slaves' condition where only one bIMR device is active (with collision) and is driving the DAT and JAM pins. An understanding of this sequence is crucial if non-bIMR devices (such as an Ethernet controller) are connected to the expansion bus. Specifically, the last device to back off of the Expansion Port after a multi-bIMR chip collision must assert the JAM line until it too drops its request for the Expansion Port.

## External Arbiter

A simple arbitration scheme is required when multiple bIMR devices are connected together to increase the total number of repeater ports. The arbiter should have one input ( $\overline{REQ1} \dots \overline{REQn}$ ) for each of the n bIMR devices to be used, and two global outputs ( $\overline{COL}$  and  $\overline{ACK}$ ). This function is easily implemented in a PAL<sup>®</sup> device, with the following logic equations:

$$\begin{aligned}
 \overline{ACK} &= \overline{REQ1} \ \& \ \overline{REQ2} \ \& \ \overline{REQ3} \ \& \ \dots \ \overline{REQn} \\
 &+ \overline{REQ1} \ \& \ REQ2 \ \& \ REQ3 \ \& \ \dots \ REQn \\
 &\quad \cdot \\
 &\quad \cdot \\
 &\quad \cdot \\
 &+ \overline{REQ1} \ \& \ \overline{REQ2} \ \& \ \overline{REQ3} \ \& \ \dots \ REQn \\
 \overline{COL} &= \overline{ACK} \ \& \ (REQ1 + REQ2 + REQ3 + \dots REQn)
 \end{aligned}$$

Above equations are in positive logic, i.e., a variable is true when asserted.

A single PALCE16V8 will perform the arbitration function for a repeater based on several bIMR devices.

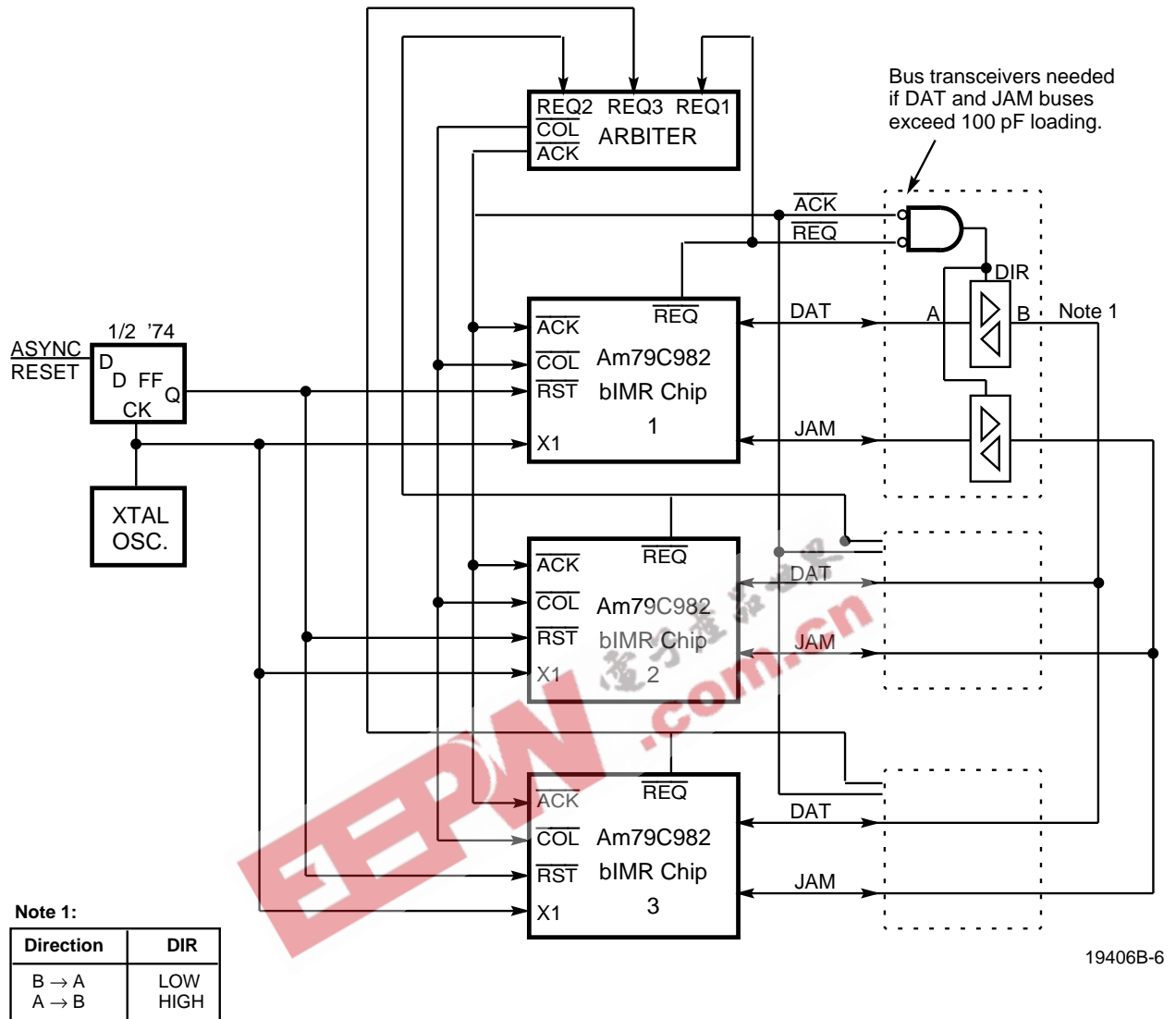

Figure 1. Multiple bIMR Devices

### Modular Repeater Design

The expansion port of the bIMR chip also allows for modular expansion. By sharing the arbitration duties between a backplane bus architecture and several separate repeater modules one can build an expandable

repeater based on modular 'plug-in' cards. Each repeater module performs the local arbitration function for the bIMR devices on that module, and provides signals to the backplane for use by a global arbiter.

### Implementing a 12-Port Unmanaged Hub

Both bIMR4 and bIMR8 chips have an expansion bus that allows multiple devices to be connected together, allowing high port count repeaters to be designed. The operation of the expansion bus is identical for the bIMR4 and bIMR8. Minimum Mode is available in both bIMR4 and bIMR8 devices. This mode facilitates the implementation of the LED display for unmanaged hub.

Figure 2 shows a simple example where one four port bIMR device and one eight port bIMR device are connected together to form one twelve port logical unmanaged repeater. As both devices are on the same board the arbiter function can be local, and the bus transceivers shown at right in Figure 1 are not

necessary due to the low bus loading in this example. In this case, the arbiter simply asserts  $\overline{ACK}$  if one  $\overline{REQ}$  signal is asserted and  $\overline{COL}$  if both  $\overline{REQ}$  signals are asserted. The arbiter does not assert either signal if neither  $\overline{REQ}$  is asserted. Note that both  $\overline{ACK}$  and  $\overline{COL}$  are logic low when asserted.

The D type flip flop is used to synchronize the reset signals to both bIMR devices in order to ensure that the internal 10 MHz clocks of these devices are in phase.

More complex repeaters, including stackable hubs, may be built using the bIMR family. In these cases, the bus transceivers may be necessary and the arbitration may be distributed throughout the system.

EEPW 电子产品世界  
.com.cn

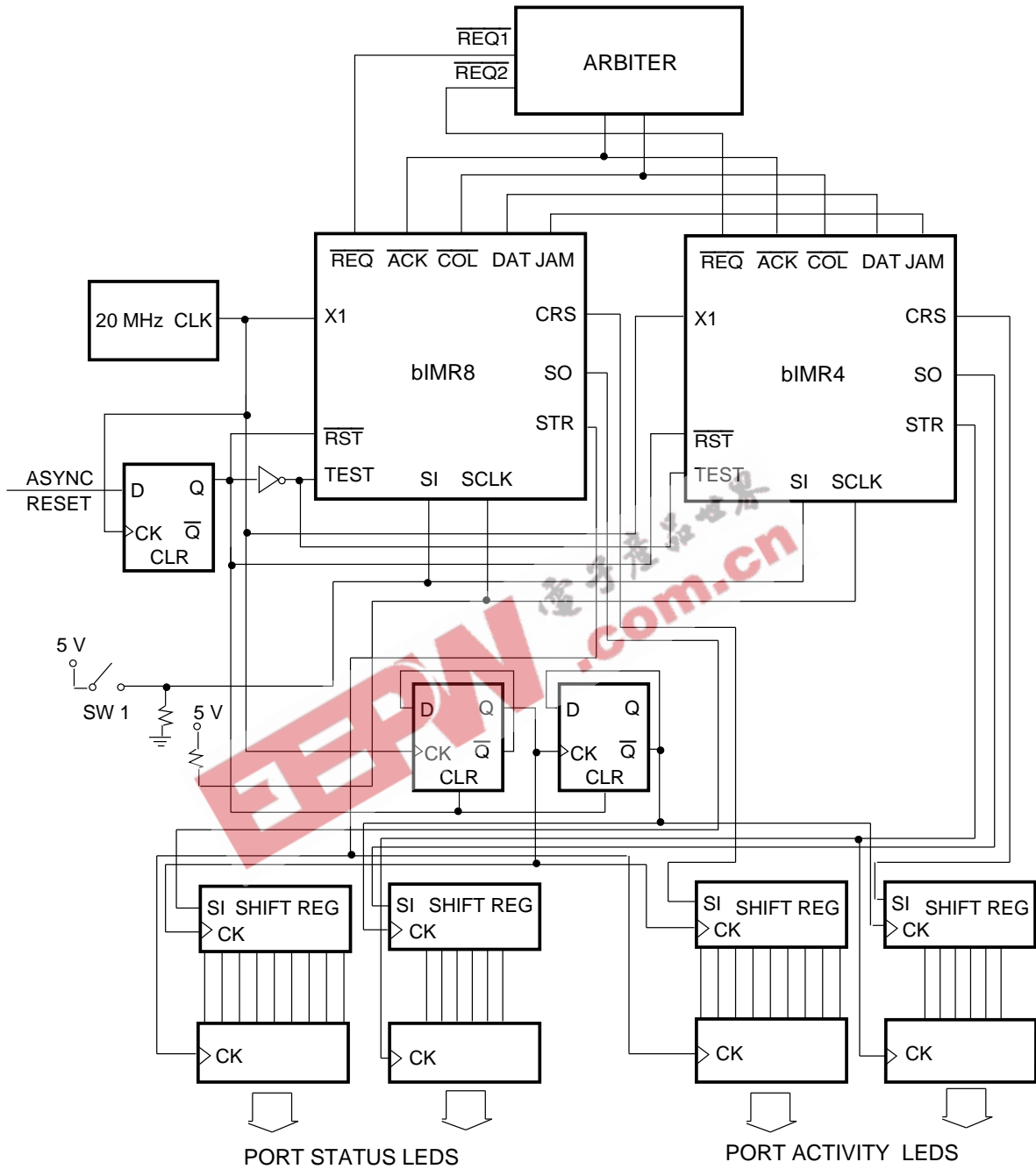

19406B-7

**Notes:**

1. Both bIMR8 and bIMR4 devices are used in Minimum Mode.
2. The information displayed by Port Status LEDs is selected by SW1. In this design, only Link Status and Port Partition Status can be selected. Users can implement more display options by changing the state of the SCLK input (see the section on Minimum Mode for detail).
3. The Polarity correction feature is shown disabled since the SI is high at reset. Users can enable this feature by keeping the SI input low upon reset.

**Figure 2. Implementing a 12-Port Unmanaged Hub using a bIMR8 and a bIMR4**

### Management Port

The BMR device management functions are enabled when the TEST pin is tied LOW. The management commands are byte oriented data and are input serially on the SI pin. Any responses generated during execution of a management command are output serially in a byte-oriented format by the BMR device on the SO pin. Both the input and output data streams are clocked with the rising edge of the SCLK pin. The serial command data stream and any associated results data stream are structured in a manner similar to the RS232 serial data format, i.e., one Start Bit followed by eight Data Bits.

The externally generated clock at the SCLK pin can be either a free running clock synchronized to the input bit patterns or a series of individual transitions meeting the

setup and hold times with respect to the input bit pattern. If the latter method is used, it is to be noted that 20 SCLK clock transitions are required for proper execution of management commands that produce SO data, and that 14 SCLK clock transitions are needed to execute management commands that do not produce SO data.

### Management Commands

The following section details the operation of each management command available in the BMR chip. In all cases, the individual bits in each command byte are shown with the MSB on the left and the LSB on the right. Data bytes are received and transmitted LSB first and MSB last. See Table 2 for a summary of the management commands.

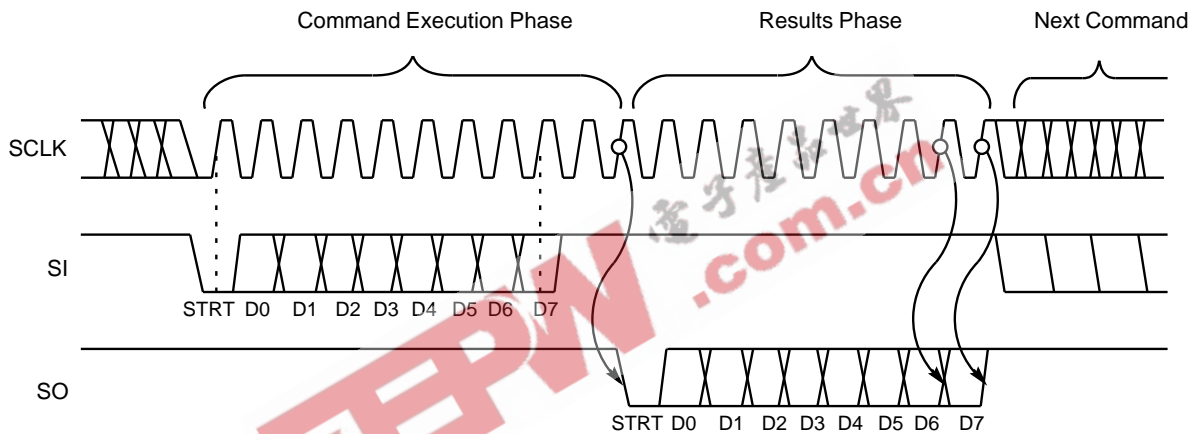

19406B-8

Management Command/Response Timing

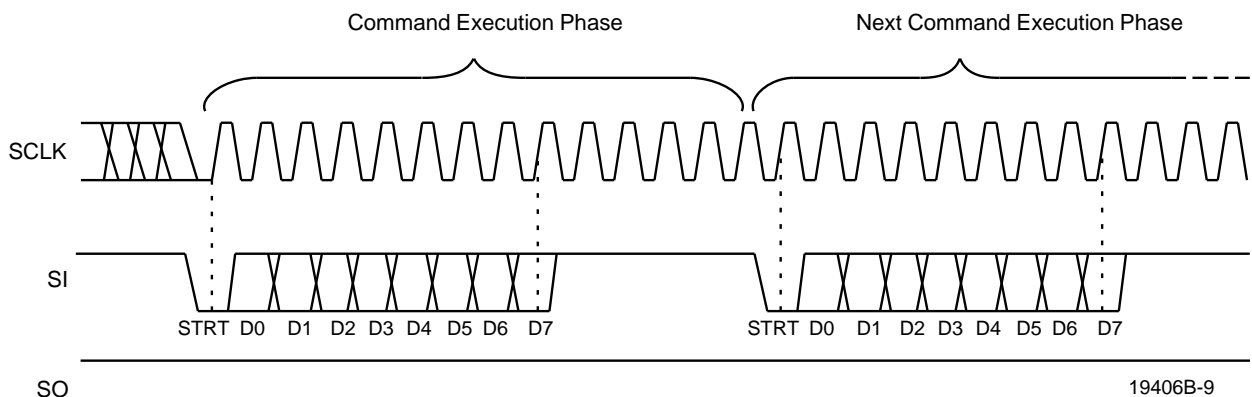

19406B-9

Management Command Timing with No Response



Table 2. Management Port Command Summary

Commands	SI Data	SO Data
<b>Set (Write) Opcodes</b>		
bIMR Chip Programmable Options	0000 10SA	
Alternate AUI Partitioning Algorithm	0001 1111	
Alternate TP Partitioning Algorithm	0001 0000	
AUI Port Disable	0010 1111	
AUI Port Enable	0011 1111	
TP Port Disable	0010 0### (note 2)	
TP Port Enable	0011 0###	
Disable Link Test Function (per TP port)	0100 0###	
Enable Link Test Function (per TP port)	0101 0###	
Disable Automatic Receiver Polarity Reversal (per TP port)	0110 0###	
Enable Automatic Receiver Polarity Reversal (per TP port)	0111 0###	
<b>Get (Read) Opcodes</b>		
AUI Port Status (B, S, L Cleared)	1000 1111	PBSL 0000
TP Port Partitioning Status	1000 0000	C7...C0 (bIMR8), C3...C0 (bIMR4)
Bit Rate Status of TP ports	1010 0000	E7...E0 (bIMR8), E3...E0 (bIMR4)
Link Test Status of TP ports	1101 0000	L7...L0 (bIMR8), L3...L0 (bIMR4)
Receive Polarity Status of all TP ports	1110 0000	P7...P0 (bIMR8), P3...P0 (bIMR4)
MJLP Status	1111 0000	M000 0000
Version	1111 1111	XXXX 0101
AUI Port Status (S, L Cleared)	1000 1011	PBSL 0000
AUI Port Status (B Cleared)	1000 1101	PBSL 0000
AUI Port Status (None Cleared)	1000 1001	PBSL 0000

**Notes:**

1. Unused opcodes are reserved for future use.
2. Select code for the twisted pair ports (TP0 to TP7).

###	bIMR8	bIMR4
000	TP0	—
001	TP1	TP0
010	TP2	—
011	TP3	TP1
100	TP4	—
101	TP5	TP2
110	TP6	—
111	TP7	TP3

## SET (Write) Opcodes

### bIMR Chip Programmable Options

SI data: 0000 10SA

SO data: None

bIMR Chip Programmable Options can be enabled (disabled) by setting (resetting) the appropriate bit in the command string. The two programmable bits are: **S**—AUI SQE Test Mask, and **A**—Alternative Port Activity Monitor (PAM) Function. These options can be enabled (disabled) by setting (resetting) the appropriate bit in the command string.

#### **S**—AUI SQE Test Mask

Setting this bit allows the bIMR chip to ignore activity on the CI signal pair, in the SQE Test Window, following a transmission on the AUI port. This event occurs when the attached MAU has the SQE Test option enabled, therefore generating a burst of CI activity following every transmission. This is interpreted by the bIMR device as a collision, causing the bIMR device to generate a full Jam pattern. Although the MAU attached to a repeater is required not to have its SQE test function active, this is a common installation error, causing difficulty in diagnosing network throughput problems.

The SQE Test Window, as defined by the IEEE 802.3 (Section 7.2.2.2.4), is from 6-bit times to 34-bit times (0.6  $\mu$ s to 3.4  $\mu$ s). This includes delay introduced by a 50 m AUI. CI activity that occurs outside this window is not ignored and is treated as true collision.

Note that enabling this function does not prevent the reporting of this condition by the bIMR device and the two functions operate independently.

#### **A**—Alternative Port Activity Monitor (PAM) Function

Setting the Alternative Port Activity Monitor Function allows the PAM function to be altered such that the Carrier Sense data is presented unmodified. In default operation the PAM output (Carrier Sense bits in the CRS bit

stream) are masked if the port is either disabled or partitioned. This does not allow the Repeater Management software to sense activity on all segments at all times. The ability to monitor partitioned or disabled ports allows fault tolerance to be built into the Repeater Management software.

#### Alternate AUI Port Partitioning Algorithm

SI data: 00011111

SO data: None

The AUI port Partitioning/Reconnection scheme can be programmed for the alternate (transmit only) reconnection algorithm by invoking this command. To return the AUI back to the standard (transmit or receive) reconnection algorithm, it is necessary to reset the bIMR device. Standard partitioning algorithm is selected upon reset.

#### Alternate TP Ports Partitioning Algorithm

SI data: 00010000

SO data: None

The TP ports Partitioning/Reconnection scheme can be programmed for the alternate (transmit only) reconnection algorithm by invoking this command. All TP ports are affected as a group by this command. To return the TP ports back to the standard (transmit or receive) reconnection algorithm, it is necessary to reset the bIMR device. The standard partitioning algorithm is selected upon reset.

#### AUI Port Disable

SI data: 00101111

SO data: None

The AUI port will be disabled upon receiving this command. Subsequently, the bIMR chip will ignore all inputs (Carrier Sense and SQE) appearing at the AUI port and will not transmit any data or Jam Sequence on the AUI port. Issuing this command will also cause the AUI port to have its internal partitioning state machine forced to its idle state. Therefore, a Partitioned Port may be reconnected by first disabling and then re-enabling the port.

**AUI Port Enable**

SI data: 00111111  
SO data: None

This command enables a previously disabled AUI port. Note that a partitioned AUI port may be reconnected by first disabling (AUI Port Disable Command) and then re-enabling the port with this command.

All ports are enabled upon reset.

**TP Port Disable**

SI data: 00100###  
SO data: None  
(### selects TP port number,  
see note 2 on page 17)

The TP port designated in the command byte will be disabled upon receiving this command. Subsequently, the bIMR device will ignore all inputs appearing at the disabled port's receive pins and will not transmit any data or JAM Sequence on that port's transmit pins. Issuing this command will also cause a TP port to have its partitioning state machine returned to its Idle State (Port Reconnected). Therefore, a partitioned port may be reconnected by first disabling and then re-enabling the port. The disabled port will continue to report correct Link Test Status.

**TP Port Enable**

SI data: 00110###  
SO data: None  
(### selects TP port number,  
see note 2 on page 17)

This command enables a previously disabled TP port. Re-enabling a disabled port causes the port to be placed into Link Test Fail state. This ensures that packet fragments received on the port are not repeated to the rest of the network. Note that to force a TP port into the Link Fail state and/or to reconnect a partitioned TP port, the port should first be disabled (TP Port Disable Command) and then re-enabled with this command. All ports are enabled upon reset.

**Disable Link Test Function of a TP Port**

SI data: 01000###  
SO data: None  
(### selects TP port number,  
see note 2 on page 17)

This command disables the Link Test Function at the TP port designated in the command byte, i.e., the TP port will no longer be disconnected due to Link Fail. A TP port which has its Link Test Function disabled will continue to transmit Link Test Pulses. If a twisted pair port has Link Test disabled, then reading the Link Test Status indicates it being in Link Test Pass.

**Enable Link Test Function of a TP Port**

SI data: 01010###  
SO data: None  
(### selects TP port number,  
see note 2 on page 17)

This command re-enables the Link Test Function in the TP port designated in the command byte. This command executes only if the designated TP port has had the Link Test Function disabled by the Disable Link Test Function command. Otherwise, the command is ignored. Link Test is enabled upon reset.

**Disable Automatic Receiver Polarity Reversal**

SI data: 01100###  
SO data: None  
(### selects TP port number,  
see note 2 on page 17)

This command disables the Automatic Receiver Polarity Reversal Function for the TP port designated in the command byte. If this function is disabled on a TP port with reverse polarity (due to a wiring error), then the TP port will fail Link Test due to the reversed polarity of the Link Pulses. If the Link Test Function is also disabled on the TP port, then the received reversed polarity packets would be repeated to all other network ports in the bIMR chip as inverted data. Automatic Polarity reversal is disabled upon reset.

**Enable Automatic Receiver Polarity Reversal**

SI data: 01110###  
SO data: None  
(### selects TP port number,  
see note 2 on page 17)

This command enables the Automatic Receiver Polarity Reversal Function for the TP port designated in the command byte. If enabled in a TP port, the bIMR chip will automatically invert the polarity of that TP port's receiver circuitry if the TP port is detected as having reversed polarity (due to a wiring error). After reversing the receiver polarity, the TP port could then receive subsequent (reverse polarity) packets correctly.

**GET (Read) Opcodes****AUI Port Status**

SI data: 10001111  
SO data: PBSL0000

The combined AUI status allows a single instruction to be used for monitoring AUI port. The four status bits reported are:

- P Partitioning Status. This bit is 0 if the AUI port is partitioned and 1 if connected.

- B Bit Rate Error. This bit is set to 1 if there has been an instance of FIFO Overflow or Underflow, caused by data received at the AUI port. This bit is cleared when the status is read.
- S SQE Test Status. This bit is set to 1 if SQE Test is detected by the bIMR chip. This bit is cleared when the status is read. A MAU attached to a repeater must have SQE Test disabled. This bit is set even if the AUI port is disabled or partitioned.
- L Loop Back Error. The MAU attached to the AUI is required to loopback data transmitted to DO onto the DI circuit. If loopback carrier is not detected by the bIMR device, then this bit is set to 1 to report this condition. This bit is cleared when the status is read. For a repeater this is the only indication of a broken or missing MAU.

**TP Port Partitioning Status**

SI data: 10000000  
 SO data: P<sub>7</sub>.....P<sub>0</sub> (bIMR8)  
 SO data: P<sub>3</sub> X P<sub>2</sub> X P<sub>1</sub> X P<sub>0</sub> (bIMR4)  
 X = don't care

P<sub>n</sub> = 0 TP port n partitioned  
 P<sub>n</sub> = 1 TP port n connected

The partitioning Status of all four or eight TP ports are accessed by this command. If a port is disabled, reading it partitioning status will indicate that it is connected.

**Bit Rate Error Status of TP Ports**

SI data: 10100000  
 SO data: E<sub>7</sub>.....E<sub>0</sub> (bIMR8)  
 SO data: E<sub>3</sub> X E<sub>2</sub> X E<sub>1</sub> X E<sub>0</sub> (bIMR4)  
 X = don't care

This allows a single command to be used to report Bit Rate Error condition (FIFO Overflow or Underflow) of all Twisted Pair ports. The 8 bits (4 bits) of the output pattern correspond to each of the 8 TP (4 TP) ports, with least significant bit corresponding to port 0.

The status bit for a port is set to 1 if there has been an instance when data received from that port has caused a FIFO error.

All status bits stay set until the status is read.

**Link Test Status of TP Ports**

SI data: 11010000  
 SO data: L<sub>7</sub>.....L<sub>0</sub> (bIMR8)  
 SO data: L<sub>3</sub> X L<sub>2</sub> X L<sub>1</sub> X L<sub>0</sub> (bIMR4)  
 X = don't care

L<sub>n</sub> = 0 TP Port n in Link Test Fail  
 L<sub>n</sub> = 1 TP Port n in Link Test Pass

The Link Test Status of all eight (four) TP ports are accessed by this command. A disabled port continues to report correct Link Test Status. Re-enabling a disabled port causes the port to be placed into Link Test Fail state. This ensures that packet fragments received on the port are not repeated to the rest of the network.

**Receive Polarity Status of TP Ports**

SI data: 11100000  
 SO data: P<sub>7</sub>.....P<sub>0</sub> (bIMR8)  
 SO data: P<sub>3</sub> X P<sub>2</sub> X P<sub>1</sub> X P<sub>0</sub> (bIMR4)  
 X = don't care

P<sub>n</sub> = 0 TP Port n Polarity Correct  
 P<sub>n</sub> = 1 TP Port n Polarity Reversed

The statuses of all eight (four) TP port polarities are accessed with this command. The bIMR chip has the ability to detect and correct reversed polarity on the TP ports' RXD+/- pins. If the polarity is detected as reversed for a TP port, then the bIMR chip will set the appropriate bit in this command's result byte only if the Polarity Reversal Function is enabled for that port.

**MJLP Status**

SI data: 11110000  
 SO data: M00000000

Each bIMR chip contains an independent MAU Jabber Lock Up Protection Timer. The timer is designed to inhibit the bIMR device transmit function, if it has been transmitting continuously for more than 65536 Bit Times. The MJLP Status bit (M) is set to 1 if this happens. This bit remains set and is only cleared when the MJLP status is read by using this command.

**Version**

SI data: 11111111  
 SO data: XXXX0001

This command (1111 1111) can be used to determine the device version.

The bIMR chip responds by the bit pattern: XXXX 0101

### Minimum Mode

The Minimum Mode reconfigures the bIMR device Management Port and is intended to provide support for the low end, non-managed repeaters, requiring minimal external logic to provide LED indication of:

- Twisted Pair Ports Link Status indication and AUI Loopback Status
- Port Partitioning Status
- Twisted Pair Ports Receiver Polarity Status and AUI SQE Test Error Status
- Port Bit Rate Error Status

The Minimum Mode is selected by controlling the state of the TEST pin while  $\overline{RST}$  is asserted. If TEST is High (asserted), while reset is active ( $\overline{RST}$  LOW), then Minimum Mode is selected. The state of SI pin, at the deassertion of the  $\overline{RST}$  signal, determines whether the bIMR chip is to be programmed for Automatic Polarity Detection/Correction.

When entering the Minimum Mode, the TEST input has to be deasserted on the rising edge of reset. A maximum delay of 100 ns is allowed to account for slow devices. The following table summarizes the different modes available.

Test	SI	Functions
0	0	Normal Management Mode
0	1	Normal Management Mode
1	0	Minimum Mode, Receive Polarity Correction disabled
1	1	Minimum Mode, Receive Polarity Correction enabled

In Minimum Mode, the SO pin is used to serially output the various status information based on the state of the SI and SCLK pins. A summary of the status information is provided in the following table.

SCLK	SI	SO Output
0	0	TP Ports Receive Polarity Status + AUI SQE Test Error Status.
0	1	Bit Rate Error (all ports).
1	0	TP Ports Link Status + AUI LoopBack Status
1	1	Port Partitioning Status (all ports)

When SI = 0 then SO will output the related AUI status bits (LoopBack or SQE), followed by the 8 (4) TP status bits (Link or Polarity), starting with the TP port 0.

When SI = 1, the Port Partitioning Status or Port Bit Rate Error Status are scanned out with the AUI first and TP ports following. TP Port 0 is scanned out first.

*Note that the Bit Rate Error, AUI Loopback, and AUI SQE Test Error status bits stay set until they are scanned out.*

The state of SI and SCLK inputs is checked at the end of every STR cycle. The rising edge of the X1 clock, occurring before falling edge of STR, is used to strobe in the state of the SI and SCLK pins.

In this Minimum Mode, the Management Port mode is not active. To exit the Minimum mode, the bIMR device must reset into the normal Management Port mode.

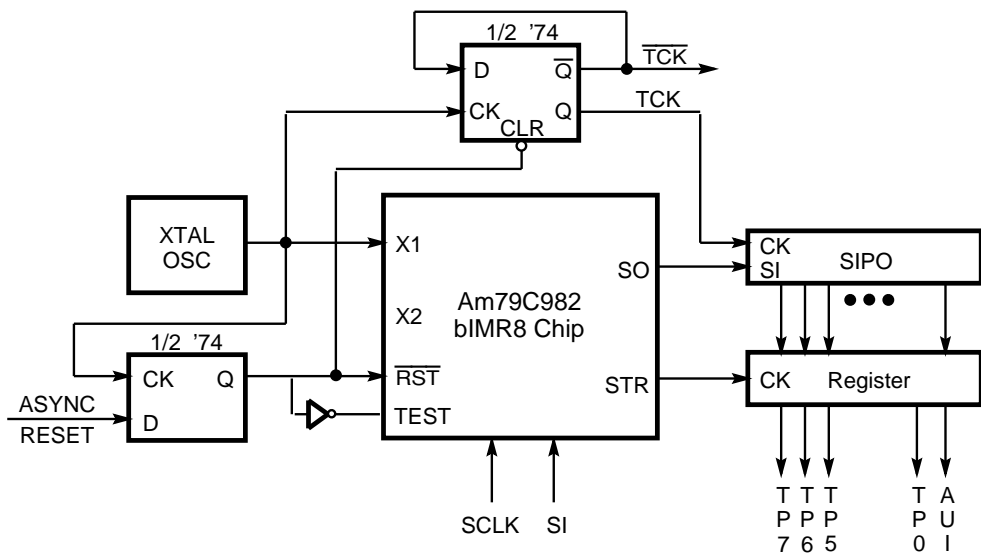

19406B-10

Figure 3. bIMR8 LED Display Design using Minimum Mode

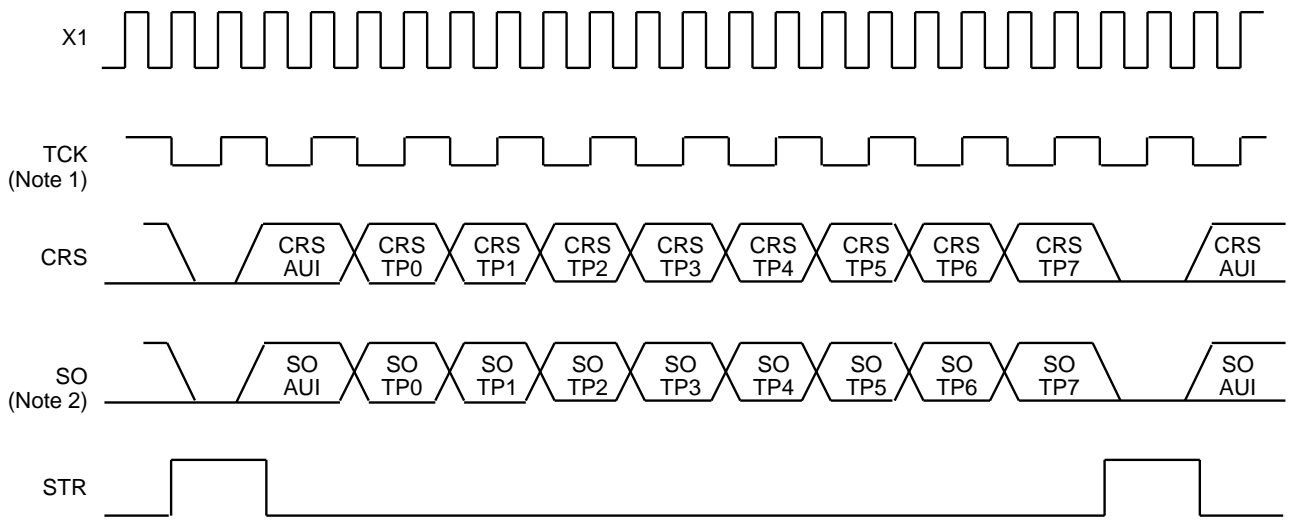

**Notes:**

1. Externally generated signal illustrates internal bIMR chip clock phase relationship.
2. For Minimum Mode

19406B-11

**Figure 4. bIMR8 Management Port Minimum Mode and Port Activity Monitor Signal Relationship**

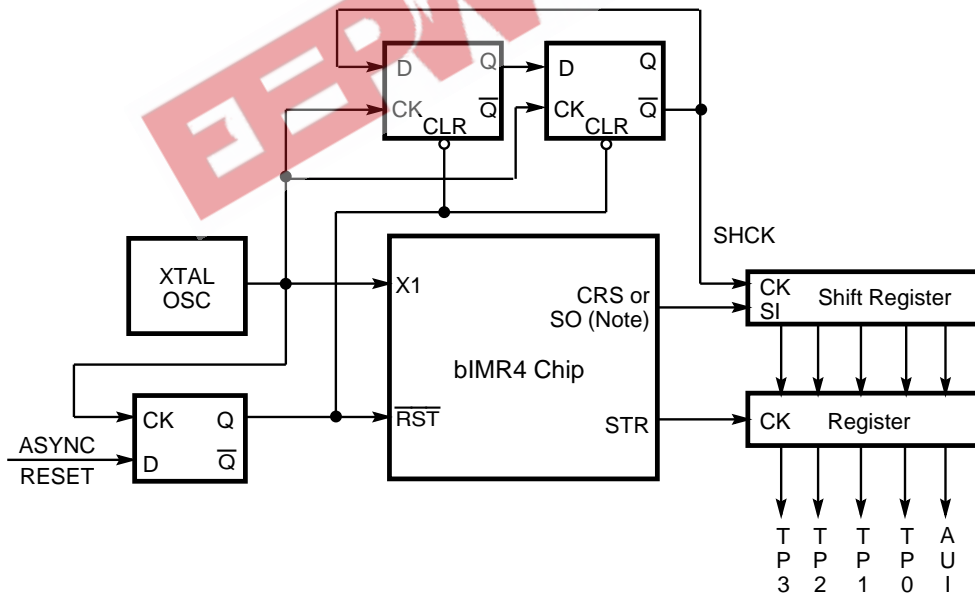

**Note:** When used in minimum mode.

19406B-12

**Figure 5. bIMR4 LED Display Design using Minimum Mode**

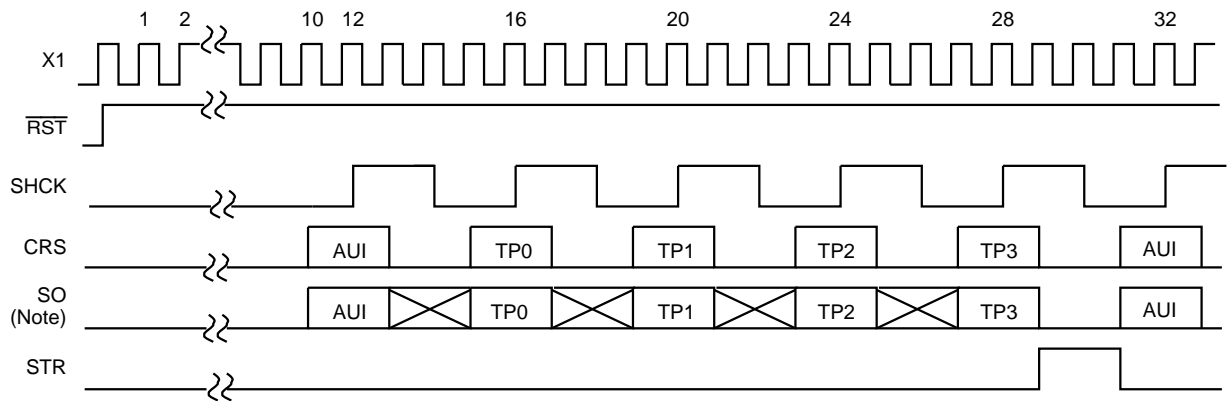

**Note:** When used in minimum mode.

19406B-13

**Figure 6. bIMR4 Management Port Minimum Mode and Port Activity Monitor Signal Relationship**

### Port Activity Monitor

Two pins, CRS and STR, are used to serially output the state of the internal Carrier Sense signals from the AUI and the eight (four) TP ports. This function together with external hardware and/or software can be used to monitor repeater receive and/or collision activity.

The resolution of the CRS signal is 2 ms. The incoming data is sampled repeatedly during each 2 ms period. If any activity occurs (regardless of length) during any 2 ms period, this activity will be latched. At the start of the next 2 ms period, the bIMR device will examine the latches for each port. For any port in which activity occurred, the corresponding bit in the CRS output stream will remain set for the 2 ms period. This means that during any 2 ms time interval the CRS output bit stream represents carrier activity that occurred in the preceding 2 ms period (see Figure 7). During the last

1000 ns of the 2 ms period, the CRS signal is reset to LOW. Figure 7 illustrates this by showing the output of the register in the recommended LED drive circuitry of Figure 8.

The CRS pin is used to indicate carrier sense for all nine ports of the device (five for the Am79C982-4). This pin outputs a ten bit stream that repeats every microsecond. During this period there are ten bit times (100 ns). Each port has a "time slot" in this repeating bit stream (see Figure 4). For example, activity on the AUI port is represented by the state of the CRS pin during the second 100 ns period of the one microsecond cycle.

Because the one microsecond sequence is repeated unchanged for most of the longer 2 ms cycle, any LED driven by the latch and shift register shown in Figure 3 and 5 will remain on for at least 2 ms. This minimizes the need for external pulse stretching logic.

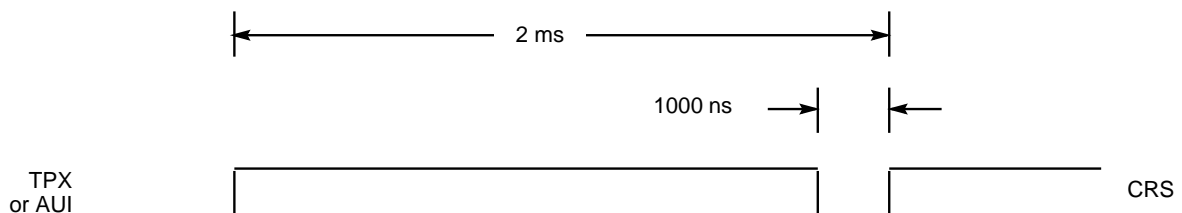

19406B-14

**Figure 7. Carrier Sense Signal Output Corresponding to the States of AUI or Twisted-Pair Port Activity**

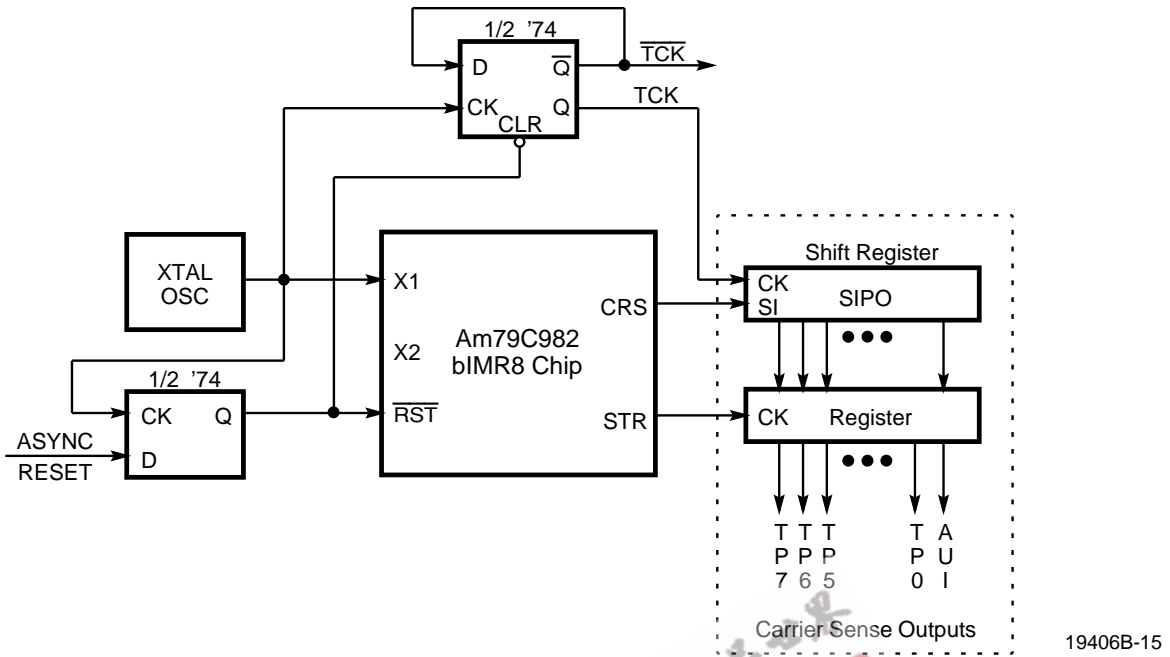

Figure 8a. bIMR8 Port Activity Monitor Implementation



# A 10BASE-T INTERFACE

The table below lists the recommended resistor values and filter and transformer modules for the IMR+ device.  
bIMR+ Device Compatible 10BASE-T Media Interface Modules

Manufacturer	Part #	Package	Description
Bel Fuse	S556-5999-32	16-pin SMD	Transmit and receive filters, transformers and common mode chokes
Bel Fuse	0556-2006-14	10-pin SIL	Transmit and receive filters, transformers and common mode chokes
Bel Fuse	A556-2006-DE	16-pin 0.3" DIL	Transmit and receive filters and transformers.
Bel Fuse	A556-2006-00	16-pin DIL	Transmit filter, transformers and common mode choke. Receive filter and transformer.
Halo Electronics	FS02-101Y4	"Slim SIP"	Transmit and receive filters and transformers.
Halo Electronics	FS12-101Y4	"Slim SIP"	Transmit and receive filters and transformers, transmit common mode choke.
Halo Electronics	FS22-101Y4	"Slim SIP"	Transmit and receive filters, transformers and common mode chokes
Halo Electronics	FD02-101G	16-pin 0.3" DIL	Transmit and receive filters and transformers.
Halo Electronics	FD12-101G	16-pin 0.3" DIL	Transmit and receive filters and transformers, transmit common mode choke.
Halo Electronics	FD22-101G	16-pin 0.3" DIL	Transmit and receive filters, transformers and common mode chokes
Halo Electronics	FD22-101R2	16-pin 0.3" DIL	Termination and equalization resistors, transmit and receive filters, transformers and common mode chokes.
Nano Pulse	5408-37	16-pin SMD	7 pole transmit and receive filters with 1CT:1CT Xfmrs (transmit & receive) and separate common mode choke for each channel.
Nano Pulse	5408-40	9-pin SIP	7 pole transmit and receive filters with 1CT:1CT Xfmrs (transmit & receive) and separate common mode choke for each channel.
Nano Pulse	6612-21	12-pin DIL	7 pole transmit and receive filters with 1CT:1CT Xfmrs (transmit & receive) and separate common mode choke for each channel.
PCA Electronics	EPA1990A	16-pin 0.3" DIL	Transmit and receive filters and transformers.
PCA Electronics	EPA1990AG	SMT device	Transmit and receive filters and transformers.
PCA Electronics	EPA2013D	16-pin 0.3" DIL	Transmit and receive filters and transformers, transmit common mode choke.
PCA Electronics	EPA2013DG	SMT device	Transmit and receive filters and transformers, transmit common mode choke.
Pulse Engineering	78Z034C	16-pin DIL	Transmit and receive filters and transformers, transmit common mode choke.
Pulse Engineering	78Z1120B-01	16-pin DIL	Transmit and receive filters and transformers.
Pulse Engineering	78Z1122B-01	16-pin DIL	Transmit and receive filters, transformers and common mode chokes
Pulse Engineering	PE-68017S	10-pin SIL	Transmit and receive filters, transformers and common mode chokes
Pulse Engineering	PE-68026	16-pin SMT	Transmit and receive filters, transformers and common mode chokes
Pulse Engineering	PE-68056	16-pin SMT	Transmit and receive filters, transformers and common mode chokes
Pulse Engineering	PE-68032	13-pin PCMCIA-SMT	Transmit and receive filters and transformers, transmit common mode choke.
TDK	TLA-3M601-RS	10-pin SIP	Transmit and receive filters and transformers, transmit common mode choke.
TDK	TLA-3M102(-T)	16-pin SMD	Integrated resistors, transmit and receive filters and transformers, transformers and common mode chokes.
TDK	TLA-3M103(-T)	16-pin SMD	Transmit and receive filters and transformers, transmit common mode choke.
Valor Electronics	PT3877	16-pin 0.3" DIL	Transmit and receive filters and transformers.
Valor Electronics	PT3983	8-pin 0.3" DIL	Transmit and receive common mode chokes.
Valor Electronics	FL1012	16-pin 0.3" DIL	Transmit and receive filters and transformers, transmit common mode choke.

# Glossary

## Active Status

In a non-collision state, a bIMR chip is considered active if it is receiving data on any one of its network ports, or is in the process of broadcasting (repeating) FIFO data from a recently completed data reception. In a collision state (the bIMR device is generating Jam Sequence), a bIMR device is considered active if any one or more network ports is receiving data. The bIMR device asserts the  $\overline{\text{REQ}}$  line to indicate that it is active.

## Collision

In a carrier sense multiple access/collision detection (CSMA/CD) network such as Ethernet, only one node can successfully transfer data at any one time. When two or more separate nodes (DTEs or repeaters) are simultaneously transmitting data onto the network, a Collision state exists. In a repeater using one or more bIMR devices, a Collision state exists when more than one network port is receiving data at any instant, or when any one or more network ports receives data while the bIMR device is transmitting (repeating) data, or when the CI+/- pins become active (nominal 10 MHz signal) on the AUI port.

## Jam Sequence

A signal consisting of alternating 1s and 0s that is generated by the bIMR device when a Collision state is detected. This signal is transmitted by the bIMR device to indicate to the network that one or more network ports in the repeater is involved in a collision.

## Network Port

Any of the eight (four) 10BASE-T ports or the AUI port present in the bIMR device (i.e. not the Expansion Port or the Management Port).

## Partitioning

A network port on a repeater has been partitioned if the repeater has internally 'disconnected' it from the repeater due to localized faults that would otherwise bring the entire network down. These faults are generally cable shorts and opens that tend to cause excessive collisions at the network ports. The partitioned network port will be internally re-connected if the network port starts behaving correctly again, usually when successful 'collision-less' transmissions and/or receptions resume.

## Receive Collision

A network port is in a Receive Collision state when it detects collision and is not one of the colliding network 'nodes'. This applies mainly to a non-transmitting AUI port because a remote collision is clearly identified by the presence of a nominal 10 MHz signal on the CI+/- pins. However, any repeater port would be considered to be in a receive collision state if the repeater unit is receiving data from that port as the 'one-port-left' in the collision sequence.

## Transmit Collision

A network port is in a Transmit Collision state when collision occurs while that port is transmitting. On the AUI port, Transmit Collision is indicated by the presence of a nominal 10 MHz signal on the CI+/- pins while the AUI port is transmitting on the DO+/- pins. On a 10BASE-T port, Transmit Collision occurs when incoming data appears on the RXD+/- pins while the 10BASE-T port is transmitting on the TXD+/- and TXP+/- pins.