

**INTRODUCTION**

The KA2410/KA2411 is a bipolar integrated circuit designed for telephone bell replacement.

**FUNCTIONS**

- Two oscillators
- Output amplifier
- Power supply control circuit

**FEATURES**

- Designed for telephone bell replacement
- Low current drain.
- Small size 'MINIDIP' package.
- Adjustable 2-frequency tone.
- Adjustable warbling rate.
- Built-in hysteresis prevents false triggering and rotary dial 'CHIRPS'.
- Extension tone ringer modules.
- Alarms or other alerting devices.
- External triggering or ringer disable. (KA2410)
- Adjustable for reduced initial supply current. (KA2411)

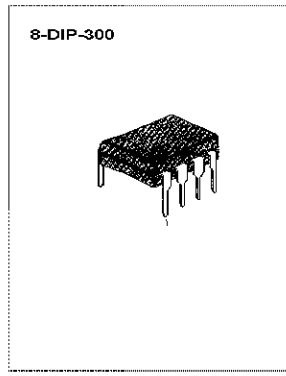

**ORDERING INFORMATION**

Device	Package	Operating Temperature
KA2410	8-DIP-300	- 45 ~ + 65°C
KA2411		

**PIN CONFIGURATION**

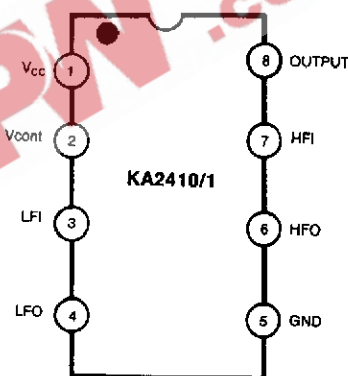

Fig. 1

**ABSOLUTE MAXIMUM RATINGS** ( $T_a = 25^\circ\text{C}$ )

Characteristic	Symbol	Value	Unit
Supply Voltage	$V_{CC}$	30	V
Power Dissipation	$P_D$	400	mW
Operating Temperature	$T_{OPR}$	- 45 ~ 65	$^\circ\text{C}$
Storage Temperature	$T_{STG}$	- 65 ~ 150	$^\circ\text{C}$

**ELECTRICAL CHARACTERISTICS** ( $T_a = 25^\circ\text{C}$ )

(All voltage referenced to GND unless otherwise specified)

Characteristic	Symbol	Test Conditions	Min	Typ	Max	Unit
Operating Voltage	$V_{CC}$	—	—	—	29.0	V
Initiation Voltage <sup>1</sup>	$V_{SI}$	See Fig. 2	17	19	21	V
Initiation Current <sup>1</sup>	$I_{SI}$	KA2411-6.8K-Pin 2 to GND	1.4	2.5	4.2	mA
Sustaining Voltage <sup>2</sup>	$V_{SUS}$	See Fig. 2	9.7	11.0	12.0	V
Sustaining Current <sup>2</sup>	$I_{SUS}$	No Load $V_{CC} = V_{SUS}$ , See Fig. 2	0.7	1.4	2.5	mA
Trigger Voltage <sup>3</sup>	$V_{TRG}$	KA2410 Only $V_{CC} = 15\text{V}$	9.0	10.5	12.0	V
Trigger Current <sup>3</sup>	$I_{TRG}$	KA2410 Only	10.0	20.0	1000 <sup>5</sup>	$\mu\text{A}$
Disable Voltage <sup>4</sup>	$V_{DIS}$	KA2410 Only	—	—	0.8	V
Disable Current <sup>4</sup>	$I_{DIS}$	KA2410 Only	- 40	- 50	—	$\mu\text{A}$
Output Voltage High	$V_{OH}$	$V_{CC} = 21\text{V}$ , $I_b = -15\text{mA}$ Pin 6 = 6V, Pin 7 = GND	17.0	19.0	21.0	V
Output Voltage Low	$V_{OL}$	$V_{CC} = 21\text{V}$ , $I_b = 15\text{mA}$ Pin 6 = GND, Pin 7 = 6V	—	—	1.6	V
Input Current 1 (Pin 3)	$I_{I(PIN 3)}$	Pin 3 = 6V, Pin 4 = GND	—	—	500	nA
Input Current 2 (Pin 7)	$I_{I(PIN 7)}$	Pin 7 = 6V, Pin 6 = GND	—	—	500	nA
High Frequency 1	$f_{H1}$	$R_3 = 191\text{K}$ , $C_3 = 6800\text{pF}$	461	512	563	Hz
High Frequency 2	$f_{H2}$	$R_3 = 191\text{K}$ , $C_3 = 6800\text{pF}$	576	640	704	Hz
Low Frequency	$f_L$	$R_2 = 165\text{K}$ , $C_2 = 0.47\mu\text{F}$	9.0	10	11.0	Hz

• NOTE (see electrical characteristics sheet)

1. Initial supply voltage ( $V_{SI}$ ) is the supply voltage required to start the tone ringer oscillating.
2. Sustaining voltage ( $V_{SUS}$ ) is the supply voltage required to maintain oscillation.
3.  $V_{TR}$  and  $I_{TR}$  are the conditions applied to trigger in to start oscillation for  $V_{SUS} \leq V_{CC} \leq V_{SI}$
4.  $V_{DIS}$  and  $I_{DIS}$  are the conditions applied to trigger in to inhibit oscillation for  $V_{SI} \leq V_{CC}$
5. Trigger current must be limited to this value externally.

GRAPH

KA2410 Supply Current (No Load) Vs. Supply Voltage

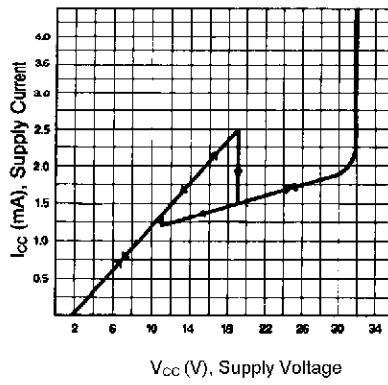

Fig. 2

KA2411 Supply Current (No Load) Vs. Supply Voltage

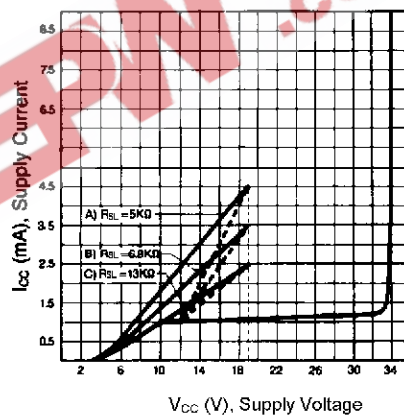

Fig. 3

**APPLICATION INFORMATION**

The application circuit illustrates the use of the KA2410/1 devices in typical telephone or extensive tone ringer applications. The AC ringer signal voltage appears across the TIP and RING inputs of the circuit and is attenuated by capacitor C<sub>1</sub> and resistor R<sub>1</sub>. C<sub>1</sub> also provides isolation from DC voltages (48V) on the exchange line. After full wave rectification by the bridge diode, the waveform is filtered by capacitor C<sub>4</sub> to provide a DC supply for the tone ringer chip. When this voltage exceeds the initiation (V<sub>SI</sub>), oscillation starts. With the components shown, the output frequency chops between 512 Hz (f<sub>H1</sub>) and 640Hz (f<sub>H2</sub>) at a 10Hz (f<sub>L</sub>) rate. The loudspeaker load is coupled through a 1300Ω to 8Ω transformer. The output coupling capacitor C<sub>5</sub> is required with transformer coupled loads. When driving a piezo-ceramic transducer type load, the coupling C<sub>5</sub> and transformer (1300Ω :8Ω) are not required. However, a current limiting resistor is required. The low frequency oscillator oscillates at a rate (f<sub>L</sub>) controlled by an external resistor (R<sub>2</sub>) and capacitor (C<sub>2</sub>). The frequency can be determined using the relation  $f_L = 1/(1.289 R_2 \cdot C_2)$ . The high frequency oscillates at a f<sub>H1</sub>, f<sub>H2</sub> controlled by an external resistor (R<sub>3</sub>) and capacitor (C<sub>3</sub>). The frequency can be determined using the relation  $f_{H1} = 1/(1.504 R_3 \cdot C_3)$  voltage remains constant independent of R<sub>SL</sub>.

Pin 2 of the KA2411 allows connection of an external resistor R<sub>SL</sub>, which is used to program the slope of the supply current vs supply voltage characteristics (see Fig. 3) and hence the supply current up to the initial voltage (V<sub>SI</sub>). This initial voltage remains constant independent of R<sub>SL</sub>.

The supply current drawn prior to triggering varies inversely with R<sub>SL</sub>, decreasing for an increasing value of resistance. Thus, increasing the value of R<sub>SL</sub>, will decrease the amount of AC ringing current required to trigger the device. As such longer subscriber loops are possible since less voltage is dropt per unit length of loop wire due to the lower current level. R<sub>SL</sub> can also be used to compensate for smaller AC coupling capacitors (C<sub>5</sub> on Fig. 5) (higher impedance) to the line which is used to alter the ringer equivalence number of a tone ringer circuit.

The graph in Fig. 3 illustrates the variation of supply current with supply voltage of the KA2411. Three curves are drawn to show the variation of initiation current with R<sub>SL</sub>. Curve B (R<sub>SL</sub> = 6.8kΩ) shows the I-V characteristic for the KA2411 tone ringer. Curve A is a plot with R<sub>SL</sub> < 6.8kΩ and shows an increase in the current drawn up to the initiation voltage V<sub>SI</sub>. After initiation, the I-V characteristic remain unchanged. Curve C illustrates the effect of increasing R<sub>SL</sub> above 6.8kΩ initiation current decreases but is unchanged again after triggering.

**APPLICATION CIRCUIT 1 (KA2410)**

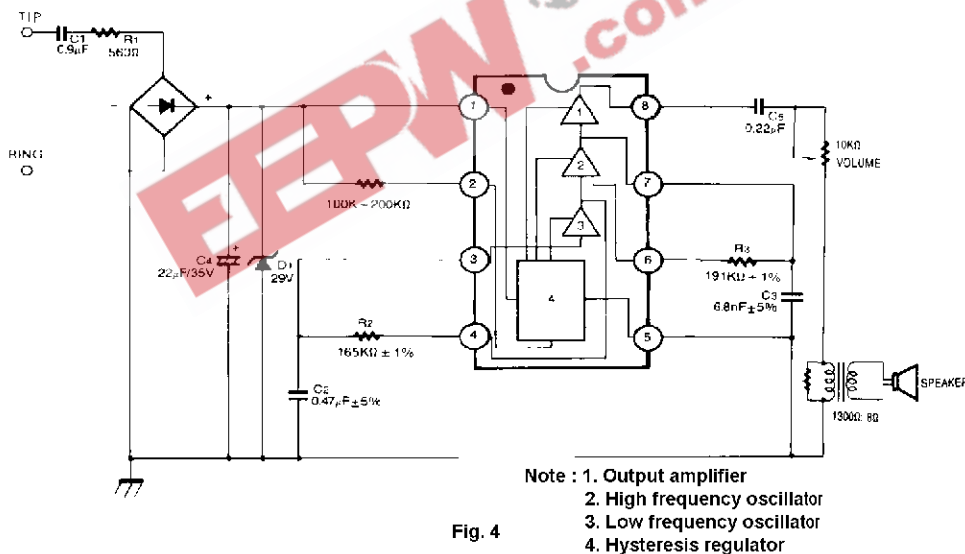

Fig. 4

APPLICATION CIRCUIT 2 (KA2411)

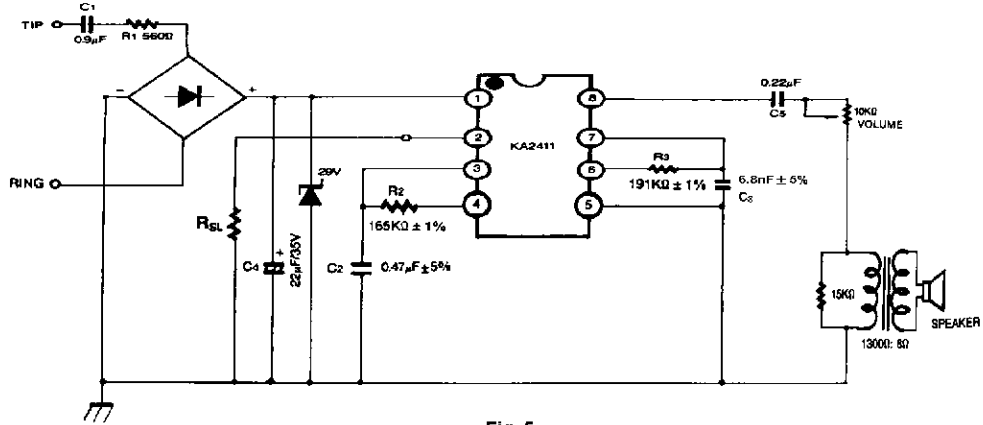

Fig. 5

EQUIVALENT CIRCUIT  
(Pin 2 Input)

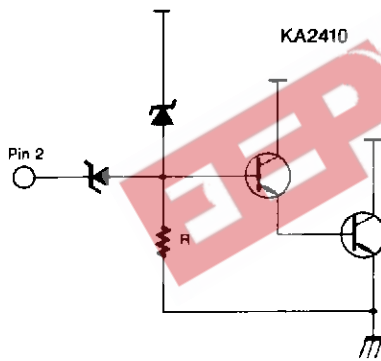

Fig. 6

INHIBITING OSCILLATION

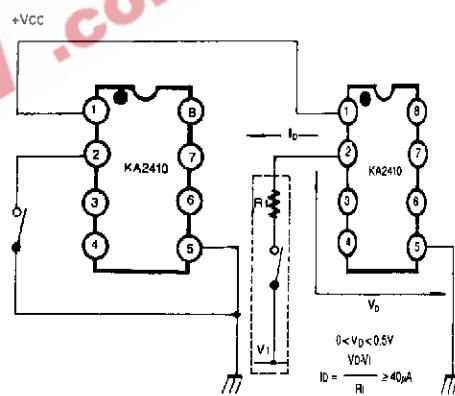

Fig. 7

TRIGGERING THE KA2410 FROM CMOS OR TTL LOGIC

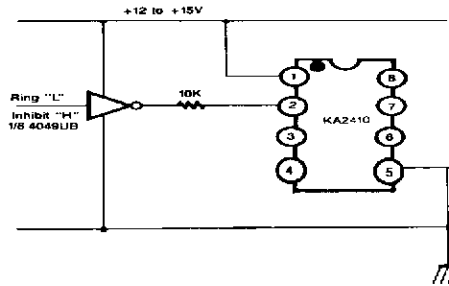

Fig. 8

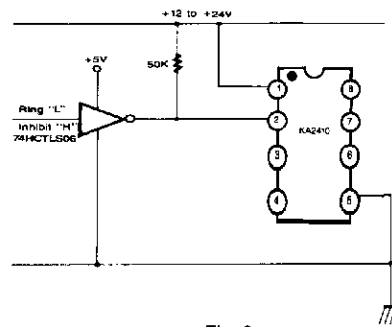

Fig. 9

PROGRAMMING THE KA2410 INITIATION SUPPLY VOLTAGE

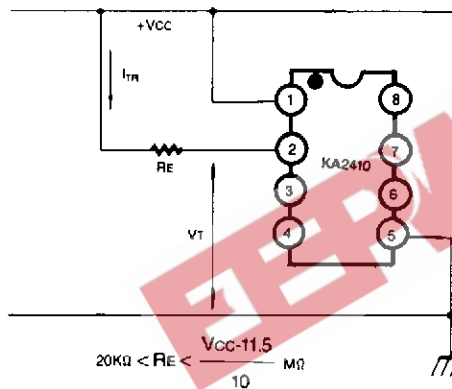

Fig. 10

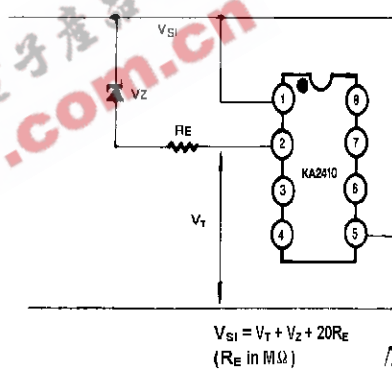

Fig. 11

Dimensions in Millimeters

