

**LOW POWER LOW OFFSET VOLTAGE DUAL COMPARATORS****AZ393****General Description**

The AZ393 series consists of two independent precision voltage comparators with an offset voltage specification as low as 1mV. The input common mode voltage range of these comparators includes ground, even when operated from a single power supply voltage. Operation from split power supplies is also possible and the low power supply current drain is independent of the magnitude of the power supply voltage.

The AZ393 series is designed to directly interface with TTL and CMOS.

The AZ393 series can be widely used in such applications as battery charger, cordless telephone, switching power supply, DC-DC module and PC motherboard.

Features

- Wide supply
 - Voltage range: 2.0V to 18V
 - Single or dual supplies: $\pm 1.0V$ to $\pm 9V$
- Very low supply current drain: 0.4mA
 - independent of supply voltage
- Low input bias current: 25nA
- Low input offset current: $\pm 5nA$
- Low input offset voltage: 1mV
- Input common mode voltage range that includes ground
- Differential input voltage range equal to the power supply voltage
- Low output saturation voltage: 250mV at 4mA
- Open-collector output

Applications

- Battery Charger
- Cordless Telephone
- Switching Power Supply
- DC-DC Module
- PC Motherboard
- Communication Equipment



Figure 1. Package Types of AZ393



LOW POWER LOW OFFSET VOLTAGE DUAL COMPARATORS

AZ393

Pin Configuration

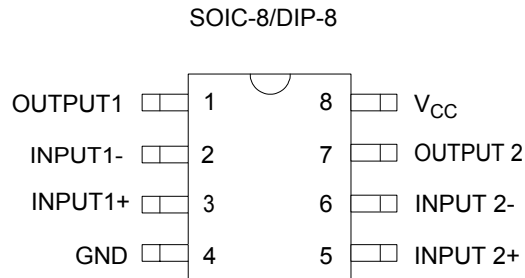

Top View

Figure 2. Pin Configuration of AZ393

Functional Block Diagram

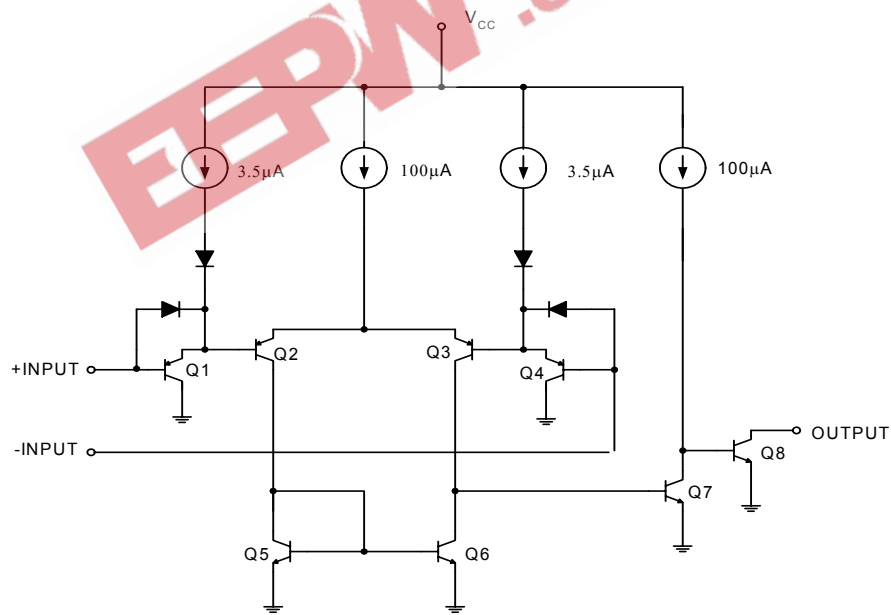

Figure 3. Functional Block Diagram of AZ393

(Each Comparator)

**LOW POWER LOW OFFSET VOLTAGE DUAL COMPARATORS****AZ393****Ordering Information**

Package	Temperature Range	Part Number	Marking ID	Packing Type
SOIC-8	-40°C ~ 85°C	AZ393M	AZ393M	Tube/ Reel
DIP-8		AZ393P	AZ393P	Tube

Absolute Maximum Ratings (Note 1)

(Operation temperature range applies unless otherwise specified.)

Parameter	Symbol	Min	Max	Unit
Supply Voltage	V_{CC}		20	V
Differential Input Voltage	V_{ID}		20	V
Input Voltage	V_{IN}	-0.3	20	V
Input Current ($V_{IN} < -0.3V$)	I_{IN}		50	mA
Power Dissipation	P_D		780	mW
Output Short -Circuit to Ground		Continuous		
Operating Temperature	T_A	-40	85	°C
Storage Temperature	T_{STG}	-65	165	°C
Lead Temperature (Soldering, 10 seconds)	T_{LEAD}		260	°C

Note 1: Stresses greater than those listed under "Absolute Maximum Ratings" may cause permanent damage to the device. These are stress ratings only, and functional operation of the device at these or any other conditions beyond those indicated under "Recommended Operation Ratings" is not implied. Exposure to "Absolute Maximum Ratings" for extended periods may affect device reliability.

Recommended Operation Ratings

Parameter	Min	Max	Unit
Supply Voltage		18	V
Operating Temperature Range	-40	85	°C



LOW POWER LOW OFFSET VOLTAGE DUAL COMPARATORS

AZ393

Electrical Characteristics

$V_{CC} = +5V$, $T_A = 25^\circ C$, unless otherwise specified.

Parameter	Conditions	Min	Typ	Max	Unit
Input Offset Voltage	(Note 2)		1.0	5.0	mV
Input Bias Current	$I_{IN (+)}$ or $I_{IN (-)}$ with output in linear range, $V_{CM} = 0V$, (Note 3)		25	250	nA
Input Offset Current	$I_{IN (+)} - I_{IN (-)}$, $V_{CM} = 0V$		5.0	50	nA
Input Common Mode Voltage Range	$V_{CC} = 15V$, (Note 4)	0		$V_{CC} - 1.5$	V
Supply Current	$R_L = \infty$, $V_{CC} = 5V$		0.4	1.0	mA
	$R_L = \infty$, $V_{CC} = 18V$		1.0	2.5	
Voltage Gain	$R_L \geq 15K\Omega$, $V_{CC} = 8V$, $V_O = 1V$ to $6V$	50	200		V/mV
Large Signal Response Time	$V_{IN} =$ TTL logic swing, $V_{REF} = 1.4V$, $V_{RL} = 5V$, $R_L = 5.1K\Omega$		300		ns
Response Time	$V_{RL} = 5V$, $R_L = 5.1K\Omega$, (Note 5)		1.3		μs
Output Sink Current	$V_{IN (-)} = 1V$, $V_{IN (+)} = 0$, $V_O \leq 1.5V$	6.0	16		mA
Saturation Voltage	$V_{IN (-)} = 1V$, $V_{IN (+)} = 0$, $I_{SINK} \leq 4mA$		250	400	mV
Output Leakage Current	$V_{IN (-)} = 0$, $V_{IN (+)} = 1V$, $V_O = 5V$		0.1		nA

Note 2: At output switch point, $V_O = 1.4V$, $R_S = 0$ with V_{CC} from 5V to 15V, and over the full common-mode range (0V to $V_{CC} - 1.5V$), at $25^\circ C$.

Note 3: The direction of the input current is out of the PNP input stage. This current is essentially constant, independent of the state of the output, so no loading charge exists on the reference of input lines.

Note 4: The input common-mode voltage of either input signal voltage should not be allowed to go negative by more than 0.3V. The upper end of the common-mode voltage range is $V_{CC} - 1.5V$, but either or both inputs can go to +18V without damage, independent of the magnitude of V_{CC} .

Note 5: The response time specified is a 100mV input step with 5mV overdrive. For large overdrive signals 300ns can be obtained.



Typical Characteristics

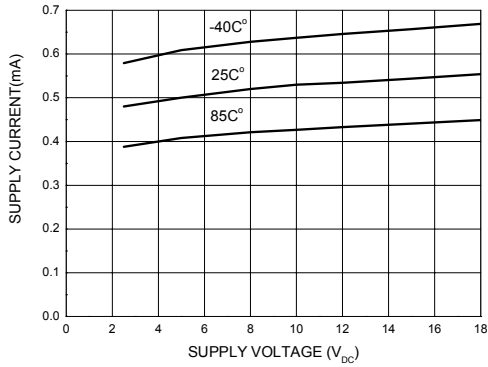

Figure 4. Supply Voltage vs. Supply Current

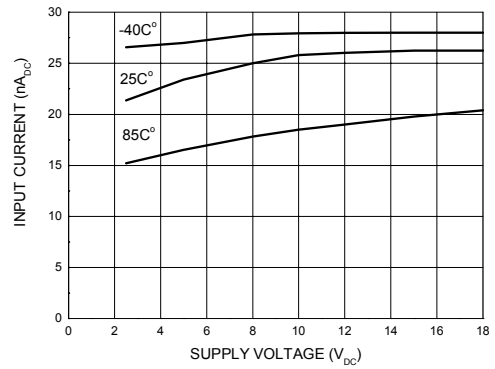

Figure 5. Supply Voltage vs. Input Current

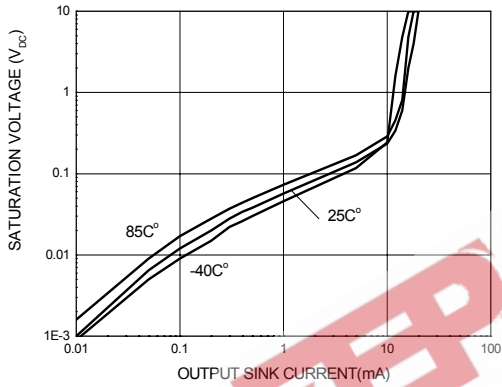

Figure 6. Output Sink Current vs Saturation Voltage

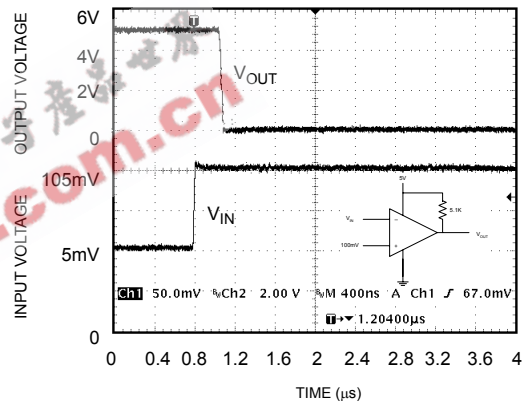

Figure 7. Response Time for 5mV Input Overdrive - Negative Transition

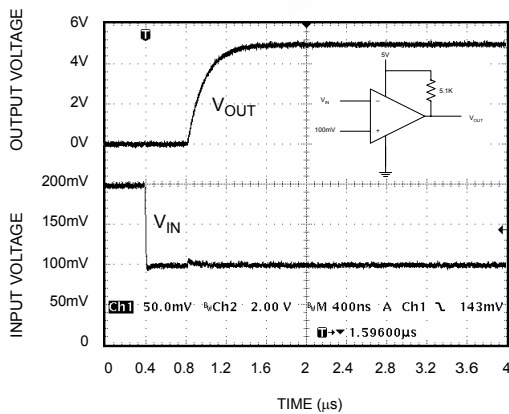

Figure 8. Response Time for 5mV Input Overdrive - Positive Transition



Typical Applications

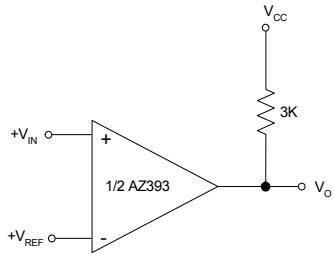

Figure 9. Basic Comparator

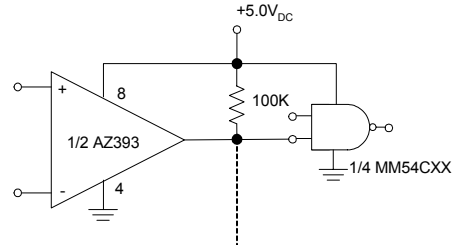

Figure 10. Driving CMOS/TTL

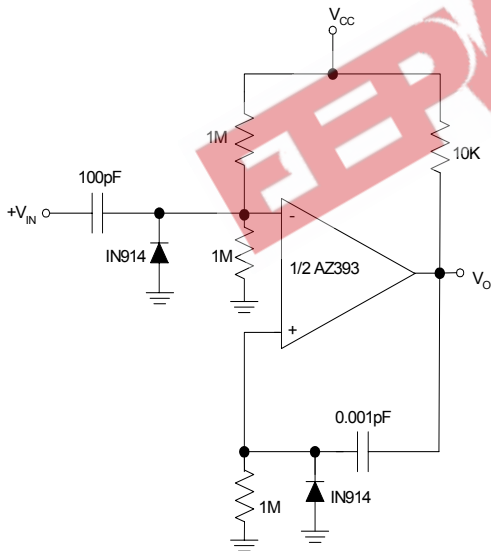

Figure 11. One Shot Multivibrator

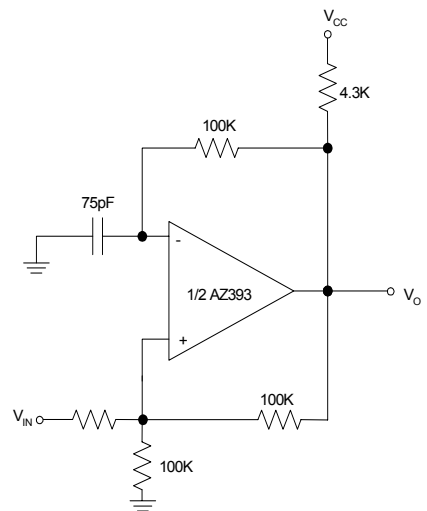

Figure 12. Squarewave Oscillator



LOW POWER LOW OFFSET VOLTAGE DUAL COMPARATORS

AZ393

Mechanical Dimensions

DIP - 8

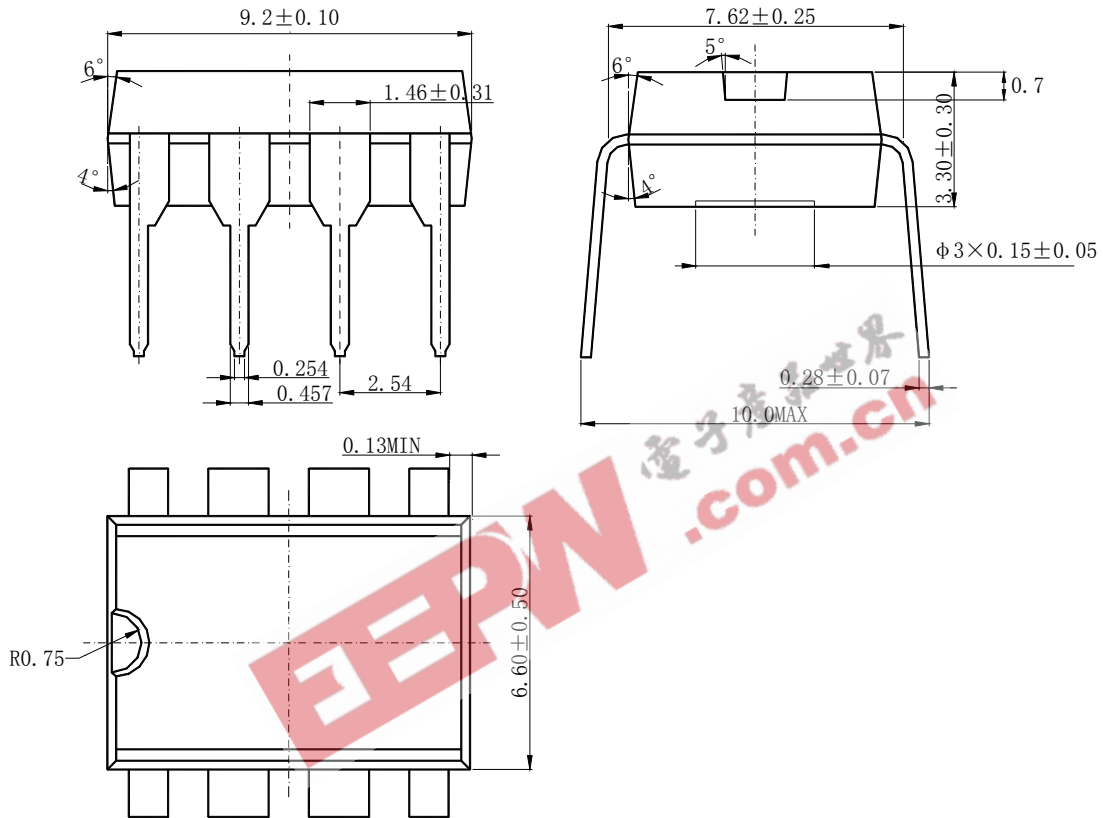



<http://www.aacmicro.com>

EPN 电子產品世界 .com.cn

USA: 1510 Montague Expressway, San Jose, CA 95131, USA

Tel: 408-433-9888, Fax: 408-432-9888

China: 8th Floor, Zone B, 900 Yi Shan Road, Shanghai 200233, China

Tel: 86-21-6495-9539, Fax: 86-21-6485-9673

Taiwan: 8F, No.50, Lane10, Kee Hu Road, Nei Hu, TaiPei 114, Taiwan

Tel: 886-2-2657-8811, Fax: 886-2-2657-9090

IMPORTANT NOTICE

Advanced Analog Circuits Corporation reserves the right to make changes to its products or specifications at any time, without notice, to improve design or performance and to supply the best possible product. Advanced Analog Circuits does not assume any responsibility for use of any circuitry described other than the circuitry embodied in Advanced Analog Circuits' products. The company makes no representation that circuitry described herein is free from patent infringement or other rights of Advanced Analog Circuits Corporation.