

**ADJUSTABLE PRECISION SHUNT REGULATORS****AZ431-B****General Description**

The AZ431-B is a three-terminal adjustable shunt regulator with guaranteed thermal stability over a full operation range. It features sharp turn-on characteristics, low temperature coefficient and low output impedance, which make it ideal substitute for Zener diode in applications such as switching power supply, charger and other adjustable regulators.

The output voltage of AZ431-B can be set to any value between  $V_{REF}$  (2.5V) and the corresponding maximum cathode voltage.

The AZ431-B precision reference is offered in two voltage tolerance: 0.4% and 0.8%.

This IC is available in 5 packages: TO-92 (bulk or ammo packing), SOT-23, SOT-23-5, SOT-89-3 and SOIC-8.

**Features**

- Programmable Precise Output Voltage from 2.5V to 18V
- High Stability under Capacitive Load
- Low Temperature Deviation: 4.5mV Typical
- Low Equivalent Full-range Temperature Coefficient with 20PPM/°C Typical
- Sink Current Capacity from 1mA to 100mA
- Low Output Noise
- Wide Operating Range of -40 to 125°C

**Applications**

- Charger
- Voltage Adapter
- Switching Power Supply
- Graphic Card
- Precision Voltage Reference

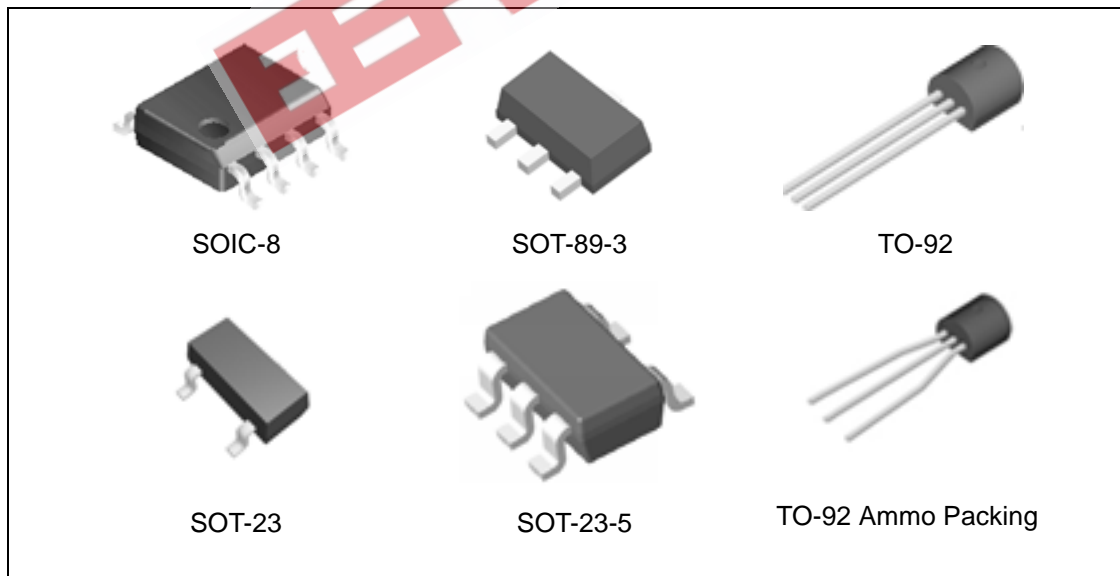

Figure 1. Package Types of AZ431-B



**ADJUSTABLE PRECISION SHUNT REGULATORS**

**AZ431-B**

**Pin Configuration**

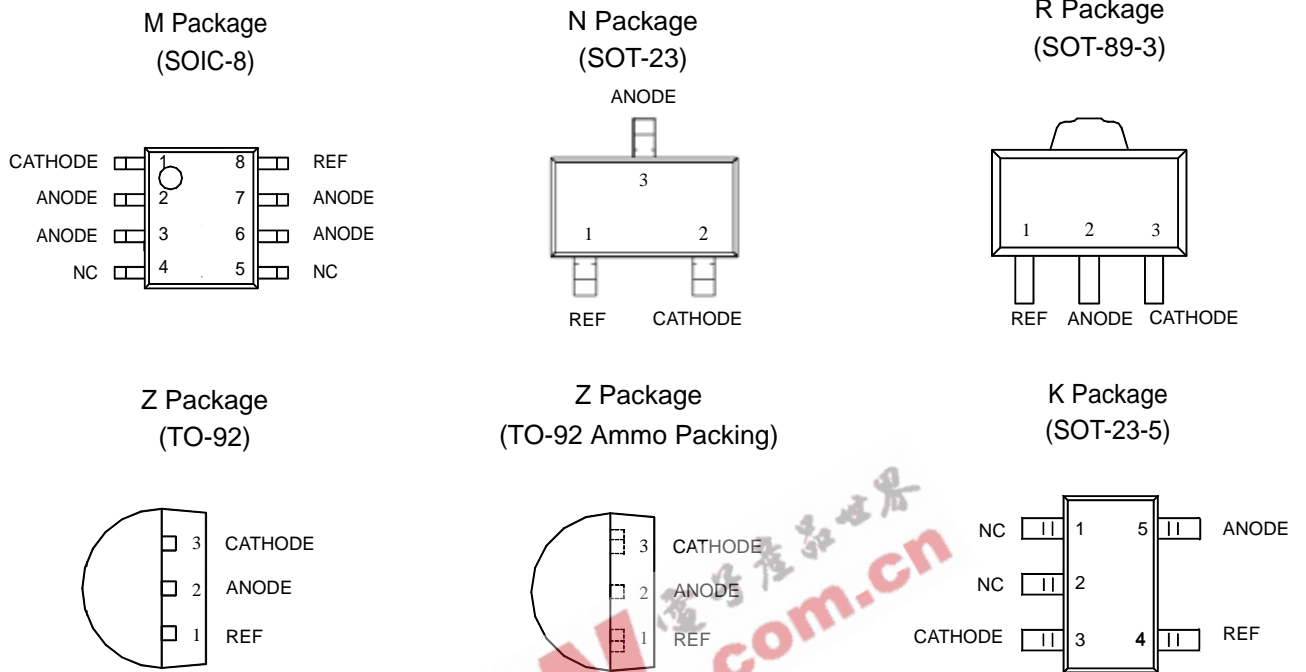

Figure 2. Pin Configuration of AZ431-B (Top View)

**Functional Block Diagram**

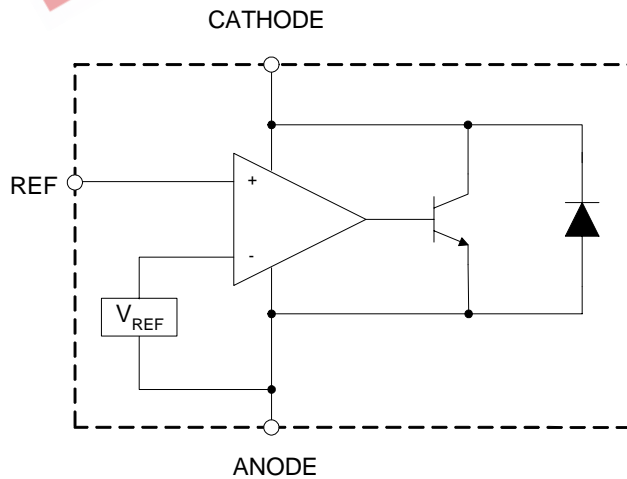

Figure 3. Functional Block Diagram of AZ431-B



**ADJUSTABLE PRECISION SHUNT REGULATORS**

**AZ431-B**

**Ordering Information**

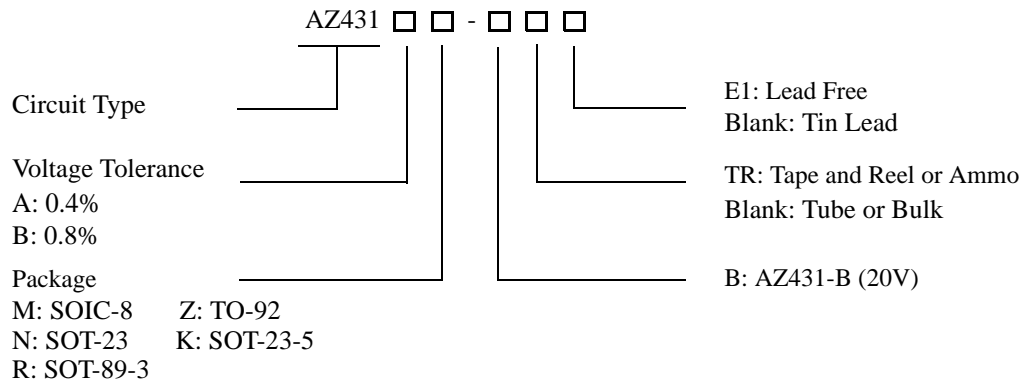

Package	Temperature Range	Voltage Tolerance	Part Number		Marking ID		Packing Type
			Tin Lead	Lead Free	Tin Lead	Lead Free	
SOT-23	-40 to 125°C	0.4%		AZ431AN-BTRE1		EA4	Tape & Reel
		0.8%		AZ431BN-BTRE1		EA5	Tape & Reel
SOT-23-5	-40 to 125°C	0.4%	AZ431AK-BTR	AZ431AK-BTRE1	K4A	E4A	Tape & Reel
		0.8%	AZ431BK-BTR	AZ431BK-BTRE1	K4B	E4B	Tape & Reel
TO-92	-40 to 125°C	0.4%	AZ431AZ-B	AZ431AZ-BE1	AZ431AZ-B	AZ431AZ-BE1	Bulk
		0.4%	AZ431AZ-BTR	AZ431AZ-BTRE1	AZ431AZ-B	AZ431AZ-BE1	Ammo
		0.8%	AZ431BZ-B	AZ431BZ-BE1	AZ431BZ-B	AZ431BZ-BE1	Bulk
		0.8%	AZ431BZ-BTR	AZ431BZ-BTRE1	AZ431BZ-B	AZ431BZ-BE1	Ammo
SOIC-8	-40 to 125°C	0.4%	AZ431AM-B	AZ431AM-BE1	AZ431AM-B	AZ431AM-BE1	Tube
		0.4%	AZ431AM-BTR	AZ431AM-BTRE1	AZ431AM-B	AZ431AM-BE1	Tape & Reel
		0.8%	AZ431BM-B	AZ431BM-BE1	AZ431BM-B	AZ431BM-BE1	Tube
		0.8%	AZ431BM-BTR	AZ431BM-BTRE1	AZ431BM-B	AZ431BM-BE1	Tape & Reel
SOT-89-3	-40 to 125°C	0.4%	AZ431AR-BTR	AZ431AR-BTRE1	431C	E43C	Tape & Reel
		0.8%	AZ431BR-BTR	AZ431BR-BTRE1	431D	E43D	Tape & Reel

BCD Semiconductor's Pb-free products, as designated with "E1" suffix in the part number, are RoHS compliant.

**ADJUSTABLE PRECISION SHUNT REGULATORS****AZ431-B****Absolute Maximum Ratings (Note 1)**

Parameter	Symbol	Value	Unit
Cathode Voltage	$V_{KA}$	20	V
Cathode Current Range (Continuous)	$I_{KA}$	-100 to 150	mA
Reference Input Current Range	$I_{REF}$	10	mA
Power Dissipation	$P_D$	M, Z, R Package: 770	mW
		N, K Package: 370	
Junction Temperature	$T_J$	150	°C
Storage Temperature Range	$T_{STG}$	-65 to 150	°C
ESD (Human Body Model)	ESD	2000	V

Note 1: Stresses greater than those listed under "Absolute Maximum Ratings" may cause permanent damage to the device. These are stress ratings only, and functional operation of the device at these or any other conditions beyond those indicated under "Recommended Operating Conditions" is not implied. Exposure to "Absolute Maximum Ratings" for extended periods may affect device reliability.

**Recommended Operating Conditions**

Parameter	Symbol	Min	Max	Unit
Cathode Voltage	$V_{KA}$	$V_{REF}$	18	V
Cathode Current	$I_{KA}$	1.0	100	mA
Operating Ambient Temperature Range	$T_A$	-40	125	°C



**ADJUSTABLE PRECISION SHUNT REGULATORS**

**AZ431-B**

**Electrical Characteristics**

Operating Conditions:  $T_A=25^{\circ}\text{C}$ , unless otherwise specified.

Parameter	Test Circuit	Symbol	Conditions	Min	Typ	Max	Unit	
Reference Voltage	0.4%	4	$V_{\text{REF}}$	$V_{\text{KA}}=V_{\text{REF}}, I_{\text{KA}}=10\text{mA}$	2.490	2.500	2.510	V
	0.8%				2.480	2.500	2.520	
Deviation of Reference Voltage Over Full Temperature Range	4	$\Delta V_{\text{REF}}$	$V_{\text{KA}}=V_{\text{REF}}$ $I_{\text{KA}}=10\text{mA}$	0 to $70^{\circ}\text{C}$	4.5	8	mV	
				-40 to $85^{\circ}\text{C}$	4.5	10		
				-40 to $125^{\circ}\text{C}$	4.5	16		
Ratio of Change in Reference Voltage to the Change in Cathode Voltage	5	$\frac{\Delta V_{\text{REF}}}{\Delta V_{\text{KA}}}$	$I_{\text{KA}}=10\text{mA}$	$\Delta V_{\text{KA}}=10\text{V to } V_{\text{REF}}$	-1.0	-2.7	mV/V	
				$\Delta V_{\text{KA}}=18\text{V to } 10\text{V}$	-0.5	-2.0		
Reference Current	5	$I_{\text{REF}}$	$I_{\text{KA}}=10\text{mA}, R1=10\text{K}\Omega, R2=\infty$		0.7	4	$\mu\text{A}$	
Deviation of Reference Current Over Full Temperature Range	5	$\Delta I_{\text{REF}}$	$I_{\text{KA}}=10\text{mA}, R1=10\text{K}\Omega, R2=\infty$ $T_A=-40$ to $125^{\circ}\text{C}$		0.4	1.2	$\mu\text{A}$	
Minimum Cathode Current for Regulation	4	$I_{\text{KA}}(\text{Min})$	$V_{\text{KA}}=V_{\text{REF}}$		0.4	1.0	mA	
Off-state Cathode Current	6	$I_{\text{KA}}(\text{Off})$	$V_{\text{KA}}=18\text{V}, V_{\text{REF}}=0$		0.05	1.0	$\mu\text{A}$	
Dynamic Impedance	4	$Z_{\text{KA}}$	$V_{\text{KA}}=V_{\text{REF}}, I_{\text{KA}}=1$ to $100\text{mA}$ $f \leq 1.0\text{KHz}$		0.2	0.5	$\Omega$	



**ADJUSTABLE PRECISION SHUNT REGULATORS**

**AZ431-B**

**Electrical Characteristics (Continued)**

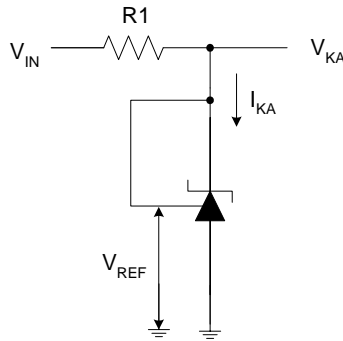

Figure 4. Test Circuit 4 for  $V_{KA} = V_{REF}$

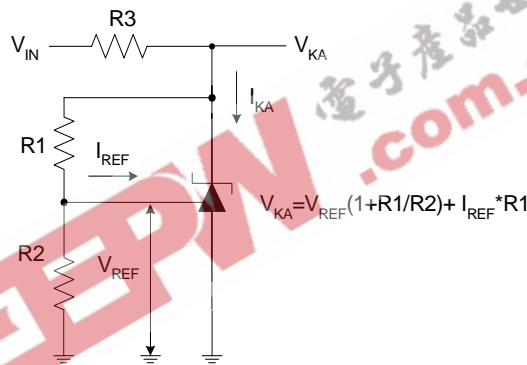

Figure 5. Test Circuit 5 for  $V_{KA} > V_{REF}$

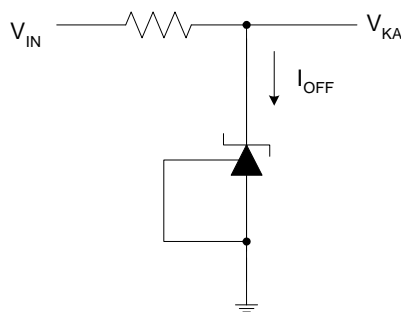

Figure 6. Test Circuit 6 for  $I_{OFF}$



**ADJUSTABLE PRECISION SHUNT REGULATORS**

**AZ431-B**

**Typical Performance Characteristics**

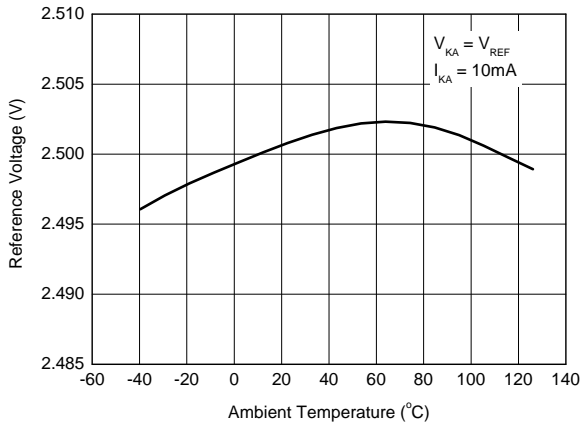

Figure 7. Reference Voltage vs. Ambient Temperature

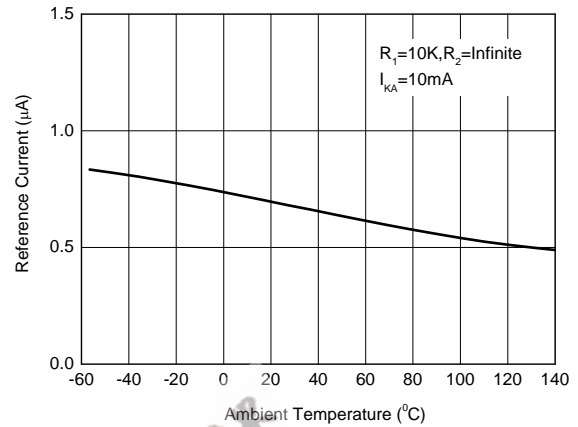

Figure 8. Reference Current vs. Ambient Temperature

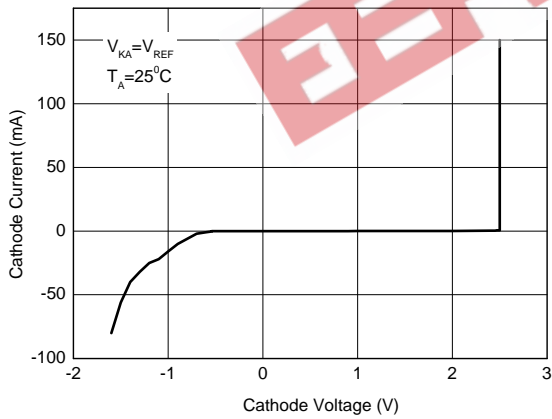

Figure 9. Cathode Current vs. Cathode Voltage

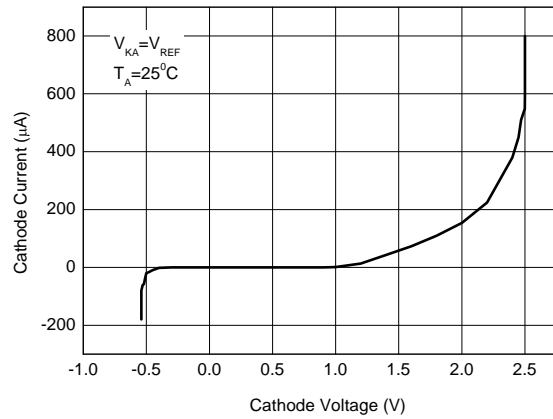

Figure 10. Cathode Current vs. Cathode Voltage



**ADJUSTABLE PRECISION SHUNT REGULATORS**

**AZ431-B**

**Typical Performance Characteristics (Continued)**

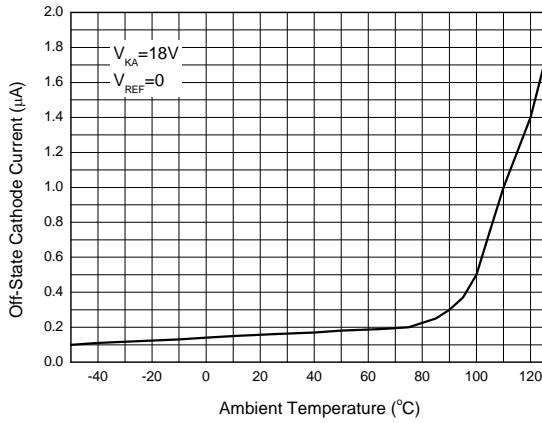

Figure 11. Off-State Cathode Current vs. Ambient Temperature

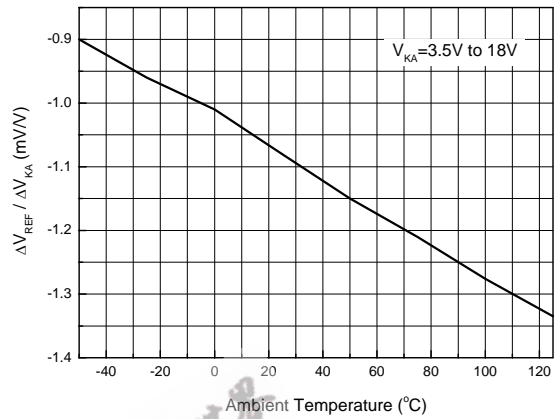

Figure 12. Ratio of Delta Reference Voltage to the Ratio of Delta Cathode Voltage

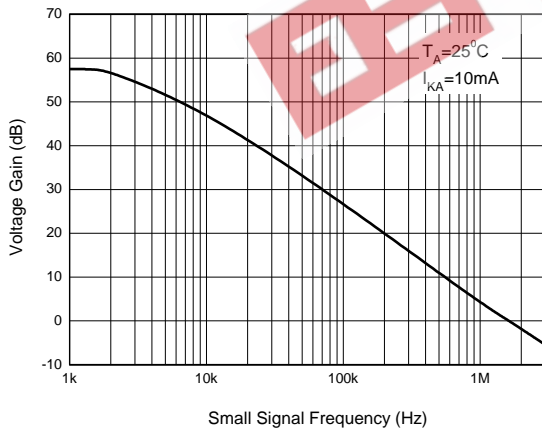
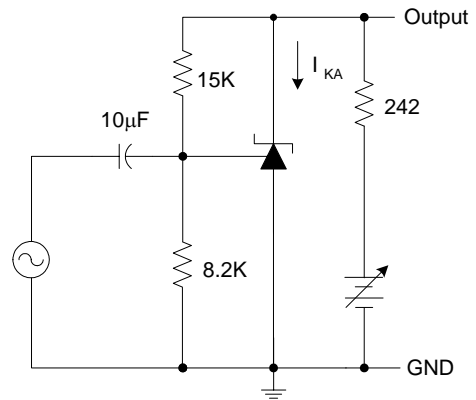

Figure 13. Small Signal Voltage Gain vs. Frequency







**ADJUSTABLE PRECISION SHUNT REGULATORS**

**AZ431-B**

**Typical Performance Characteristics (Continued)**

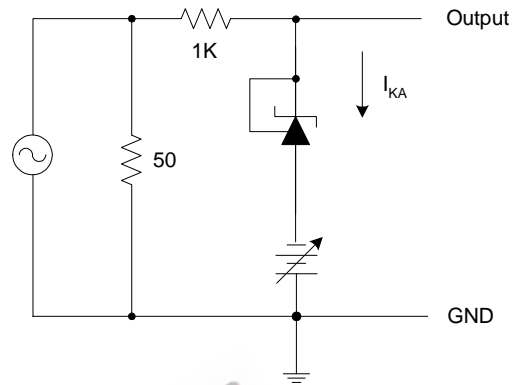
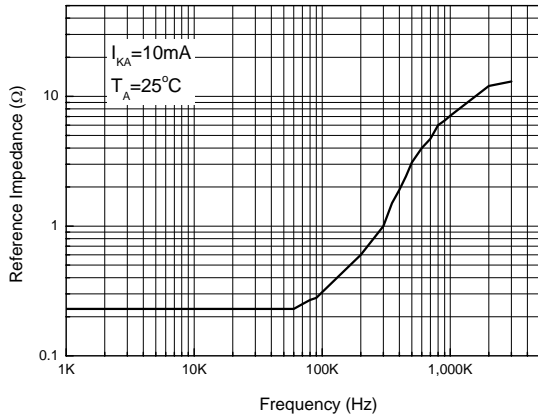

Figure 15. Reference Impedance vs. Frequency

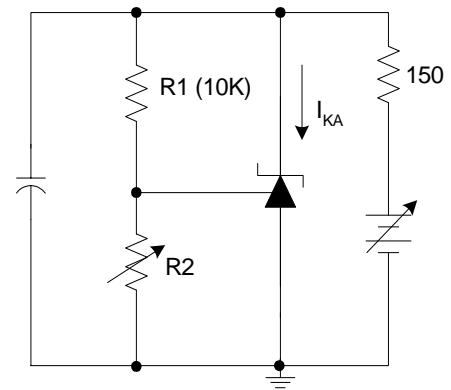
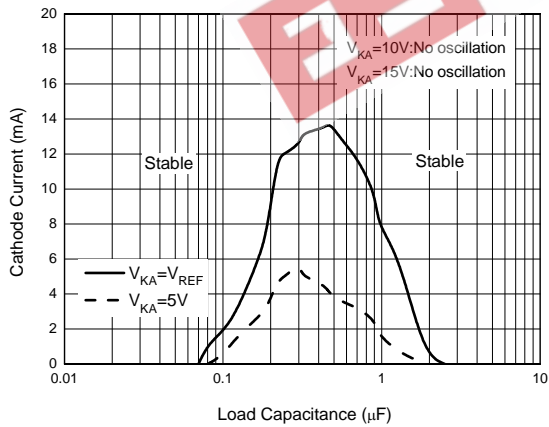

Figure 16. Stability Boundary Conditions vs. Load Capacitance



**ADJUSTABLE PRECISION SHUNT REGULATORS**

**AZ431-B**

**Typical Performance Characteristics (Continued)**

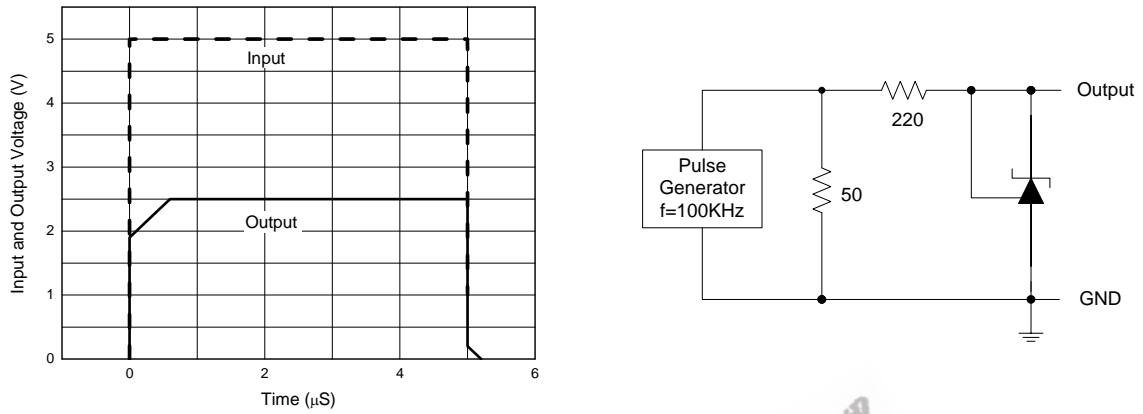

Figure 18. Pulse Response of Input and Output Voltage



**ADJUSTABLE PRECISION SHUNT REGULATORS**

**AZ431-B**

**Typical Application**

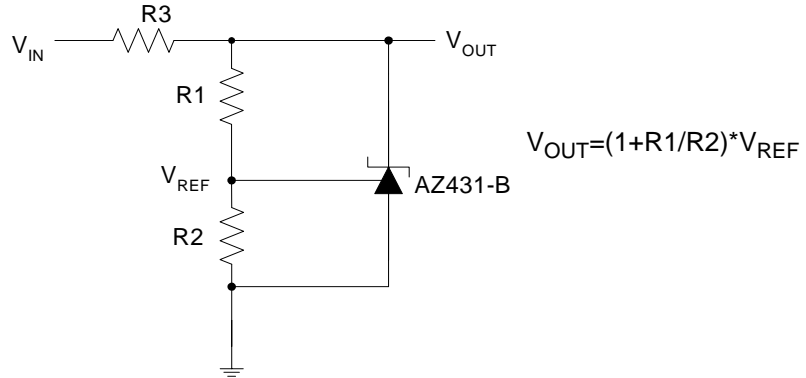

Figure 19. Shunt Regulator

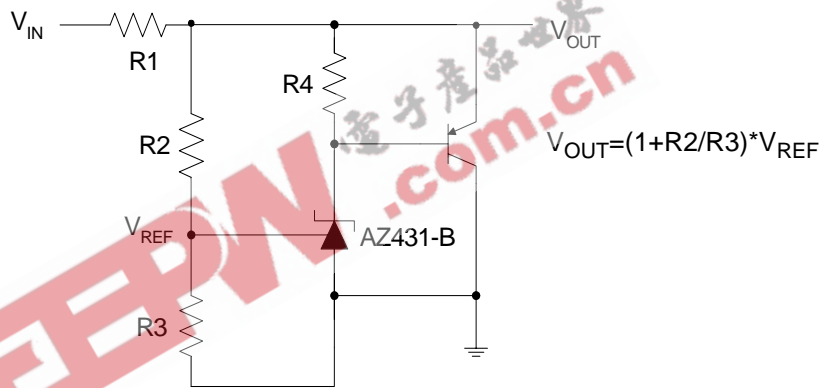

Figure 20. High Current Shunt Regulator

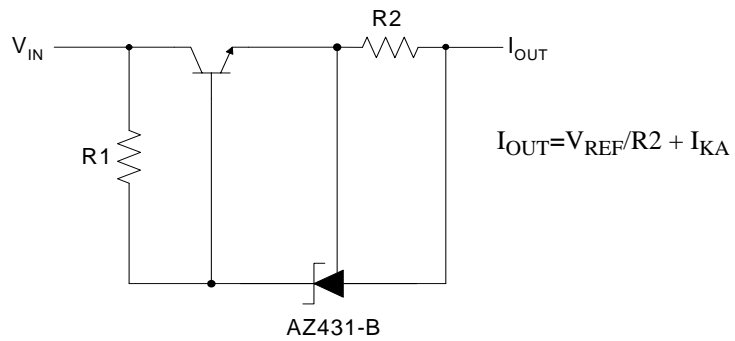

Figure 21. Current Source or Current Limit



**ADJUSTABLE PRECISION SHUNT REGULATORS**

**AZ431-B**

**Typical Application (Continued)**

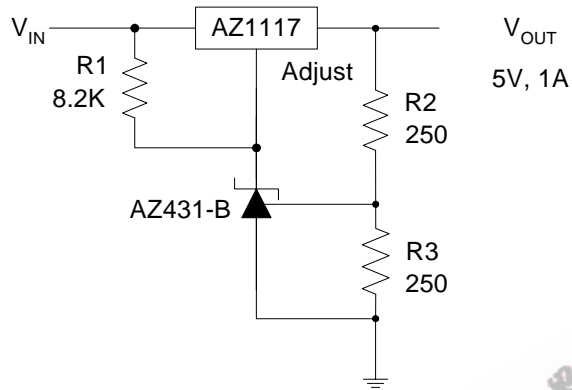

Figure 22. Precision 5V 1A Regulator

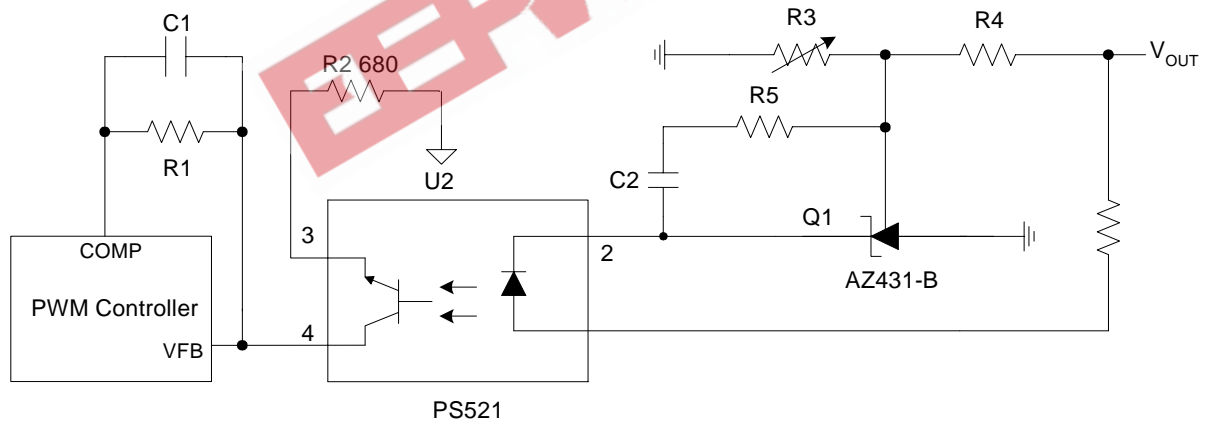

Figure 23. PWM Converter with Reference



**ADJUSTABLE PRECISION SHUNT REGULATORS**

**AZ431-B**

**Mechanical Dimensions**

**TO-92**

**Unit: mm(inch)**

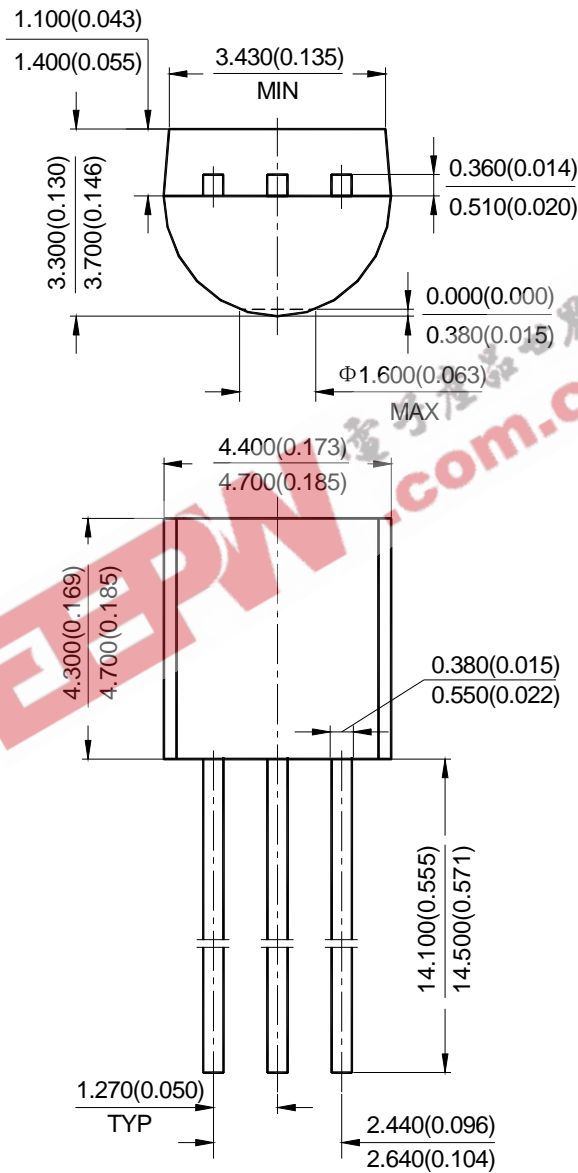



**ADJUSTABLE PRECISION SHUNT REGULATORS**

**AZ431-B**

**Mechanical Dimensions (Continued)**

**TO-92 Ammo Packing**

**Unit: mm(inch)**

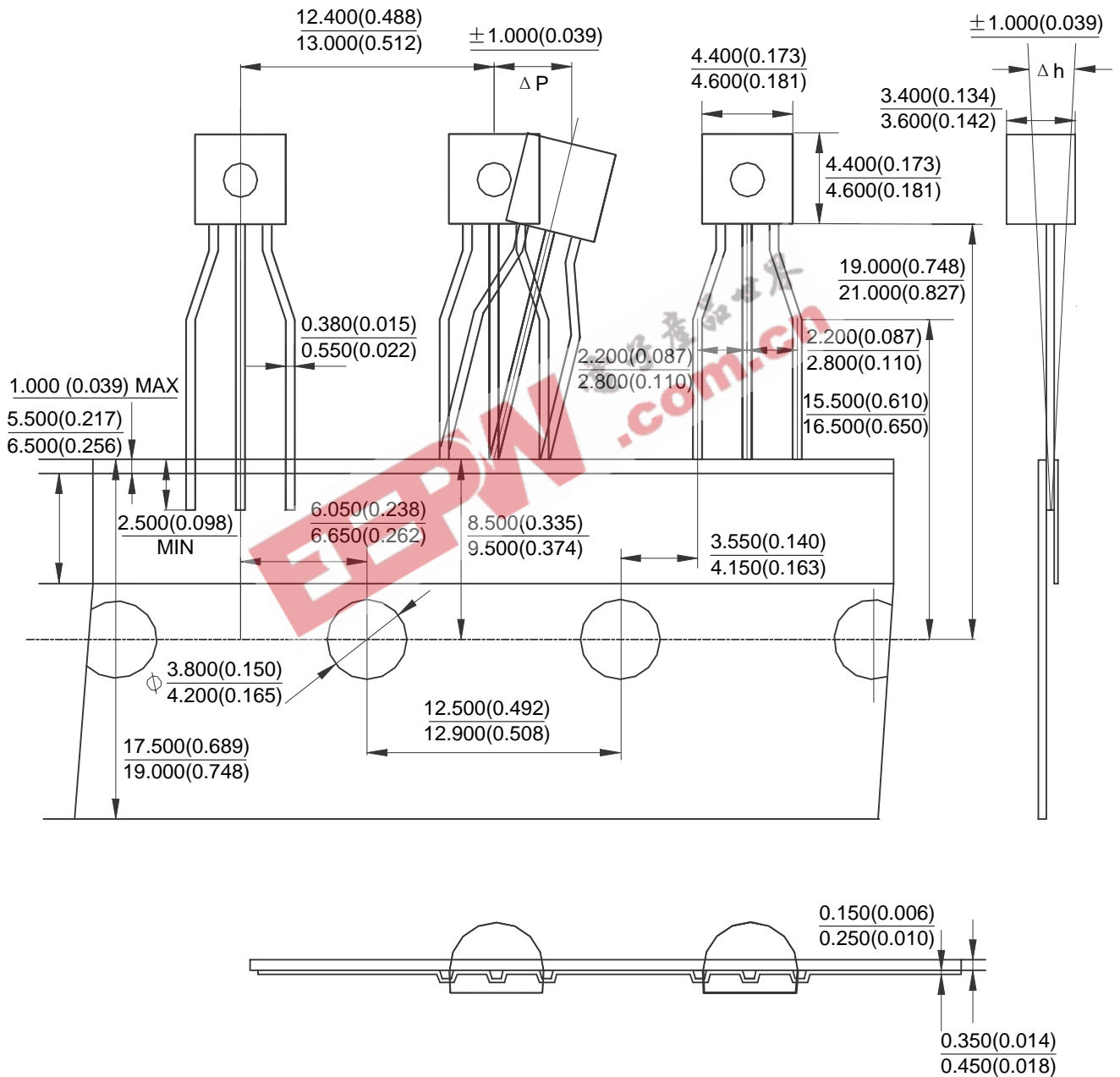



**ADJUSTABLE PRECISION SHUNT REGULATORS**

**AZ431-B**

**Mechanical Dimensions (Continued)**

**SOT-23**

**Unit: mm(inch)**

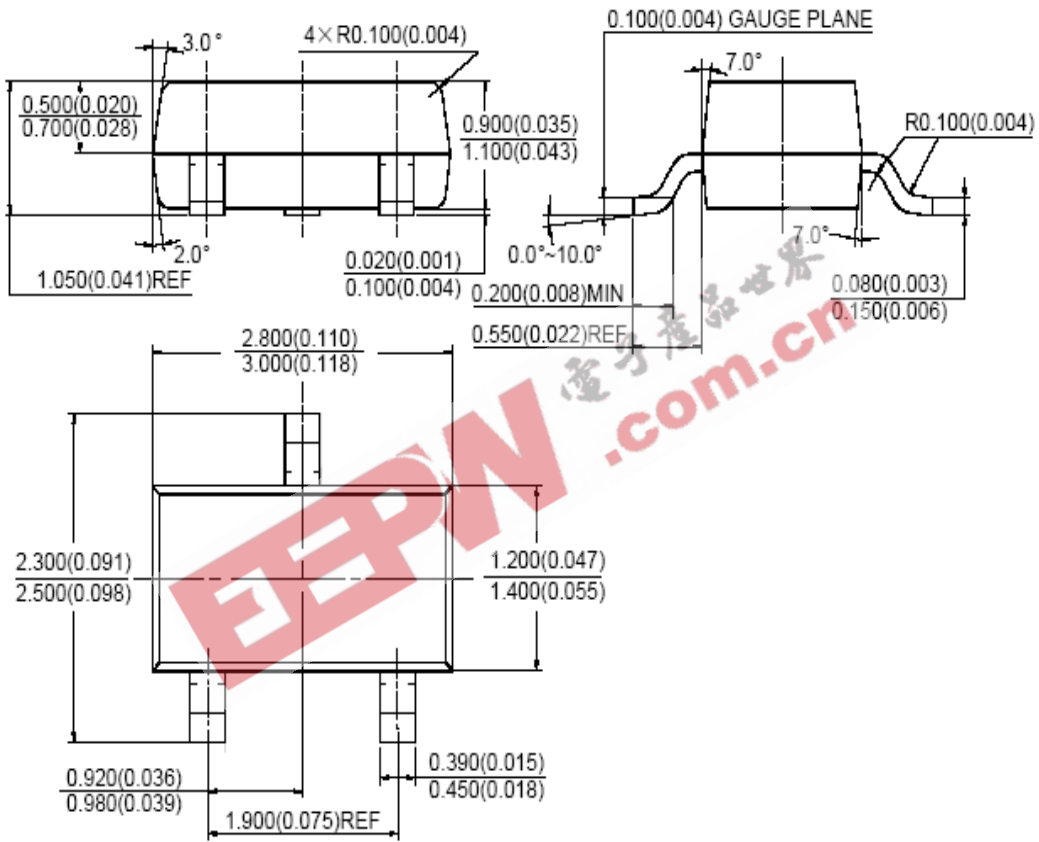



**ADJUSTABLE PRECISION SHUNT REGULATORS**

**AZ431-B**

**Mechanical Dimensions (Continued)**

**SOT-23-5**

**Unit: mm(inch)**

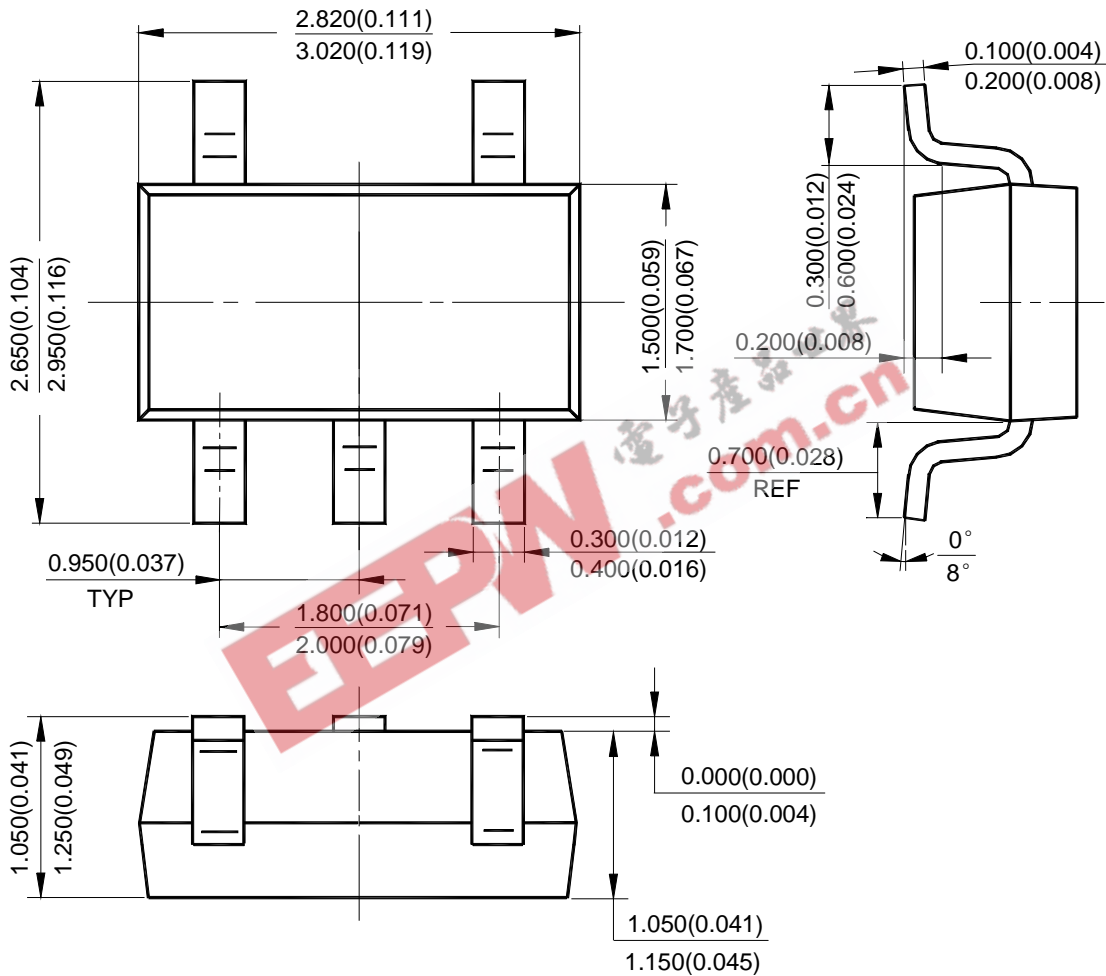





**ADJUSTABLE PRECISION SHUNT REGULATORS**

**AZ431-B**

**Mechanical Dimensions (Continued)**

**SOT-89-3**

**Unit: mm(inch)**

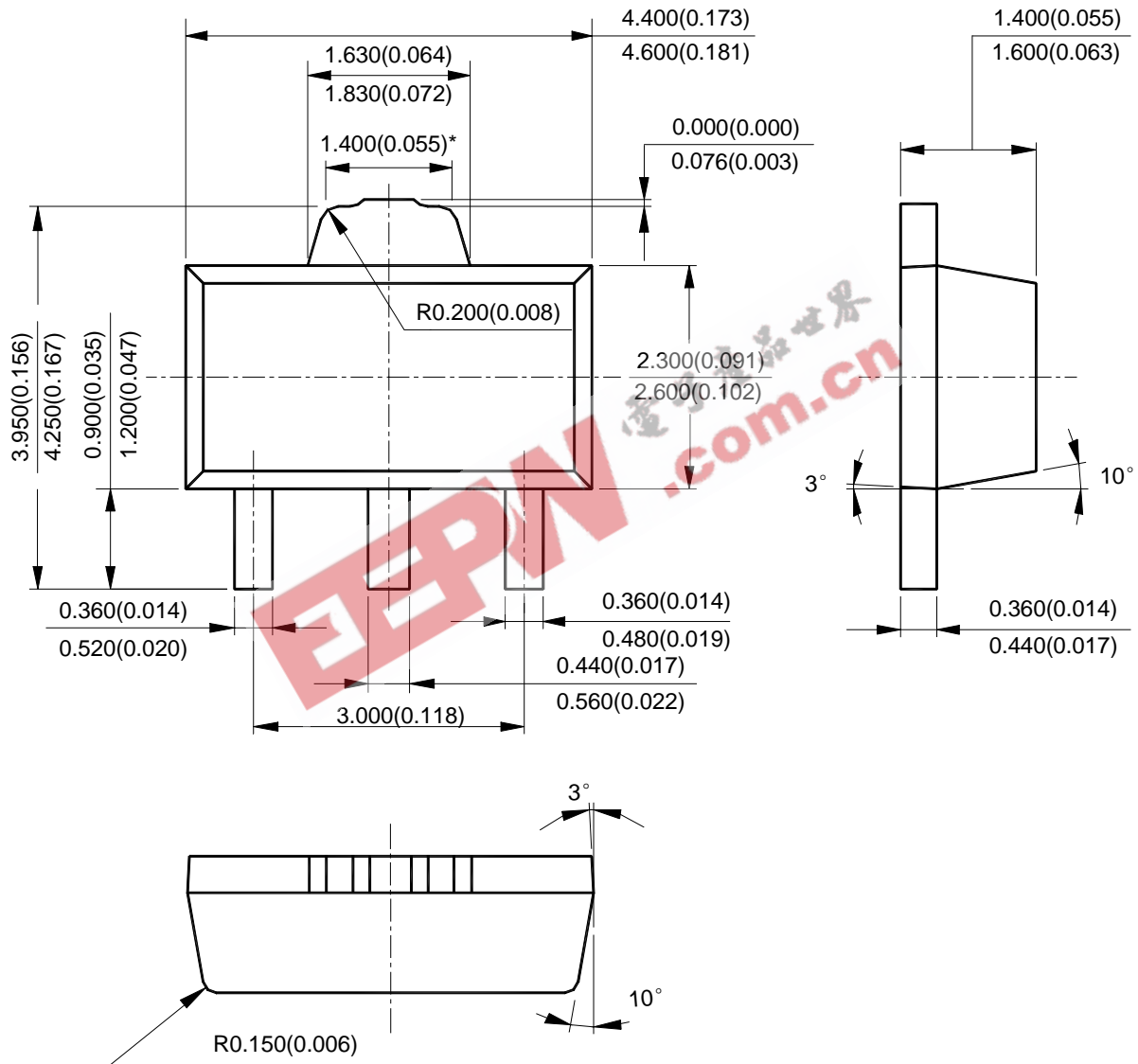



**ADJUSTABLE PRECISION SHUNT REGULATORS**

**AZ431-B**

**Mechanical Dimensions (Continued)**

**SOIC-8**

**Unit: mm(inch)**

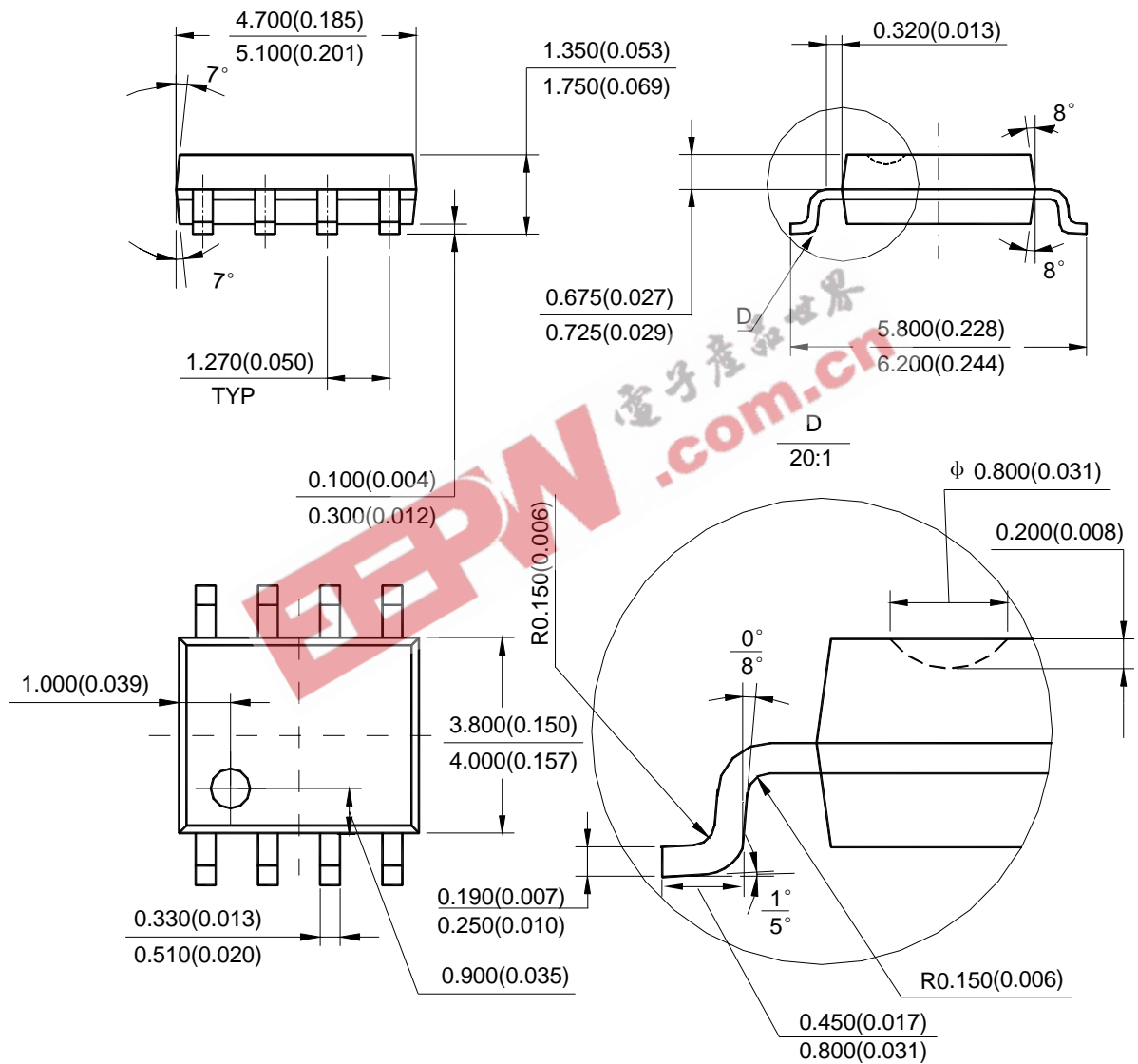



BCD Semiconductor Manufacturing Limited

<http://www.bcdsemi.com>

EEPW.com.cn  
电子产品世界

#### IMPORTANT NOTICE

BCD Semiconductor Manufacturing Limited reserves the right to make changes without further notice to any products or specifications herein. BCD Semiconductor Manufacturing Limited does not assume any responsibility for use of any its products for any particular purpose, nor does BCD Semiconductor Manufacturing Limited assume any liability arising out of the application or use of any its products or circuits. BCD Semiconductor Manufacturing Limited does not convey any license under its patent rights or other rights nor the rights of others.

---

#### MAIN SITE

**BCD Semiconductor Manufacturing Limited**  
- Wafer Fab  
Shanghai SIM-BCD Semiconductor Manufacturing Limited  
800, Yi Shan Road, Shanghai 200233, China  
Tel: +86-21-6485 1491, Fax: +86-21-5450 0008

**BCD Semiconductor Manufacturing Limited**  
- IC Design Group  
Advanced Analog Circuits (Shanghai) Corporation  
8F, Zone B, 900, Yi Shan Road, Shanghai 200233, China  
Tel: +86-21-6495 9539, Fax: +86-21-6485 9673

#### REGIONAL SALES OFFICE

**Shenzhen Office**  
Shanghai SIM-BCD Semiconductor Manufacturing Co., Ltd. Shenzhen Office  
Advanced Analog Circuits (Shanghai) Corporation Shenzhen Office  
Room E, 5F, Noble Center, No.1006, 3rd Fuzhong Road, Futian District, Shenzhen 518026, China  
Tel: +86-755-8826 7951  
Fax: +86-755-8826 7865

**Taiwan Office**  
BCD Semiconductor (Taiwan) Company Limited  
4F, 298-1, Rui Guang Road, Nei-Hu District, Taipei,  
Taiwan  
Tel: +886-2-2656 2808  
Fax: +886-2-2656 2806

**USA Office**  
BCD Semiconductor Corporation  
30920 Huntwood Ave. Hayward,  
CA 94544, U.S.A  
Tel: +1-510-324-2988  
Fax: +1-510-324-2788