

- Designed for Complementary Use with BDW24, BDW24A, BDW24B and BDW24C
- 50 W at 25°C Case Temperature
- 6 A Continuous Collector Current
- Minimum h_{FE} of 750 at 3V, 2 A

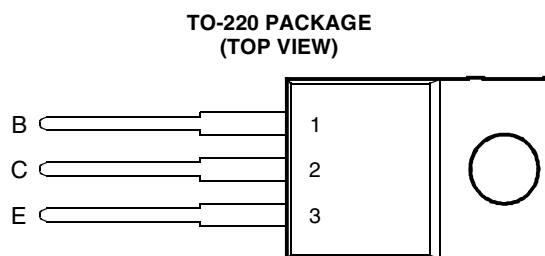

Pin 2 is in electrical contact with the mounting base.

MDTRACA

absolute maximum ratings at 25°C case temperature (unless otherwise noted)

RATING		SYMBOL	VALUE	UNIT
Collector-base voltage ($I_E = 0$)	BDW23	V_{CBO}	45	V
	BDW23A		60	
	BDW23B		80	
	BDW23C		100	
Collector-emitter voltage ($I_B = 0$)	BDW23	V_{CEO}	45	V
	BDW23A		60	
	BDW23B		80	
	BDW23C		100	
Emitter-base voltage		V_{EBO}	5	V
Continuous collector current		I_C	6	A
Continuous base current		I_B	0.2	A
Continuous device dissipation at (or below) 25°C case temperature (see Note 1)		P_{tot}	50	W
Continuous device dissipation at (or below) 25°C free air temperature (see Note 2)		P_{tot}	2	W
Operating junction temperature range		T_j	-65 to +150	°C
Storage temperature range		T_{stg}	-65 to +150	°C
Operating free-air temperature range		T_A	-65 to +150	°C

NOTES: 1. Derate linearly to 150°C case temperature at the rate of 0.4 W/°C.
2. Derate linearly to 150°C free air temperature at the rate of 16 mW/°C.

PRODUCT INFORMATION

electrical characteristics at 25°C case temperature (unless otherwise noted)

PARAMETER	TEST CONDITIONS			MIN	TYP	MAX	UNIT
$V_{(BR)CEO}$ Collector-emitter breakdown voltage	$I_C = 100 \text{ mA}$	$I_B = 0$	(see Note 3)	BDW23 BDW23A BDW23B BDW23C	45 60 80 100		V
I_{CEO} Collector-emitter cut-off current	$V_{CE} = 30 \text{ V}$ $V_{CE} = 30 \text{ V}$ $V_{CE} = 40 \text{ V}$ $V_{CE} = 50 \text{ V}$	$I_B = 0$ $I_B = 0$ $I_B = 0$ $I_B = 0$		BDW23 BDW23A BDW23B BDW23C		0.5 0.5 0.5 0.5	mA
I_{CBO} Collector cut-off current	$V_{CB} = 45 \text{ V}$ $V_{CB} = 60 \text{ V}$ $V_{CB} = 80 \text{ V}$ $V_{CB} = 100 \text{ V}$	$I_E = 0$ $I_E = 0$ $I_E = 0$ $I_E = 0$		BDW23 BDW23A BDW23B BDW23C		0.2 0.2 0.2 0.2	mA
I_{EBO} Emitter cut-off current	$V_{EB} = 5 \text{ V}$	$I_C = 0$				2	mA
h_{FE} Forward current transfer ratio	$V_{CE} = 3 \text{ V}$ $V_{CE} = 3 \text{ V}$ $V_{CE} = 3 \text{ V}$	$I_C = 1 \text{ A}$ $I_C = 2 \text{ A}$ $I_C = 6 \text{ A}$	(see Notes 3 and 4)		1000 750 100	20000	
$V_{CE(sat)}$ Collector-emitter saturation voltage	$I_B = 8 \text{ mA}$ $I_B = 60 \text{ mA}$	$I_C = 2 \text{ A}$ $I_C = 6 \text{ A}$	(see Notes 3 and 4)			2 3	V
$V_{BE(sat)}$ Base-emitter saturation voltage	$I_B = 8 \text{ mA}$	$I_C = 2 \text{ A}$	(see Notes 3 and 4)			2.5	
$V_{BE(on)}$ Base-emitter voltage	$V_{CE} = 3 \text{ V}$ $V_{CE} = 3 \text{ V}$	$I_C = 1 \text{ A}$ $I_C = 6 \text{ A}$	(see Notes 3 and 4)			2.5 3	V
V_{EC} Parallel diode forward voltage	$I_E = 2 \text{ A}$	$I_B = 0$				1.8	V

NOTES: 3. These parameters must be measured using pulse techniques, $t_p = 300 \mu\text{s}$, duty cycle $\leq 2\%$.

4. These parameters must be measured using voltage-sensing contacts, separate from the current carrying contacts.

thermal characteristics

PARAMETER	MIN	TYP	MAX	UNIT
$R_{\theta JC}$ Junction to case thermal resistance			2.5	°C/W
$R_{\theta JA}$ Junction to free air thermal resistance			62.5	°C/W

resistive-load-switching characteristics at 25°C case temperature

PARAMETER	TEST CONDITIONS †			MIN	TYP	MAX	UNIT
t_{on} Turn-on time	$I_C = 3 \text{ A}$	$I_{B(on)} = 12 \text{ mA}$	$I_{B(off)} = -12 \text{ mA}$		1		μs
t_{off} Turn-off time	$V_{BE(off)} = -4.5 \text{ V}$	$R_L = 10 \Omega$	$t_p = 20 \mu\text{s}$, dc $\leq 2\%$		5		μs

† Voltage and current values shown are nominal; exact values vary slightly with transistor parameters.

TYPICAL CHARACTERISTICS

**TYPICAL DC CURRENT GAIN
vs
COLLECTOR CURRENT**

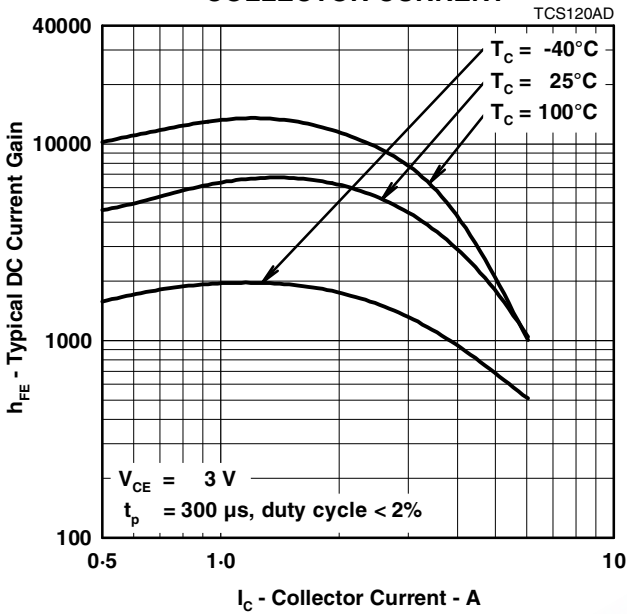

Figure 1.

**COLLECTOR-EMITTER SATURATION VOLTAGE
vs
COLLECTOR CURRENT**

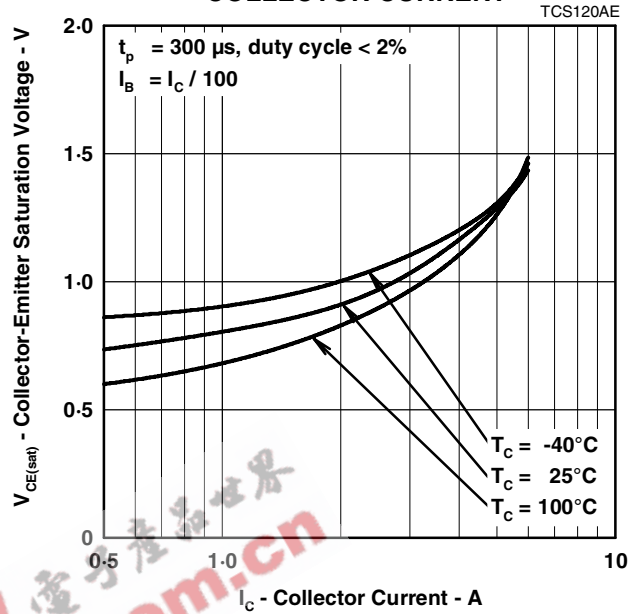

Figure 2.

**BASE-EMITTER SATURATION VOLTAGE
vs
COLLECTOR CURRENT**

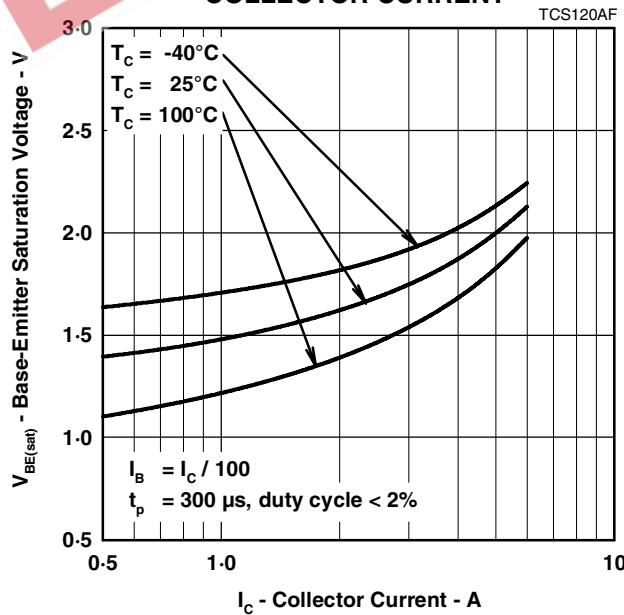

Figure 3.

PRODUCT INFORMATION

AUGUST 1993 - REVISED SEPTEMBER 2002
Specifications are subject to change without notice.

MAXIMUM SAFE OPERATING REGIONS

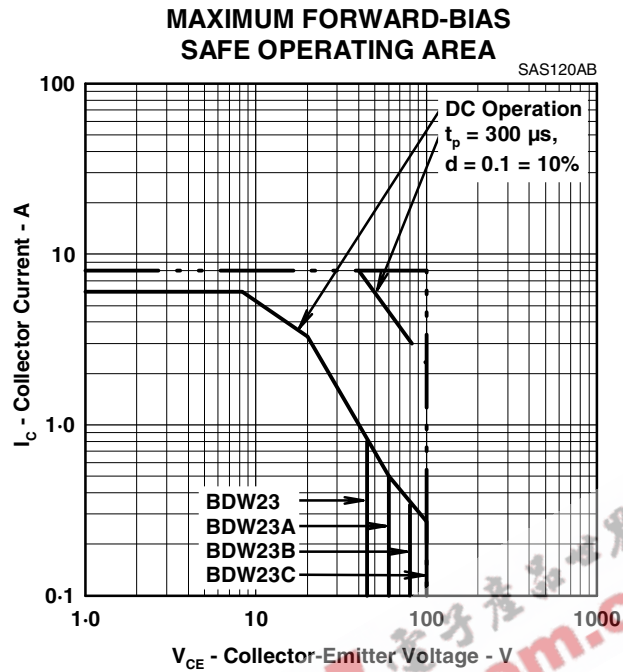

Figure 4.

THERMAL INFORMATION

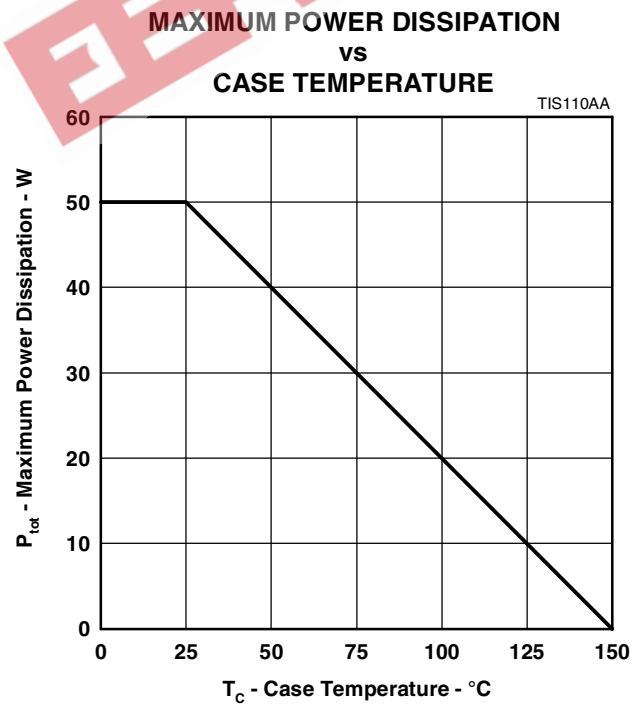

Figure 5.

PRODUCT INFORMATION

AUGUST 1993 - REVISED SEPTEMBER 2002
Specifications are subject to change without notice.

MECHANICAL DATA

TO-220
3-pin plastic flange-mount package

This single-in-line package consists of a circuit mounted on a lead frame and encapsulated within a plastic compound. The compound will withstand soldering temperature with no deformation, and circuit performance characteristics will remain stable when operated in high humidity conditions. Leads require no additional cleaning or processing when used in soldered assembly.

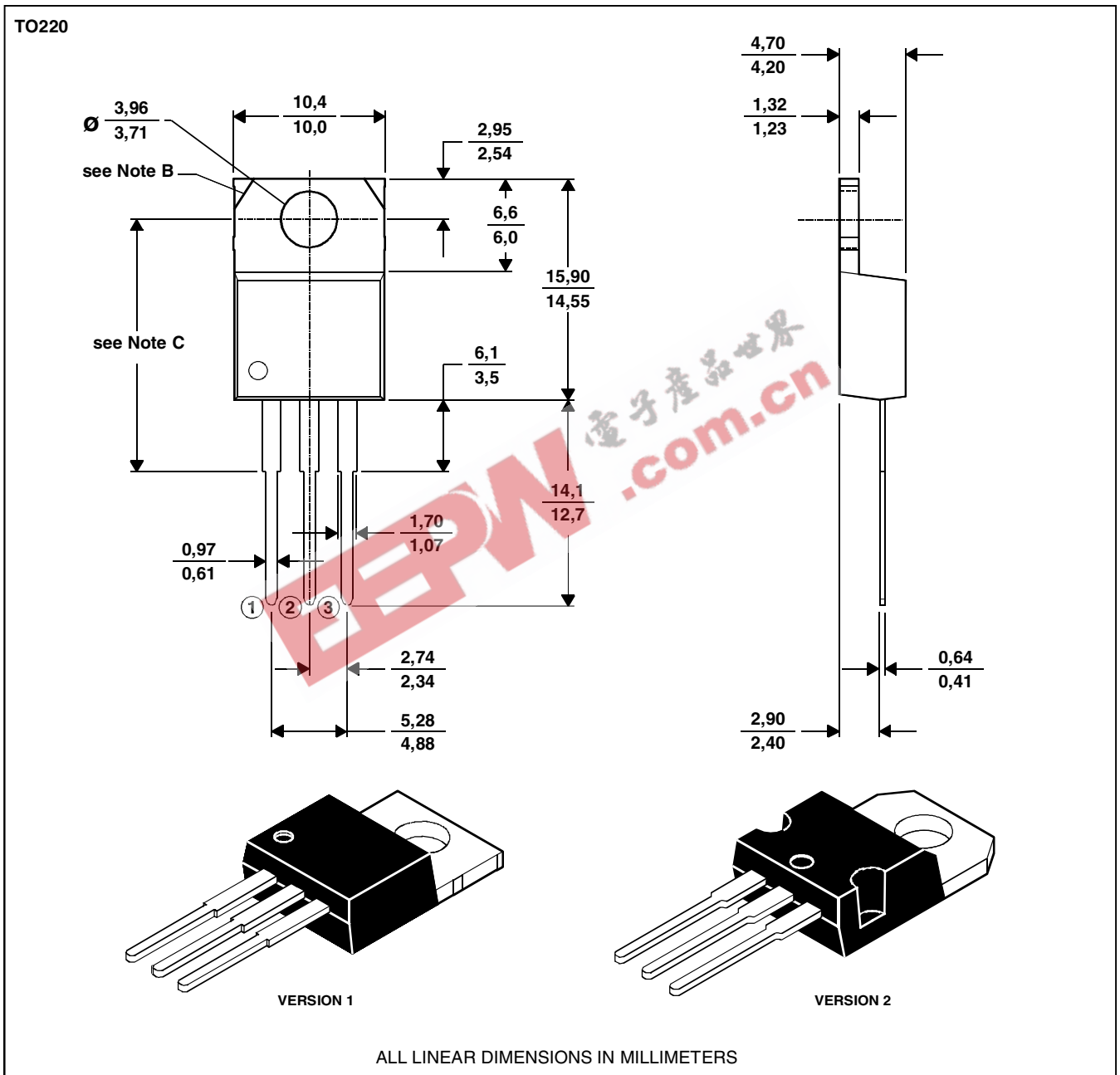

NOTES: A. The centre pin is in electrical contact with the mounting tab.
 B. Mounting tab corner profile according to package version.
 C. Typical fixing hole centre stand off height according to package version.
 Version 1, 18.0 mm. Version 2, 17.6 mm.

MDXXBE

PRODUCT INFORMATION

AUGUST 1993 - REVISED SEPTEMBER 2002
 Specifications are subject to change without notice.