

# BDW42 - NPN, BDW46, BDW47 - PNP

BDW42 and BDW47 are Preferred Devices

## Darlington Complementary Silicon Power Transistors

This series of plastic, medium-power silicon NPN and PNP Darlington transistors are designed for general purpose and low speed switching applications.

### Features

- High DC Current Gain –  $h_{FE} = 2500$  (typ) @  $I_C = 5.0$  Adc.
- Collector Emitter Sustaining Voltage @ 30 mAdc:  
 $V_{CE(sus)} = 80$  Vdc (min) – BDW46  
 $100$  Vdc (min) – BDW42/BDW47
- Low Collector Emitter Saturation Voltage  
 $V_{CE(sat)} = 2.0$  Vdc (max) @  $I_C = 5.0$  Adc  
 $3.0$  Vdc (max) @  $I_C = 10.0$  Adc
- Monolithic Construction with Built-In Base Emitter Shunt resistors
- TO-220AB Compact Package
- Pb-Free Packages Are Available\*

### MAXIMUM RATINGS

Rating	Symbol	Value	Unit
Collector-Emitter Voltage	$V_{CEO}$	80 100	Vdc
	BDW46 BDW42, BDW47		
Collector-Base Voltage	$V_{CB}$	80 100	Vdc
	BDW46 BDW42, BDW47		
Emitter-Base Voltage	$V_{EB}$	5.0	Vdc
Collector Current	$I_C$	15	Adc
Base Current	$I_B$	0.5	Adc
Total Device Dissipation @ $T_C = 25^\circ\text{C}$ Derate above $25^\circ\text{C}$	$P_D$	85 0.68	W W/ $^\circ\text{C}$
Operating and Storage Junction Temperature Range	$T_J, T_{stg}$	-55 to +150	$^\circ\text{C}$

### THERMAL CHARACTERISTICS

Characteristic	Symbol	Max	Unit
Thermal Resistance, Junction-to-Case	$R_{\theta JC}$	1.47	$^\circ\text{C}/\text{W}$

Maximum ratings are those values beyond which device damage can occur. Maximum ratings applied to the device are individual stress limit values (not normal operating conditions) and are not valid simultaneously. If these limits are exceeded, device functional operation is not implied, damage may occur and reliability may be affected.

\*For additional information on our Pb-Free strategy and soldering details, please download the ON Semiconductor Soldering and Mounting Techniques Reference Manual, SOLDERRM/D.



ON Semiconductor®

<http://onsemi.com>

## 15 AMP DARLINGTON COMPLEMENTARY SILICON POWER TRANSISTORS 80-100 VOLT, 85 WATT

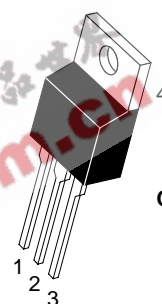

TO-220AB  
CASE 221A-09  
STYLE 1

### MARKING DIAGRAM

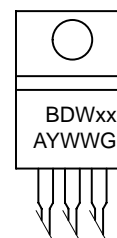

BDWxx = Device Code  
x = 42, 46, or 47  
A = Assembly Location  
Y = Year  
WW = Work Week  
G = Pb-Free Package

### ORDERING INFORMATION

Device	Package	Shipping
BDW42	TO-220AB	50 Units/Rail
BDW42G	TO-220AB (Pb-Free)	50 Units/Rail
BDW46	TO-220AB	50 Units/Rail
BDW46G	TO-220AB (Pb-Free)	50 Units/Rail
BDW47	TO-220AB	50 Units/Rail
BDW47G	TO-220AB (Pb-Free)	50 Units/Rail

Preferred devices are ON Semiconductor recommended choices for future use and best overall value

## BDW42 – NPN, BDW46, BDW47 – PNP

### ELECTRICAL CHARACTERISTICS (T<sub>C</sub> = 25°C unless otherwise noted)

Characteristic	Symbol	Min	Max	Unit	
<b>OFF CHARACTERISTICS</b>					
Collector Emitter Sustaining Voltage (Note 1) (I <sub>C</sub> = 30 mA <sub>dc</sub> , I <sub>B</sub> = 0)	BDW46 BDW42/BDW47	V <sub>CEO(sus)</sub>	80 100	– –	V <sub>dc</sub>
Collector Cutoff Current (V <sub>CE</sub> = 40 V <sub>dc</sub> , I <sub>B</sub> = 0) (V <sub>CE</sub> = 50 V <sub>dc</sub> , I <sub>B</sub> = 0)	BDW46 BDW42/BDW47	I <sub>CEO</sub>	– –	2.0 2.0	mA <sub>dc</sub>
Collector Cutoff Current (V <sub>CB</sub> = 80 V <sub>dc</sub> , I <sub>E</sub> = 0) (V <sub>CB</sub> = 100 V <sub>dc</sub> , I <sub>E</sub> = 0)	BDW46 BDW42/BDW47	I <sub>CBO</sub>	– –	1.0 1.0	mA <sub>dc</sub>
Emitter Cutoff Current (V <sub>BE</sub> = 5.0 V <sub>dc</sub> , I <sub>C</sub> = 0)		I <sub>EBO</sub>	–	2.0	mA <sub>dc</sub>

### ON CHARACTERISTICS (Note 1)

DC Current Gain (I <sub>C</sub> = 5.0 A <sub>dc</sub> , V <sub>CE</sub> = 4.0 V <sub>dc</sub> ) (I <sub>C</sub> = 10 A <sub>dc</sub> , V <sub>CE</sub> = 4.0 V <sub>dc</sub> )		h <sub>FE</sub>	1000 250	– –	
Collector–Emitter Saturation Voltage (I <sub>C</sub> = 5.0 A <sub>dc</sub> , I <sub>B</sub> = 10 mA <sub>dc</sub> ) (I <sub>C</sub> = 10 A <sub>dc</sub> , I <sub>B</sub> = 50 mA <sub>dc</sub> )		V <sub>CE(sat)</sub>	– –	2.0 3.0	V <sub>dc</sub>
Base–Emitter On Voltage (I <sub>C</sub> = 10 A <sub>dc</sub> , V <sub>CE</sub> = 4.0 V <sub>dc</sub> )		V <sub>BE(on)</sub>	–	3.0	V <sub>dc</sub>

### SECOND BREAKDOWN (Note 2)

Second Breakdown Collector Current with Base Forward Biased BDW42 BDW46/BDW47	V <sub>CE</sub> = 28.4 V <sub>dc</sub> V <sub>CE</sub> = 40 V <sub>dc</sub> V <sub>CE</sub> = 22.5 V <sub>dc</sub> V <sub>CE</sub> = 36 V <sub>dc</sub>	I <sub>S/b</sub>	3.0 1.2 3.8 1.2	– – – –	A <sub>dc</sub>
--	--	------------------	--------------------------	------------------	-----------------

### DYNAMIC CHARACTERISTICS

Magnitude of common emitter small signal short circuit current transfer ratio (I <sub>C</sub> = 3.0 A <sub>dc</sub> , V <sub>CE</sub> = 3.0 V <sub>dc</sub> , f = 1.0 MHz)		f <sub>T</sub>	4.0	–	MHz
Output Capacitance (V <sub>CB</sub> = 10 V <sub>dc</sub> , I <sub>E</sub> = 0, f = 0.1 MHz)	BDW42 BDW46/BDW47	C <sub>ob</sub>	– –	200 300	pF
Small–Signal Current Gain (I <sub>C</sub> = 3.0 A <sub>dc</sub> , V <sub>CE</sub> = 3.0 V <sub>dc</sub> , f = 1.0 kHz)		h <sub>fe</sub>	300	–	

1. Pulse Test: Pulse Width = 300 μs, Duty Cycle = 2.0%.
2. Pulse Test non repetitive: Pulse Width = 250 ms.

## BDW42 – NPN, BDW46, BDW47 – PNP

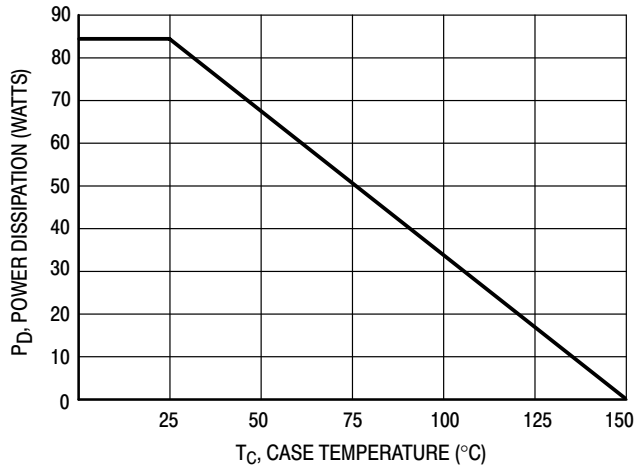

**Figure 1. Power Temperature Derating Curve**

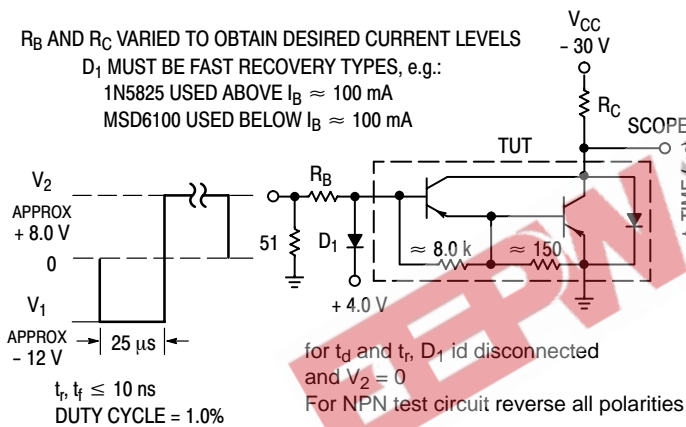

**Figure 2. Switching Times Test Circuit**

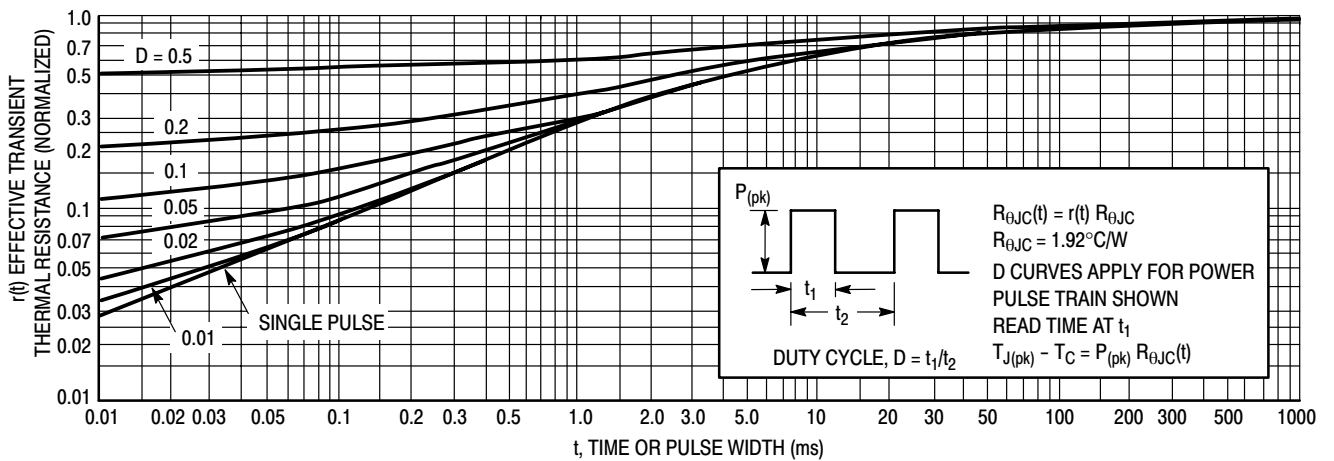
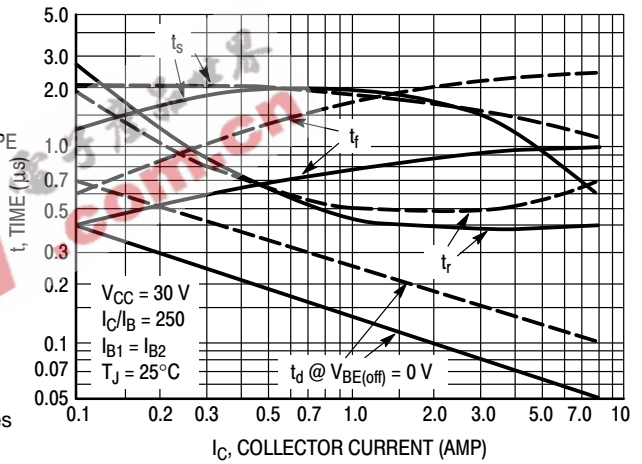

# BDW42 – NPN, BDW46, BDW47 – PNP

## ACTIVE-REGION SAFE OPERATING AREA

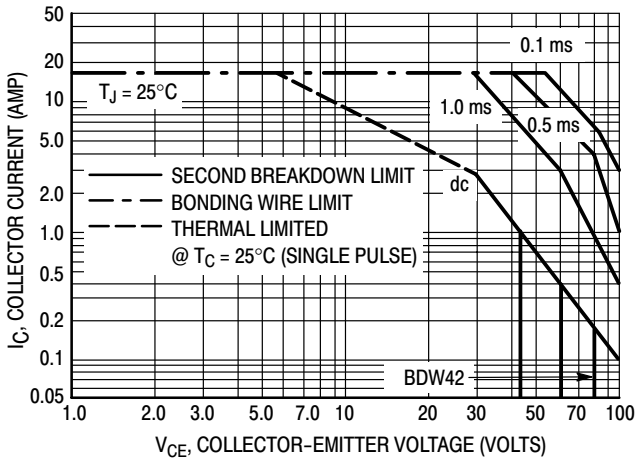

Figure 5. BDW42

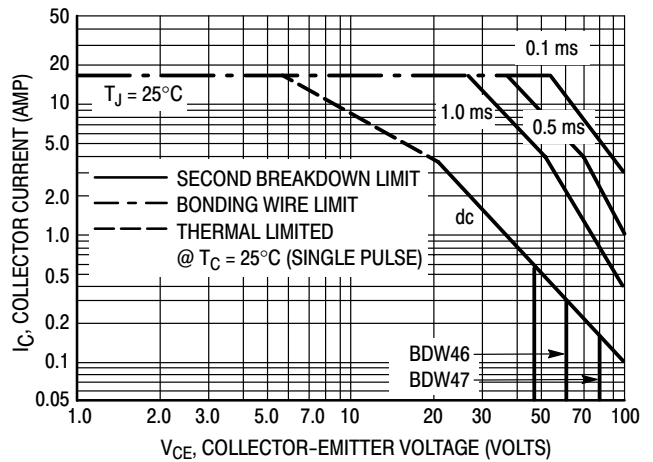

Figure 6. BDW46 and BDW47

There are two limitations on the power handling ability of a transistor: average junction temperature and second breakdown. Safe operating area curves indicate  $I_C - V_{CE}$  limits of the transistor that must be observed for reliable operation; i.e., the transistor must not be subjected to greater dissipation than the curves indicate. The data of Figure 5 and 6 is based on  $T_{J(pk)} = 200^\circ\text{C}$ ;  $T_C$  is variable depending on conditions.

Second breakdown pulse limits are valid for duty cycles to 10% provided  $T_{J(pk)} \leq 200^\circ\text{C}$ .  $T_{J(pk)}$  may be calculated from the data in Figure 4. At high case temperatures, thermal limitations will reduce the power that can be handled to values less than the limitations imposed by second breakdown.

\*Linear extrapolation

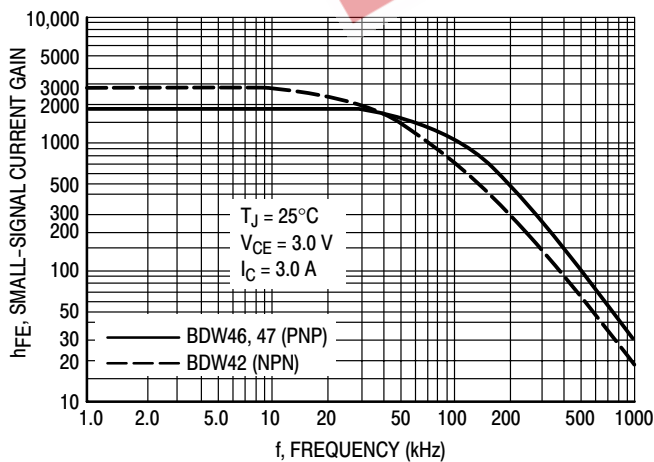

Figure 7. Small-Signal Current Gain

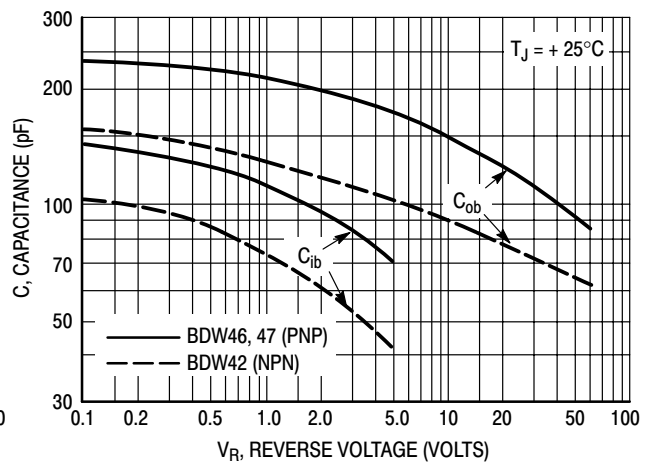

Figure 8. Capacitance

# BDW42 – NPN, BDW46, BDW47 – PNP

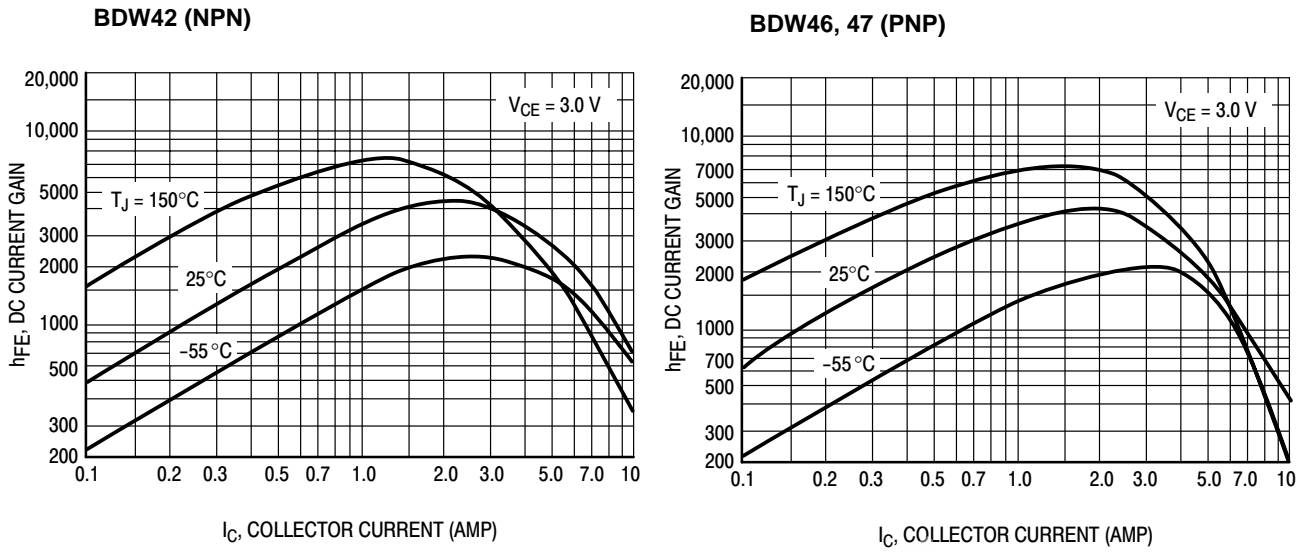

Figure 9. DC Current Gain

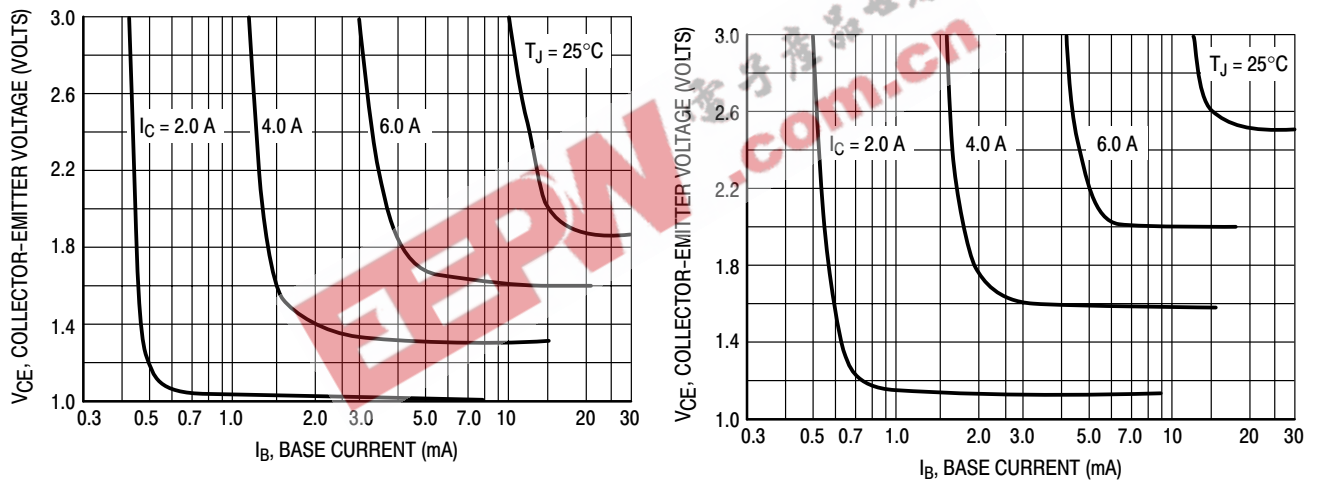

Figure 10. Collector Saturation Region

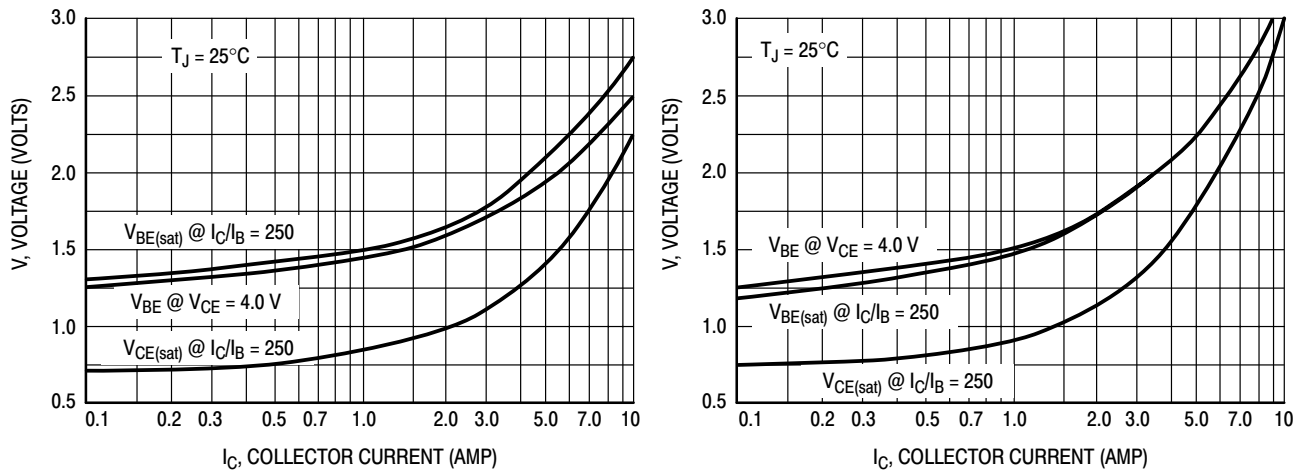

Figure 11. "On" Voltages

# BDW42 – NPN, BDW46, BDW47 – PNP

BDW42 (NPN)

BDW46, 47 (PNP)

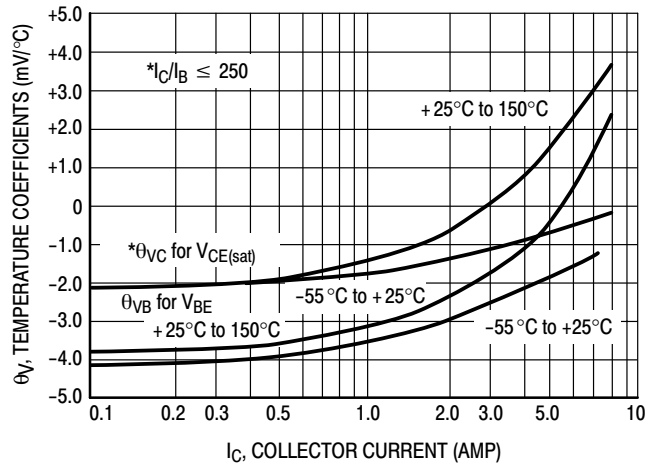
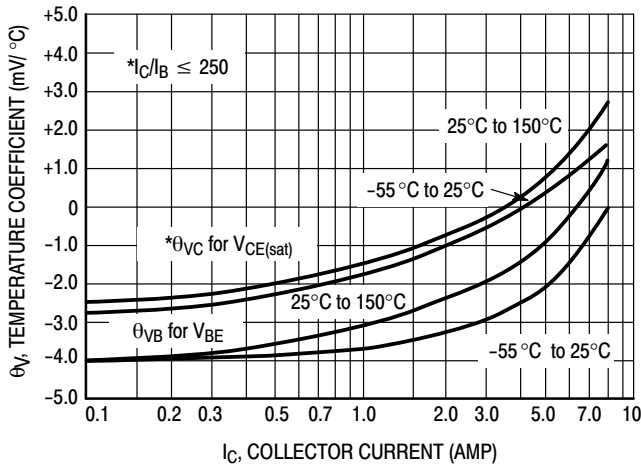

Figure 12. Temperature Coefficients

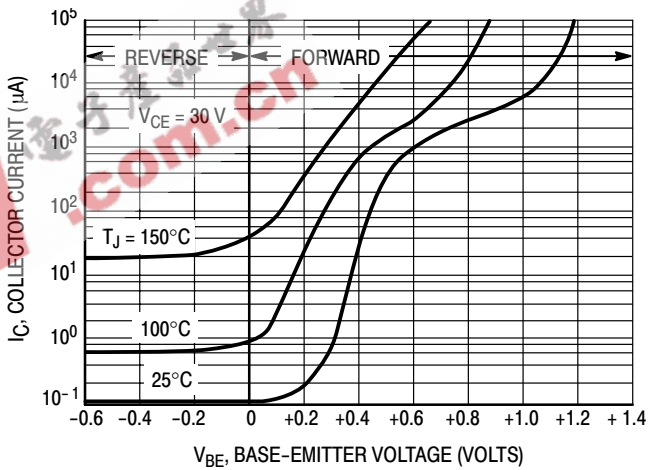
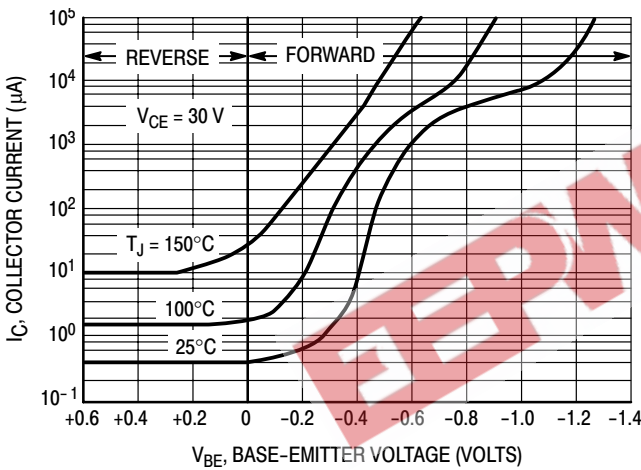

Figure 13. Collector Cut-Off Region

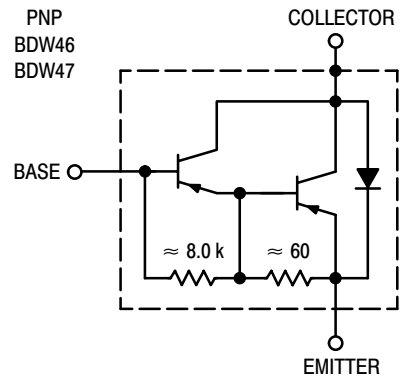
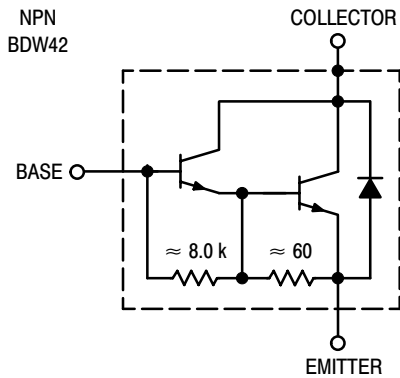
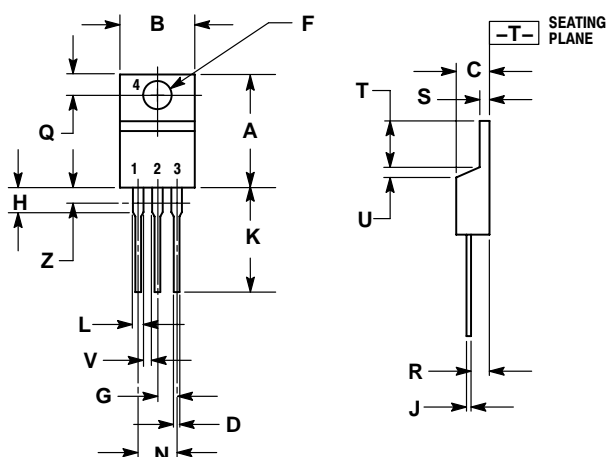

Figure 14. Darlington Schematic

# BDW42 – NPN, BDW46, BDW47 – PNP

## PACKAGE DIMENSIONS

TO-220  
CASE 221A-09  
ISSUE AA



**NOTES:**

1. DIMENSIONING AND TOLERANCING PER ANSI Y14.5M, 1982.
2. CONTROLLING DIMENSION: INCH.
3. DIMENSION Z DEFINES A ZONE WHERE ALL BODY AND LEAD IRREGULARITIES ARE ALLOWED.

DIM	INCHES		MILLIMETERS	
	MIN	MAX	MIN	MAX
A	0.570	0.620	14.48	15.75
B	0.380	0.405	9.66	10.28
C	0.160	0.190	4.07	4.82
D	0.025	0.035	0.64	0.88
F	0.142	0.147	3.61	3.73
G	0.095	0.105	2.42	2.66
H	0.110	0.155	2.80	3.93
J	0.018	0.025	0.46	0.64
K	0.500	0.562	12.70	14.27
L	0.045	0.060	1.15	1.52
N	0.190	0.210	4.83	5.33
Q	0.100	0.120	2.54	3.04
R	0.080	0.110	2.04	2.79
S	0.045	0.055	1.15	1.39
T	0.235	0.255	5.97	6.47
U	0.000	0.050	0.00	1.27
V	0.045	---	1.15	---
Z	---	0.080	---	2.04

**STYLE 1:**

- PIN 1. BASE
- 2. COLLECTOR
- 3. EMITTER
- 4. COLLECTOR

ON Semiconductor and are registered trademarks of Semiconductor Components Industries, LLC (SCILLC). SCILLC reserves the right to make changes without further notice to any products herein. SCILLC makes no warranty, representation or guarantee regarding the suitability of its products for any particular purpose, nor does SCILLC assume any liability arising out of the application or use of any product or circuit, and specifically disclaims any and all liability, including without limitation special, consequential or incidental damages. "Typical" parameters which may be provided in SCILLC data sheets and/or specifications can and do vary in different applications and actual performance may vary over time. All operating parameters, including "Typicals" must be validated for each customer application by customer's technical experts. SCILLC does not convey any license under its patent rights nor the rights of others. SCILLC products are not designed, intended, or authorized for use as components in systems intended for surgical implant into the body, or other applications intended to support or sustain life, or for any other application in which the failure of the SCILLC product could create a situation where personal injury or death may occur. Should Buyer purchase or use SCILLC products for any such unintended or unauthorized application, Buyer shall indemnify and hold SCILLC and its officers, employees, subsidiaries, affiliates, and distributors harmless against all claims, costs, damages, and expenses, and reasonable attorney fees arising out of, directly or indirectly, any claim of personal injury or death associated with such unintended or unauthorized use, even if such claim alleges that SCILLC was negligent regarding the design or manufacture of the part. SCILLC is an Equal Opportunity/Affirmative Action Employer. This literature is subject to all applicable copyright laws and is not for resale in any manner.

### PUBLICATION ORDERING INFORMATION

**LITERATURE FULFILLMENT:**

Literature Distribution Center for ON Semiconductor  
P.O. Box 61312, Phoenix, Arizona 85082-1312 USA  
**Phone:** 480-829-7710 or 800-344-3860 Toll Free USA/Canada  
**Fax:** 480-829-7709 or 800-344-3867 Toll Free USA/Canada  
**Email:** orderlit@onsemi.com

**N. American Technical Support:** 800-282-9855 Toll Free USA/Canada

**Japan:** ON Semiconductor, Japan Customer Focus Center  
2-9-1 Kamimeguro, Meguro-ku, Tokyo, Japan 153-0051  
**Phone:** 81-3-5773-3850

**ON Semiconductor Website:** <http://onsemi.com>

**Order Literature:** <http://www.onsemi.com/litorder>

For additional information, please contact your local Sales Representative.