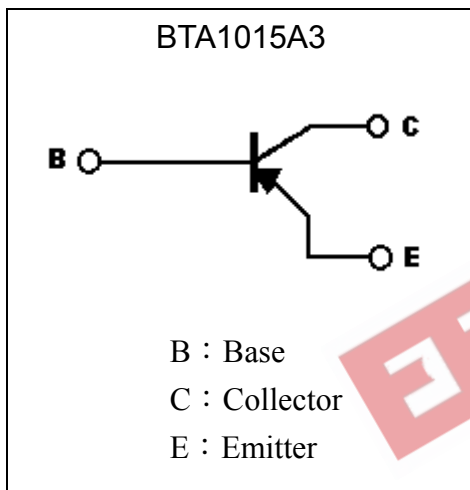
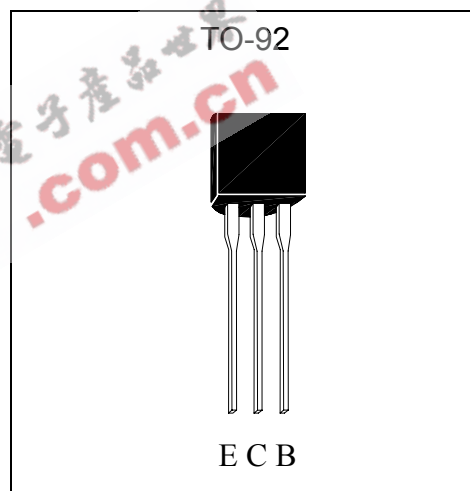

General Purpose PNP Epitaxial Planar Transistor

BTA1015A3

Description

- The BTA1015A3 is designed for use in driver stage of AF amplifier and general purpose amplification.
- High voltage and high current : $V_{CEO} = -50V(\text{min})$, $I_C = -150mA(\text{max})$
- High H_{FE} and excellent linearity
- Complementary to BTC1815A3.

Symbol

Outline

Absolute Maximum Ratings ($T_a = 25^\circ\text{C}$)

Parameter	Symbol	Limits	Unit
Collector-Base Voltage	V_{CBO}	-50	V
Collector-Emitter Voltage	V_{CEO}	-50	V
Emitter-Base Voltage	V_{EBO}	-5	V
Collector Current	I_C	-150	mA
Base Current	I_B	-50	mA
Power Dissipation	P_d	400	mW
Thermal Resistance, Junction to Ambient	$R_{\theta JA}$	250	$^\circ\text{C}/\text{W}$
Junction Temperature	T_j	125	$^\circ\text{C}$
Storage Temperature	T_{stg}	-55~+125	$^\circ\text{C}$



Characteristics (Ta=25°C)

Symbol	Min.	Typ.	Max.	Unit	Test Conditions
BV _{CEO}	-50	-	-	V	I _C =-1mA
I _{CBO}	-	-	-0.1	μA	V _{CB} =-50V
I _{EBO}	-	-	-0.1	μA	V _{EB} =-5V
*V _{CE(sat)}	-	-	-0.3	V	I _C =-100mA, I _B =-10mA
*V _{BE(sat)}	-	-	-1.1	V	I _C =-100mA, I _B =-10mA
h _{FE 1}	70	-	400	-	V _{CE} =-6V, I _C =-2mA
h _{FE 2}	25	80			V _{CE} =-6V, I _C =-150mA
f _T	80	-	-	MHz	V _{CE} =-10V, I _C =-1mA
C _{ob}	-	-	7	pF	V _{CB} =-10V, f=1MHz

*Pulse Test: Pulse Width ≤380μs, Duty Cycle≤2%

Classification Of hFE 1

Rank	O	Y	GR
Range	70~140	120~240	200~400



Characteristic Curves

Current Gain vs Collector Current

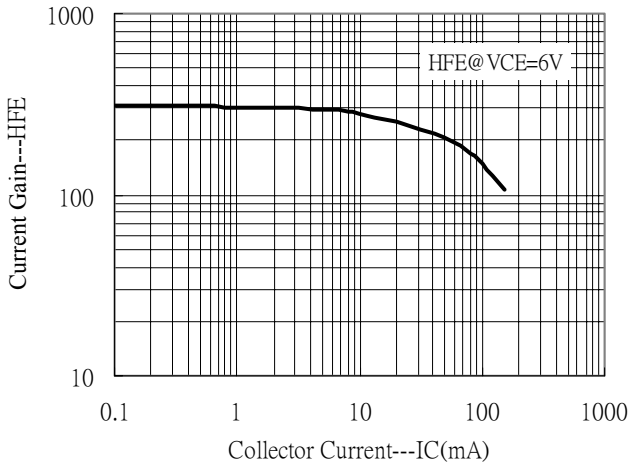

Saturation Voltage vs Collector Current

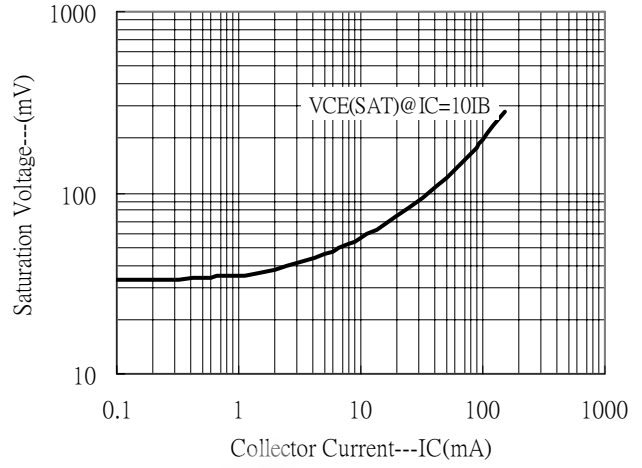

Saturation Voltage vs Collector Current

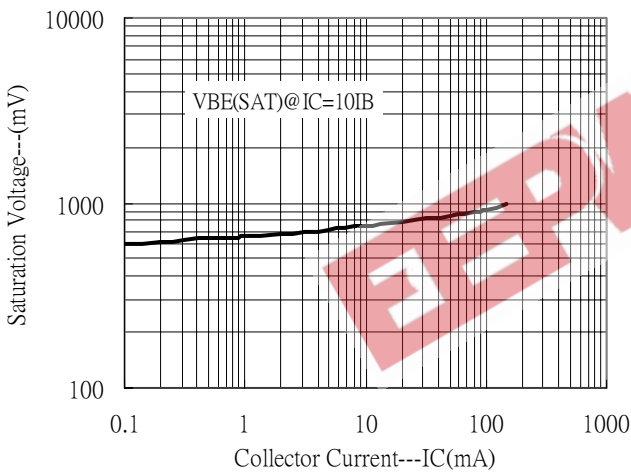

Cutoff Frequency vs Collector Current

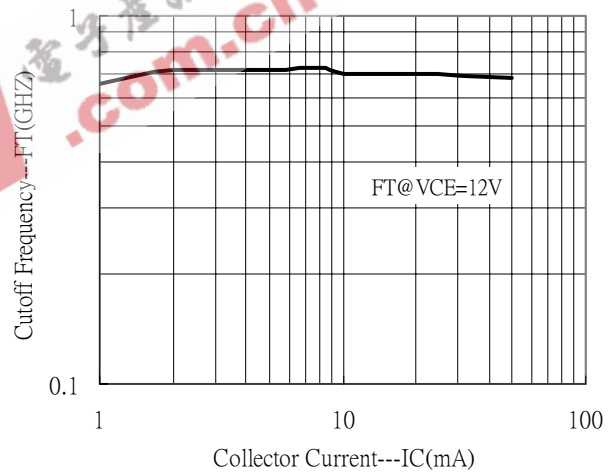

Power Derating Curve

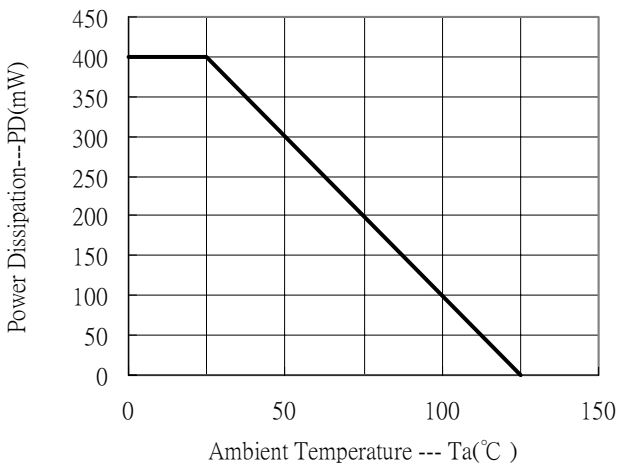

TO-92 Dimension

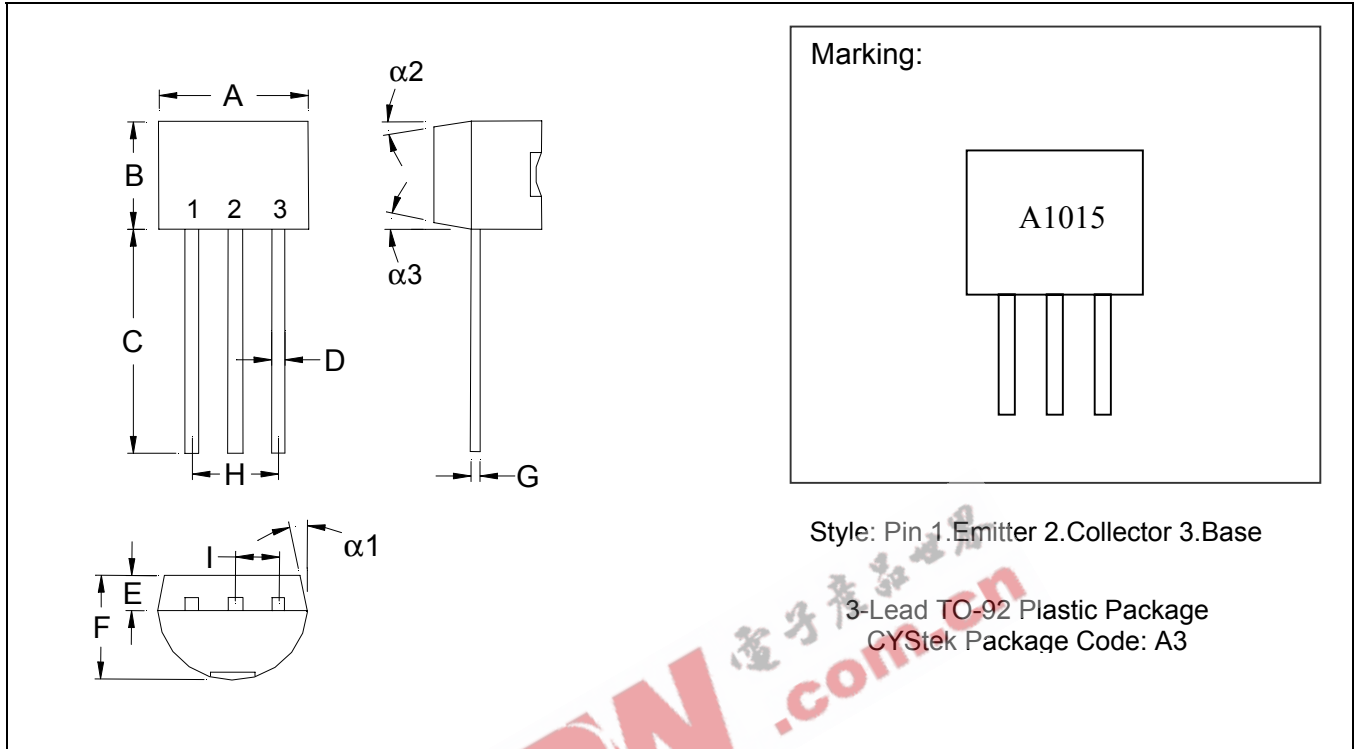

*: Typical

DIM	Inches		Millimeters		DIM	Inches		Millimeters	
	Min.	Max.	Min.	Max.		Min.	Max.	Min.	Max.
A	0.1704	0.1902	4.33	4.83	G	0.0142	0.0220	0.36	0.56
B	0.1704	0.1902	4.33	4.83	H	-	*0.1000	-	*2.54
C	0.5000	-	12.70	-	I	-	*0.0500	-	*1.27
D	0.0142	0.0220	0.36	0.56	$\alpha 1$	-	*5°	-	*5°
E	-	*0.0500	-	*1.27	$\alpha 2$	-	*2°	-	*2°
F	0.1323	0.1480	3.36	3.76	$\alpha 3$	-	*2°	-	*2°

- Notes: 1. Controlling dimension: millimeters.
 2. Maximum lead thickness includes lead finish thickness, and minimum lead thickness is the minimum thickness of base material.
 3. If there is any question with packing specification or packing method, please contact your local CYStek sales office.

Material:

- Lead: 42 Alloy ; solder plating
- Mold Compound: Epoxy resin family, flammability solid burning class: UL94V-0

Important Notice:

- All rights are reserved. Reproduction in whole or in part is prohibited without the prior written approval of CYStek.
- CYStek reserves the right to make changes to its products without notice.
- CYStek **semiconductor products are not warranted to be suitable for use in Life-Support Applications, or systems.**
- CYStek assumes no liability for any consequence of customer product design, infringement of patents, or application assistance.