



# BTA/BTB08 and T8 Series

SNUBBERLESS™, LOGIC LEVEL & STANDARD

8A TRIACs

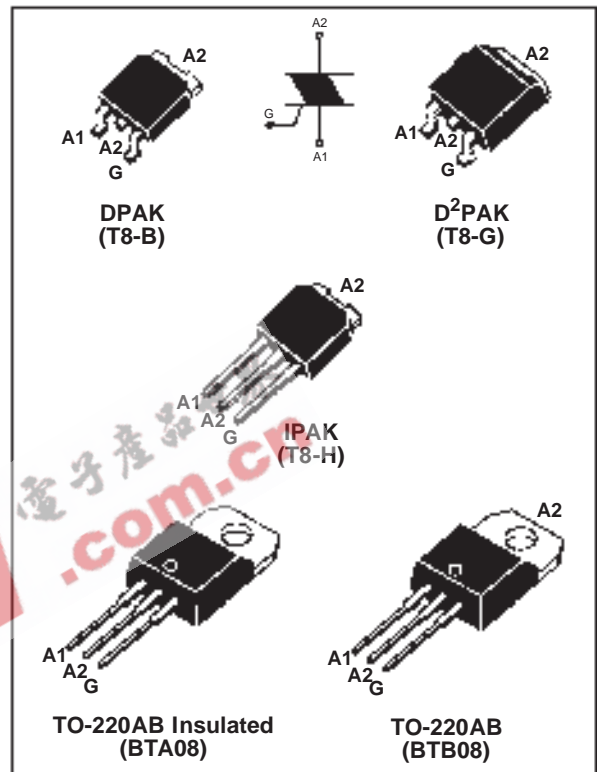
## MAIN FEATURES:

Symbol	Value	Unit
$I_{T(RMS)}$	8	A
$V_{DRM}/V_{RRM}$	600 and 800	V
$I_{GT}(Q_1)$	5 to 50	mA

## DESCRIPTION

Available either in through-hole or surface-mount packages, the BTA/BTB08 and T8 triac series is suitable for general purpose AC switching. They can be used as an ON/OFF function in applications such as static relays, heating regulation, induction motor starting circuits... or for phase control operation in light dimmers, motor speed controllers,...

The snubberless versions (BTA/BTB...W and T8 series) are specially recommended for use on inductive loads, thanks to their high commutation performances. By using an internal ceramic pad, the BTA series provides voltage insulated tab (rated at 2500V RMS) complying with UL standards (File ref.: E81734)



## ABSOLUTE MAXIMUM RATINGS

Symbol	Parameter	Value	Unit	
$I_{T(RMS)}$	RMS on-state current (full sine wave)	DPAK / D PAK IPAK / TO-220AB $T_c = 110^\circ\text{C}$	8	A
		TO-220AB Ins. $T_c = 100^\circ\text{C}$		
$I_{TSM}$	Non repetitive surge peak on-state current (full cycle, $T_j$ initial = $25^\circ\text{C}$ )	F = 50 Hz t = 20 ms	80	A
		F = 60 Hz t = 16.7 ms		
$I_t$	$I_t$ Value for fusing	tp = 10 ms	45	A s
dI/dt	Critical rate of rise of on-state current $I_G = 2 \times I_{GT}$ , tr ≤ 100 ns	F = 120 Hz $T_j = 125^\circ\text{C}$	50	A/μs
$I_{GM}$	Peak gate current	tp = 20 μs $T_j = 125^\circ\text{C}$	4	A
$P_{G(AV)}$	Average gate power dissipation	$T_j = 125^\circ\text{C}$	1	W
$T_{stg}$ $T_j$	Storage junction temperature range Operating junction temperature range		- 40 to + 150 - 40 to + 125	$^\circ\text{C}$

## BTA/BTB08 and T8 Series

### ELECTRICAL CHARACTERISTICS (T<sub>j</sub> = 25°C, unless otherwise specified)

#### ■ SNUBBERLESS™ and LOGIC LEVEL (3 Quadrants)

Symbol	Test Conditions	Quadrant		T8		BTA/BTB08				Unit
				T810	T835	TW	SW	CW	BW	
I <sub>GT</sub> (1)	V <sub>D</sub> = 12 V    R <sub>L</sub> = 30 Ω	I - II - III	MAX.	10	35	5	10	35	50	mA
V <sub>GT</sub>			MAX.	1.3						
V <sub>GD</sub>	V <sub>D</sub> = V <sub>DRM</sub> R <sub>L</sub> = 3.3 kΩ T <sub>j</sub> = 125°C	I - II - III	MIN.	0.2						V
I <sub>H</sub> (2)	I <sub>T</sub> = 100 mA	I - III II	MAX.	15	35	10	15	35	50	mA
I <sub>L</sub>	I <sub>G</sub> = 1.2 I <sub>GT</sub>		MAX.	25	50	10	25	50	70	
				30	60	15	30	60	80	
dV/dt (2)	V <sub>D</sub> = 67 %V <sub>DRM</sub> gate open T <sub>j</sub> = 125°C		MIN.	40	400	20	40	400	1000	V/μs
(di/dt) <sub>c</sub> (2)	(dV/dt) <sub>c</sub> = 0.1 V/μs    T <sub>j</sub> = 125°C		MIN.	5.4	-	3.5	5.4	-	-	A/ms
	(dV/dt) <sub>c</sub> = 10 V/μs    T <sub>j</sub> = 125°C			2.8	-	1.5	2.8	-	-	
	Without snubber    T <sub>j</sub> = 125°C			-	4.5	-	-	4.5	7	

#### ■ STANDARD (4 Quadrants)

Symbol	Test Conditions	Quadrant		BTA/BTB08		Unit
				C	B	
I <sub>GT</sub> (1)	V <sub>D</sub> = 12 V    R <sub>L</sub> = 30 Ω	I - II - III IV	MAX.	25	50	mA
V <sub>GT</sub>			ALL	50	100	
V <sub>GD</sub>	V <sub>D</sub> = V <sub>DRM</sub> R <sub>L</sub> = 3.3 kΩ    T <sub>j</sub> = 125°C	ALL	MIN.	0.2		V
I <sub>H</sub> (2)	I <sub>T</sub> = 500 mA		MAX.	25	50	mA
I <sub>L</sub>	I <sub>G</sub> = 1.2 I <sub>GT</sub>	I - III - IV	MAX.	40	50	
		II		80	100	
dV/dt (2)	V <sub>D</sub> = 67 %V <sub>DRM</sub> gate open    T <sub>j</sub> = 125°C		MIN.	200	400	V/μs
(dV/dt) <sub>c</sub> (2)	(di/dt) <sub>c</sub> = 3.5 A/ms    T <sub>j</sub> = 125°C		MIN.	5	10	V/μs

### STATIC CHARACTERISTICS

Symbol	Test Conditions	Value	Unit
V <sub>TM</sub> (2)	I <sub>TM</sub> = 11 A    t <sub>p</sub> = 380 μs	T <sub>j</sub> = 25°C    MAX.	1.55    V
V <sub>to</sub> (2)	Threshold voltage	T <sub>j</sub> = 125°C    MAX.	0.85    V
R <sub>d</sub> (2)	Dynamic resistance	T <sub>j</sub> = 125°C    MAX.	50    mΩ
I <sub>DRM</sub>	V <sub>DRM</sub> = V <sub>RRM</sub>	T <sub>j</sub> = 25°C	5    μA
I <sub>RRM</sub>		T <sub>j</sub> = 125°C	MAX.    1    mA

**Note 1:** minimum I<sub>GT</sub> is guaranteed at 5% of I<sub>GT</sub> max.

**Note 2:** for both polarities of A2 referenced to A1

**THERMAL RESISTANCES**

Symbol	Parameter		Value	Unit			
R <sub>th(j-c)</sub>	Junction to case (AC)		DPAK / D PAK IPAK / TO-220AB	1.6	°C/W		
			TO-220AB Insulated			2.5	
R <sub>th(j-a)</sub>	Junction to ambient		S = 1 cm	D PAK	45	°C/W	
			S = 0.5 cm		DPAK		70
					TO-220AB TO-220AB Insulated		60
					IPAK		100

S = Copper surface under tab

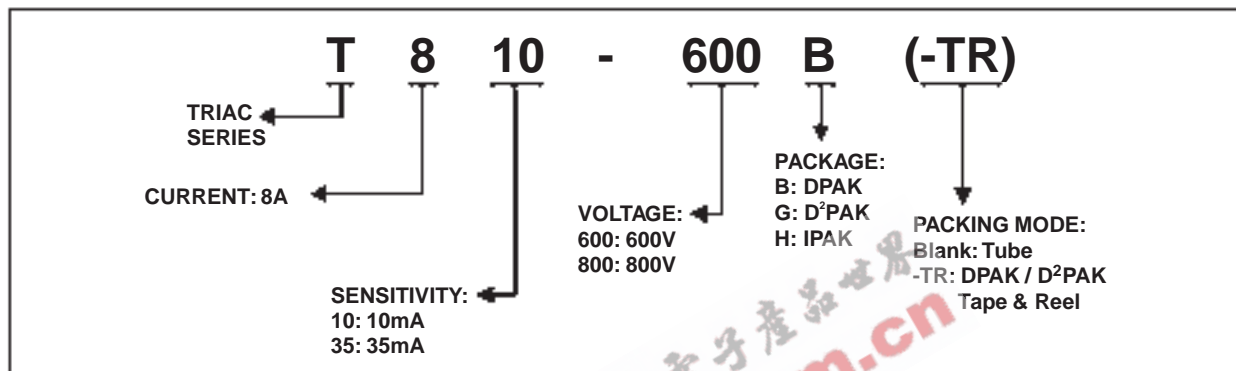
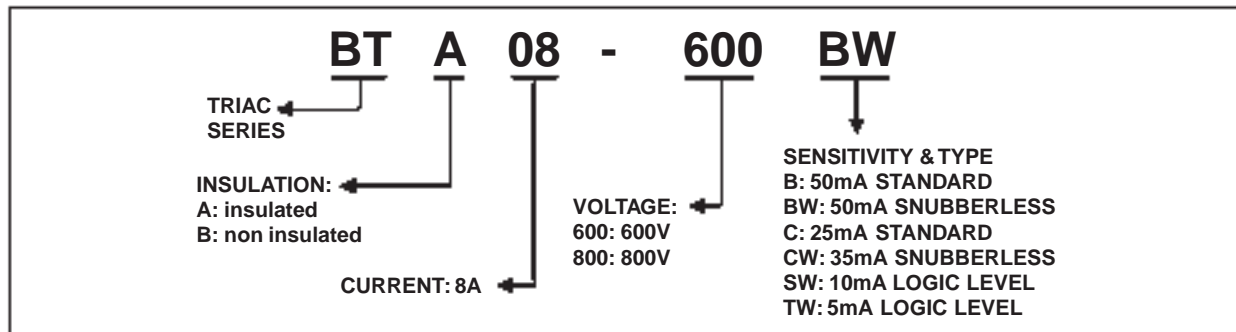
**PRODUCT SELECTOR**

Part Number	Voltage (xxx)		Sensitivity	Type	Package
	600 V	800 V			
BTA/BTB08-xxxB	X	X	50 mA	Standard	TO-220AB
BTA/BTB108-xxxBW	X	X	50 mA	Snubberless	TO-220AB
BTA/BTB08-xxxC	X	X	25 mA	Standard	TO-220AB
BTA/BTB08-xxxCW	X	X	35 mA	Snubberless	TO-220AB
BTA/BTB08-xxxSW	X	X	10 mA	Logic level	TO-220AB
BTA/BTB08-xxxTW	X	X	5 mA	Logic level	TO-220AB
T810-xxxB	X	X	10 mA	Logic level	DPAK
T810-xxxH	X	X	10 mA	Logic level	IPAK
T835-xxxB	X	X	35mA	Snubberless	DPAK
T835-xxxG	X	X	35 mA	Snubberless	D PAK
T835-xxxH	X	X	35 mA	Snubberless	IPAK

BTB: non insulated TO-220AB package

## BTA/BTB08 and T8 Series

### ORDERING INFORMATION

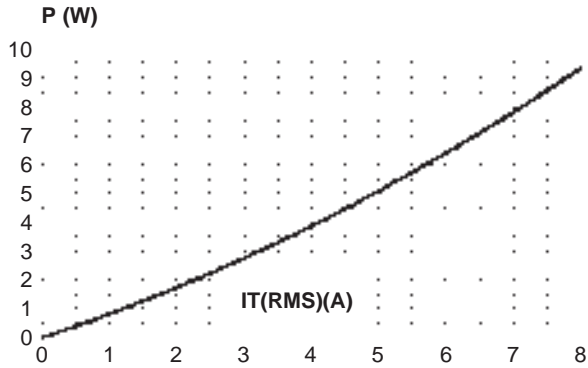


### OTHER INFORMATION

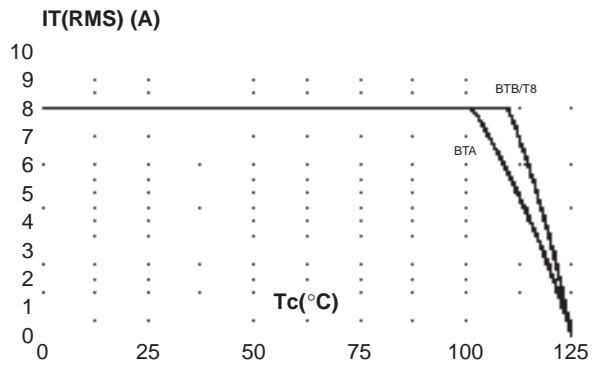
Part Number	Marking	Weight	Base quantity	Packing mode
BTA/BTB08-xxxzy	BTA/BTB08xxxzy	2.3 g	250	Bulk
T8yy-xxxB	T8yyxxx	0.3 g	75	Tube
T8yy-xxxB-TR	T8yyxxx	0.3 g	2500	Tape & reel
T8yy-xxxH	T8yyxxx	0.4 g	75	Tube
T8yy-xxxG	T8yyxxx	1.5 g	50	Tube
T8yy-xxxG-TR	T8yyxxx	1.5 g	1000	Tape & reel

Note: xxx = voltage, yy = sensitivity, z = type

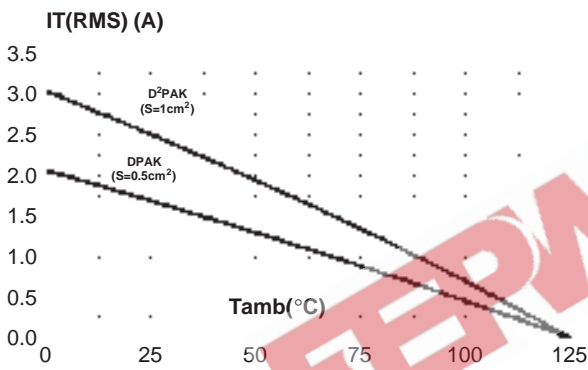
**Fig. 1:** Maximum power dissipation versus RMS on-state current (full cycle).



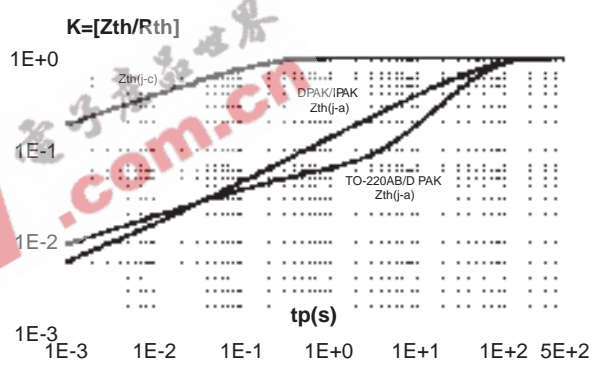
**Fig. 2-1:** RMS on-state current versus case temperature (full cycle).



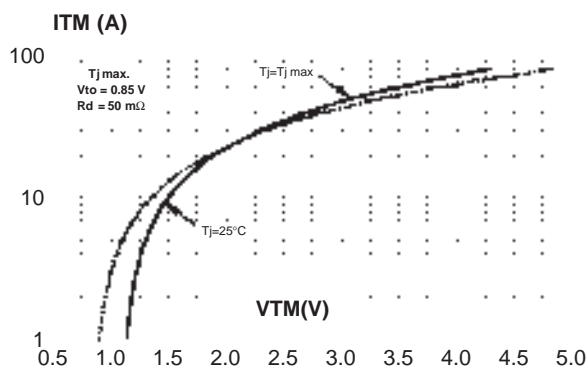
**Fig. 2-2:** RMS on-state current versus ambient temperature (printed circuit board FR4, copper thickness: 35µm), full cycle.



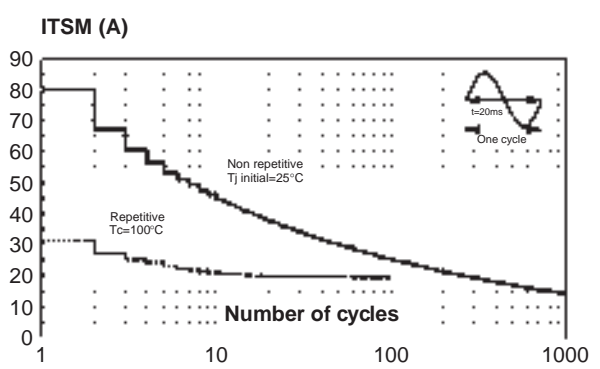
**Fig. 3:** Relative variation of thermal impedance versus pulse duration.



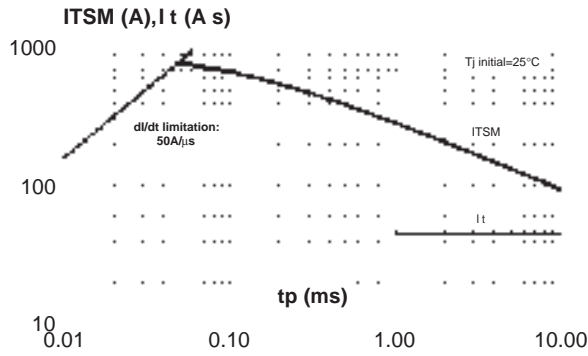
**Fig. 4:** On-state characteristics (maximum values).



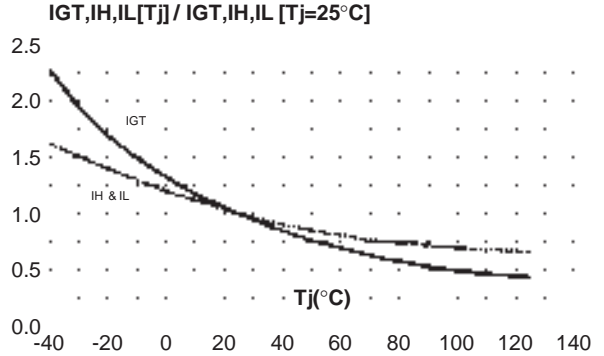
**Fig. 5:** Surge peak on-state current versus number of cycles.



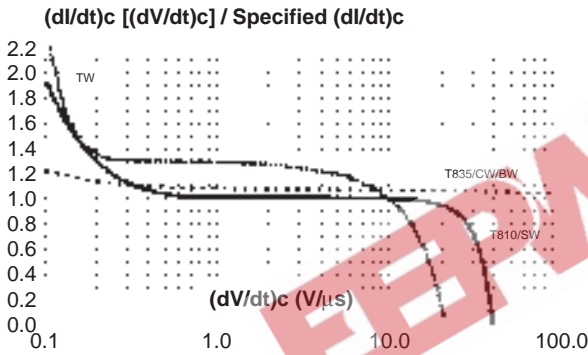
**Fig. 6:** Non-repetitive surge peak on-state current for a sinusoidal pulse with width  $t_p < 10\text{ms}$ , and corresponding value of  $I_t$ .



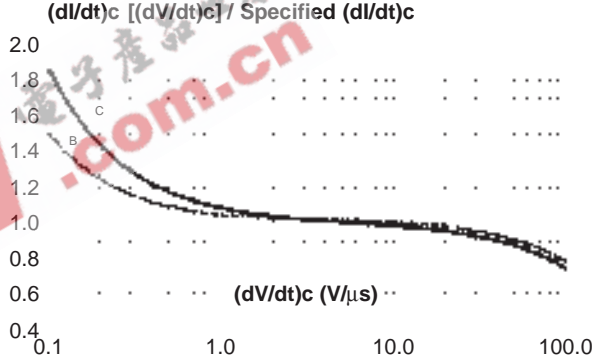
**Fig. 7:** Relative variation of gate trigger current, holding current and latching current versus junction temperature (typical values).



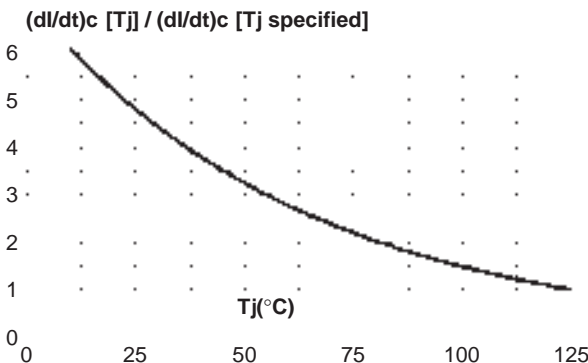
**Fig. 8-1:** Relative variation of critical rate of decrease of main current versus  $(dV/dt)_c$  (typical values). Snubberless & Logic Level Types



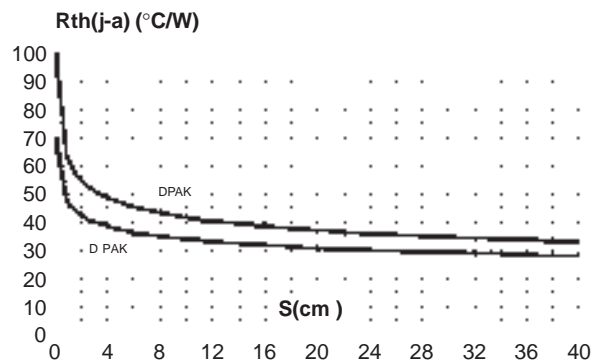
**Fig. 8-2:** Relative variation of critical rate of decrease of main current versus  $(dV/dt)_c$  (typical values). Standard Types



**Fig. 9:** Relative variation of critical rate of decrease of main current versus junction temperature.

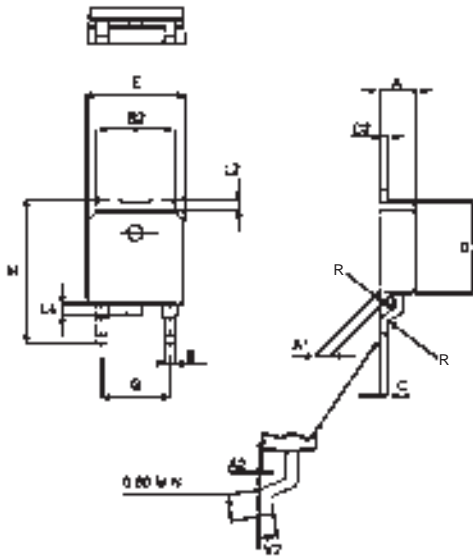


**Fig. 10:** DPAK and D<sup>2</sup>PAK Thermal resistance junction to ambient versus copper surface under tab (printed circuit board FR4, copper thickness: 35 μm).



**PACKAGE MECHANICAL DATA**

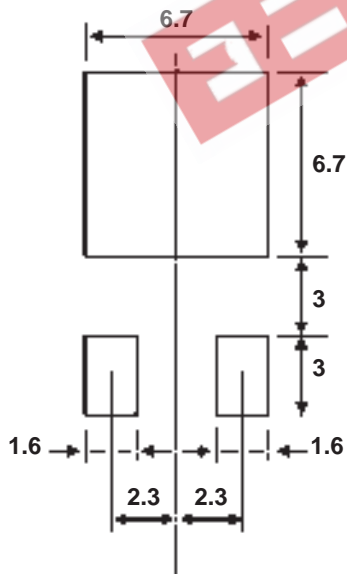
DPAK (Plastic)



REF.	DIMENSIONS			
	Millimeters		Inches	
	Min.	Max.	Min.	Max.
A	2.20	2.40	0.086	0.094
A1	0.90	1.10	0.035	0.043
A2	0.03	0.23	0.001	0.009
B	0.64	0.90	0.025	0.035
B2	5.20	5.40	0.204	0.212
C	0.45	0.60	0.017	0.023
C2	0.48	0.60	0.018	0.023
D	6.00	6.20	0.236	0.244
E	6.40	6.60	0.251	0.259
G	4.40	4.60	0.173	0.181
H	9.35	10.10	0.368	0.397
L2	0.80 typ.		0.031 typ.	
L4	0.60	1.00	0.023	0.039
R	0.2 typ.		0.007 typ.	
V2	0°	8°	0°	8°

**FOOTPRINT DIMENSIONS (in millimeters)**

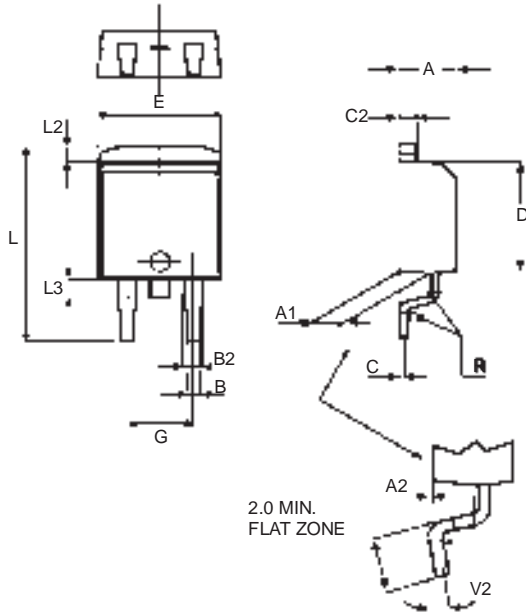
DPAK (Plastic)



## BTA/BTB08 and T8 Series

### PACKAGE MECHANICAL DATA

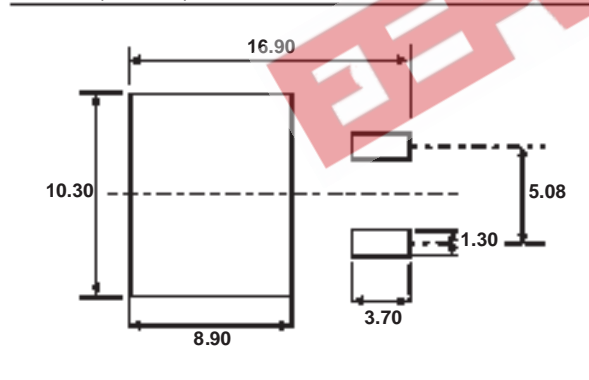
D PAK (Plastic)



REF.	DIMENSIONS					
	Millimeters			Inches		
	Min.	Typ.	Max.	Min.	Typ.	Max.
A	4.30		4.60	0.169		0.181
A1	2.49		2.69	0.098		0.106
A2	0.03		0.23	0.001		0.009
B	0.70		0.93	0.027		0.037
B2	1.25	1.40		0.048	0.055	
C	0.45		0.60	0.017		0.024
C2	1.21		1.36	0.047		0.054
D	8.95		9.35	0.352		0.368
E	10.00		10.28	0.393		0.405
G	4.88		5.28	0.192		0.208
L	15.00		15.85	0.590		0.624
L2	1.27		1.40	0.050		0.055
L3	1.40		1.75	0.055		0.069
R		0.40			0.016	
V2	0°		8°	0°		8°

### FOOTPRINT DIMENSIONS (in millimeters)

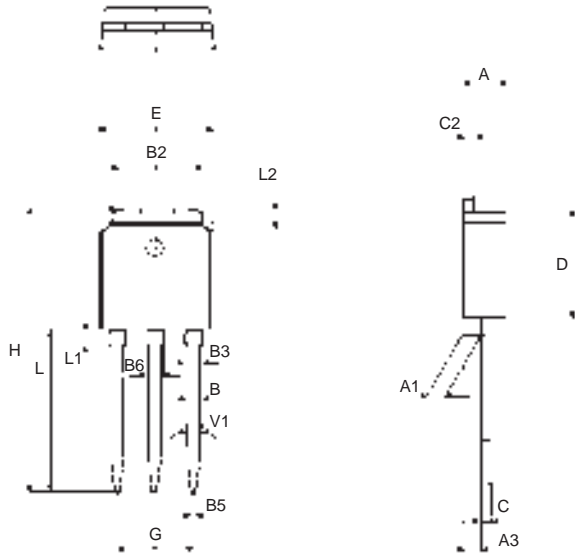
D PAK (Plastic)





PACKAGE MECHANICAL DATA

IPAK (Plastic)

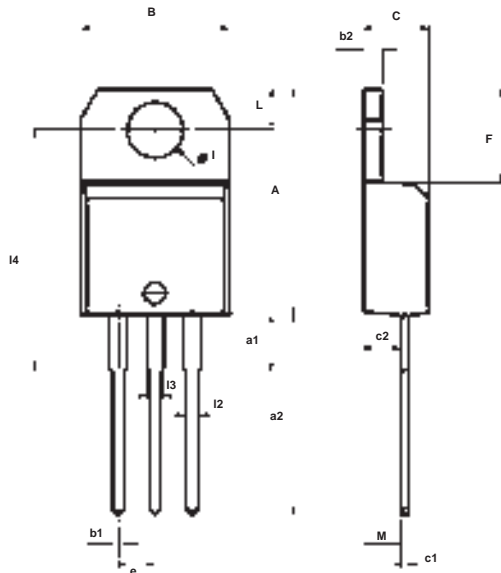


REF.	DIMENSIONS					
	Millimeters			Inches		
	Min.	Typ.	Max.	Min.	Typ.	Max.
A	2.2		2.4	0.086		0.094
A1	0.9		1.1	0.035		0.043
A3	0.7		1.3	0.027		0.051
B	0.64		0.9	0.025		0.035
B2	5.2		5.4	0.204		0.212
B3			0.85			0.033
B5		0.3			0.035	
B6			0.95			0.037
C	0.45		0.6	0.017		0.023
C2	0.48		0.6	0.019		0.023
D	6		6.2	0.236		0.244
E	6.4		6.6	0.252		0.260
G	4.4		4.6	0.173		0.181
H	15.9		16.3	0.626		0.641
L	9		9.4	0.354		0.370
L1	0.8		1.2	0.031		0.047
L2		0.8	1		0.031	0.039
V1		10°			10°	

## BTA/BTB08 and T8 Series

### PACKAGE MECHANICAL DATA

TO-220AB Ins.



REF.	DIMENSIONS					
	Millimeters			Inches		
	Min.	Typ.	Max.	Min.	Typ.	Max.
A	15.20		15.90	0.598		0.625
a1		3.75			0.147	
a2	13.00		14.00	0.511		0.551
B	10.00		10.40	0.393		0.409
b1	0.61		0.88	0.024		0.034
b2	1.23		1.32	0.048		0.051
C	4.40		4.60	0.173		0.181
c1	0.49		0.70	0.019		0.027
c2	2.40		2.72	0.094		0.107
e	2.40		2.70	0.094		0.106
F	6.20		6.60	0.244		0.259
I	3.75		3.85	0.147		0.151
I4	15.80	16.40	16.80	0.622	0.646	0.661
L	2.65		2.95	0.104		0.116
l2	1.14		1.70	0.044		0.066
l3	1.14		1.70	0.044		0.066
M		2.60			0.102	

Information furnished is believed to be accurate and reliable. However, STMicroelectronics assumes no responsibility for the consequences of use of such information nor for any infringement of patents or other rights of third parties which may result from its use. No license is granted by implication or otherwise under any patent or patent rights of STMicroelectronics. Specifications mentioned in this publication are subject to change without notice. This publication supersedes and replaces all information previously supplied. STMicroelectronics products are not authorized for use as critical components in life support devices or systems without express written approval of STMicroelectronics.

© The ST logo is a registered trademark of STMicroelectronics

© 2000 STMicroelectronics - Printed in Italy - All Rights Reserved

STMicroelectronics GROUP OF COMPANIES  
 Australia - Brazil - China - Finland - France - Germany - Hong Kong - India - Italy - Japan - Malaysia - Malta - Morocco  
 Singapore - Spain - Sweden - Switzerland - United Kingdom

<http://www.st.com>