

## High-Speed CMOS Logic CMOS Programmable Divide-by-N Counter

### Features

- Synchronous Programmable ÷N Counter N = 3 to 9999 or 15999
- Presetable Down-Counter
- Fully Static Operation
- Mode-Select Control of Initial Decade Counting Function (÷10, 8, 5, 4, 2)
- Master Preset Initialization
- Latchable ÷N Output
- Fanout (Over Temperature Range)
  - Standard Outputs . . . . . 10 LSTTL Loads
  - Bus Driver Outputs . . . . . 15 LSTTL Loads
- Wide Operating Temperature Range . . . -55°C to 125°C
- Balanced Propagation Delay and Transition Times
- Significant Power Reduction Compared to LSTTL Logic ICs
- HC Types
  - 2V to 6V Operation
  - High Noise Immunity:  $N_{IL} = 30\%$ ,  $N_{IH} = 30\%$  of  $V_{CC}$  at  $V_{CC} = 5V$

### Applications

- Communications Digital Frequency Synthesizers; VHF, UHF, FM, AM, etc.
- Fixed or Programmable Frequency Division
- "Time Out" Timer for Consumer-Application Industrial Controls

### Ordering Information

PART NUMBER	TEMP. RANGE (°C)	PACKAGE
CD54HC4059F3A	-55 to 125	24 Ld CERDIP
CD74HC4059E	-55 to 125	24 Ld PDIP
CD74HC4059M96	-55 to 125	24 Ld SOIC

NOTE: When ordering, use the entire part number. The suffix 96 denotes tape and reel.

### Description

The 'HC4059 are high-speed silicon-gate devices that are pin-compatible with the CD4059A devices of the CD4000B series. These devices are divide-by-N down-counters that can be programmed to divide an input frequency by any number "N" from 3 to 15,999. The output signal is a pulse one clock cycle wide occurring at a rate equal to the input frequency divide by N. The down-counter is preset by means of 16 jam inputs.

The three Mode-Select Inputs  $K_a$ ,  $K_b$  and  $K_c$  determine the modulus ("divide-by" number) of the first and last counting sections in accordance with the truth table. Every time the first (fastest) counting section goes through one cycle, it reduces by 1 the number that has been preset (jammed) into the three decades of the intermediate counting section and the last counting section, which consists of flip-flops that are not needed for opening the first counting section. For example, in the ÷2 mode, only one flip-flop is needed in the first counting section. Therefore the last counting section has three flip-flops that can be preset to a maximum count of seven with a place value of thousands. If ÷10 is desired for the first section,  $K_a$  is set "high",  $K_b$  "high" and  $K_c$  "low". Jam inputs J1, J2, J3, and J4 are used to preset the first counting section and there is no last counting section. The intermediate counting section consists of three cascaded BCD decade (÷10) counters presettable by means of Jam Inputs J5 through J16.

The Mode-Select Inputs permit frequency-synthesizer channel separations of 10, 12.5, 20, 25 or 50 parts. These inputs set the maximum value of N at 9999 (when the first counting section divides by 5 or 10) or 15,999 (when the first counting section divides by 8, 4, or 2).

The three decades of the intermediate counter can be preset to a binary 15 instead of a binary 9, while their place values are still 1, 10, and 100, multiplied by the number of the ÷N mode. For example, in the ÷8 mode, the number from which counting down begins can be preset to:

3rd Decade	1500
2nd Decade	150
1st Decade	15
Last Counting Section	1000

The total of these numbers (2665) times 8 equals 12,320. The first counting section can be preset to 7. Therefore, 21,327 is the maximum possible count in the ÷8 mode.

The highest count of the various modes is shown in the Extended Counter Range column. Control inputs  $K_b$  and  $K_c$  can be used to initiate and lock the counter in the "master preset" state. In this condition the flip-flops in the counter are preset in accordance with the jam inputs and the counter remains in that state as long as  $K_b$  and  $K_c$  both remain low. The counter begins to count down from the preset state when a counting mode other than the master preset mode is selected.

## CD54HC4059, CD74HC4059

The counter should always be put in the master preset mode before the ÷5 mode is selected. Whenever the master preset mode is used, control signals  $K_b = \text{"low"}$  and  $K_c = \text{"low"}$  must be applied for at least 3 full clock pulses.

After Preset Mode inputs have been changed to one of the ÷ modes, the next positive-going clock transition changes an internal flip-flop so that the countdown can begin at the second positive-going clock transition. Thus, after an MP (Master Preset) mode, there is always one extra count before the output goes high. Figure 1 illustrates a total count of 3 (÷8 mode). If the Master Preset mode is started two clock cycles or less before an output pulse, the output pulse will appear at the time due. If the Master Preset Mode is not used, the counter jumps back to the "Jam" count when the output pulse appears.

A "high" on the Latch Enable input will cause the counter output to remain high once an output pulse occurs, and to remain in the high state until the latch input returns to "low". If the Latch Enable is "low", the output pulse will remain high for only one cycle of the clock-input signal.

### Pinout

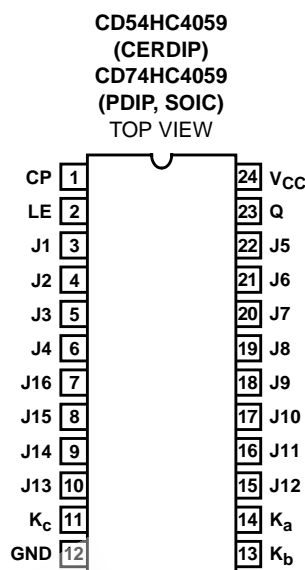

### Functional Diagram

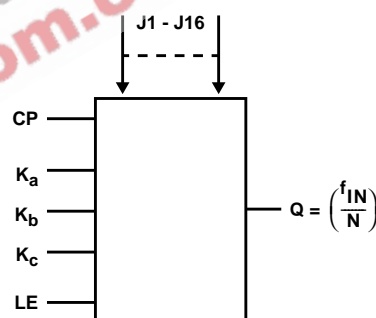

TRUTH TABLE

MODE SELECT INPUT			FIRST COUNTING SECTION			LAST COUNTING SECTION			COUNTER RANGE	
									DESIGN	EXTENDED
$K_a$	$K_b$	$K_c$	MODE DIVIDES-BY	CAN BE PRESET TO A MAX OF:	(NOTE 1) JAM INPUTS USED:	MODE DIVIDES-BY	CAN BE PRESET TO A MAX OF:	(NOTE 1) JAM INPUTS USED:	MAX	MAX
H	H	H	2	1	J1	8	7	J2, J3, J4	15,999	17,331
L	H	H	4	3	J1, J2	4	3	J3, J4	15,999	18,663
H	L	H	5 (Note 2)	4	J1, J2, J3	2	1	J4	9,999	13,329
L	L	H	8	7	J1, J2, J3	2	1	J4	15,999	21,327
H	H	L	10	9	J1, J2, J3, J4	1	0	-	9,999	16,659
X	L	L	Master Preset			Master Preset			-	-

X = Don't care

NOTES:

1. J1 = Least Significant Bit. J4 = Most Significant Bit.
2. Operation in the ÷5 mode (1st counting section) requires going through the Master Preset mode prior to going into the ÷5 mode. At power turn-on,  $K_c$  must be "low" for a period of 3 input clock pulses after VCC reaches a minimum of 3V.

## CD54HC4059, CD74HC4059

### How to Preset the HC/HCT4059 to Desired ÷N

The value N is determined as follows:

(EQ. 1)

$$N = (\text{MODE}^\dagger) (1000 \times \text{Decade 5 Preset} + 100 \times \text{Decade 4 Preset} + 10 \times \text{Decade 3 Preset} + 1 \times \text{Decade 2 Preset}) + \text{Decade 1 Preset}$$

† MODE = First counting section divider (10, 8, 5, 4 or 2)

$$\text{Preset Value} = \frac{N}{\text{Mode}} \quad (\text{EQ. 2})$$

Example:  
N = 8479, Mode = 5

Mode Select = 5  
 $\begin{matrix} K_a & K_b & K_c \\ H & L & H \end{matrix}$

$$\begin{array}{r} 1695 + 4 \text{ (Preset Values)} \\ 5 \overline{) 8479} \\ \underline{5} \phantom{00} \\ 3 \phantom{00} \\ \underline{30} \phantom{00} \\ 7 \phantom{00} \\ \underline{70} \phantom{00} \\ 9 \phantom{00} \\ \underline{90} \phantom{00} \\ 9 \phantom{00} \\ \underline{90} \phantom{00} \\ 0 \phantom{00} \end{array}$$

Mode ←      ← N

To calculate preset values for any N count, divide the N count by the Mode. The resultant is the corresponding preset values of the 5th through 2nd decade with the remainder being equal to the 1st decade value.

#### Program Jam Inputs (BCD)

4				1	5				9				6			
J1	J2	J3	J4		J5	J6	J7	J8	J9	J10	J11	J12	J13	J14	J15	J16
L	L	H	H		H	L	H	L	H	L	L	H	L	H	H	L

NOTE: To verify the results, use Equation 1:  
 $N = 5 (1000 \times 1 + 100 \times 6 + 10 \times 9 + 1 \times 5) + 4$   
 $N = 8479$

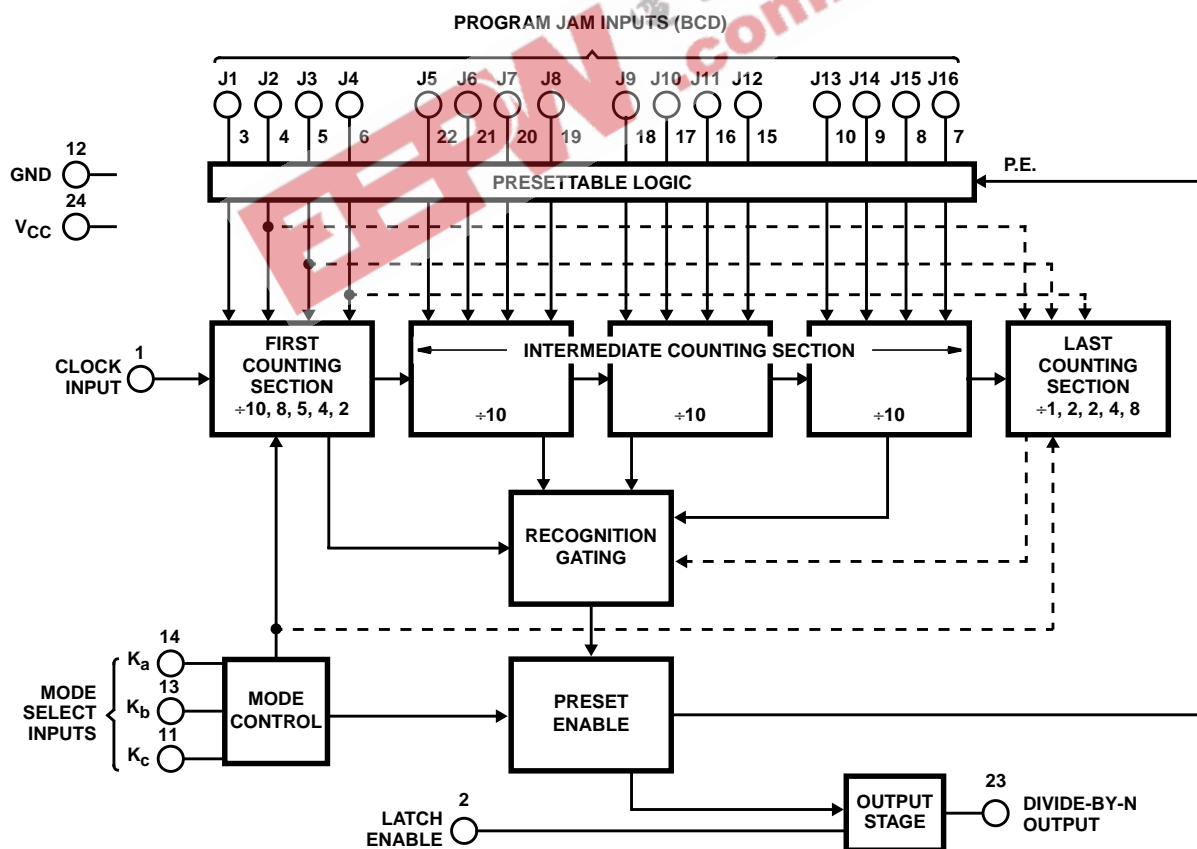

FIGURE 1. FUNCTIONAL BLOCK DIAGRAM

## CD54HC4059, CD74HC4059

### Absolute Maximum Ratings

DC Supply Voltage, $V_{CC}$ .....	-0.5V to 7V
DC Input Diode Current, $I_{IK}$	
For $V_I < -0.5V$ or $V_I > V_{CC} + 0.5V$ .....	$\pm 20mA$
DC Output Diode Current, $I_{OK}$	
For $V_O < -0.5V$ or $V_O > V_{CC} + 0.5V$ .....	$\pm 20mA$
DC Output Source or Sink Current per Output Pin, $I_O$	
For $V_O > -0.5V$ or $V_O < V_{CC} + 0.5V$ .....	$\pm 25mA$
DC $V_{CC}$ or Ground Current, $I_{CC}$ .....	$\pm 50mA$

### Thermal Information

Thermal Resistance (Typical)	$\theta_{JA}$ ( $^{\circ}C/W$ )
E (PDIP) Package (Note 3) .....	67
M (SOIC) Package (Note 4) .....	46
Maximum Junction Temperature (Hermetic Package or Die) . . .	175 $^{\circ}C$
Maximum Junction Temperature (Plastic Package) .....	150 $^{\circ}C$
Maximum Storage Temperature Range .....	-65 $^{\circ}C$ to 150 $^{\circ}C$
Maximum Lead Temperature (Soldering 10s) .....	300 $^{\circ}C$

### Operating Conditions

Temperature Range, $T_A$ .....	-55 $^{\circ}C$ to 125 $^{\circ}C$
Supply Voltage Range, $V_{CC}$ .....	2V to 6V
DC Input or Output Voltage, $V_I, V_O$ .....	0V to $V_{CC}$
Input Rise and Fall Time	
2V .....	1000ns (Max)
4.5V .....	500ns (Max)
6V .....	400ns (Max)

*CAUTION: Stresses above those listed in "Absolute Maximum Ratings" may cause permanent damage to the device. This is a stress only rating and operation of the device at these or any other conditions above those indicated in the operational sections of this specification is not implied.*

#### NOTES:

3. The package thermal impedance is calculated in accordance with JESD 51-3.
4. The package thermal impedance is calculated in accordance with JESD 51-7.

### DC Electrical Specifications

PARAMETER	SYMBOL	TEST CONDITIONS		$V_{CC}$ (V)	25 $^{\circ}C$			-40 $^{\circ}C$ TO 85 $^{\circ}C$		-55 $^{\circ}C$ TO 125 $^{\circ}C$		UNITS	
		$V_I$ (V)	$I_O$ (mA)		MIN	TYP	MAX	MIN	MAX	MIN	MAX		
High Level Input Voltage	$V_{IH}$	-	-	2	1.5	-	-	1.5	-	1.5	-	V	
				4.5	3.15	-	-	3.15	-	3.15	-	V	
				6	4.2	-	-	4.2	-	4.2	-	V	
Low Level Input Voltage	$V_{IL}$	-	-	2	-	-	0.5	-	0.5	-	0.5	V	
				4.5	-	-	1.35	-	1.35	-	1.35	V	
				6	-	-	1.8	-	1.8	-	1.8	V	
High Level Output Voltage CMOS Loads	$V_{OH}$	$V_{IH}$ or $V_{IL}$	-0.02	-0.02	2	1.9	-	-	1.9	-	1.9	-	V
					4.5	4.4	-	-	4.4	-	4.4	-	V
					6	5.9	-	-	5.9	-	5.9	-	V
High Level Output Voltage TTL Loads	$V_{OH}$	$V_{IH}$ or $V_{IL}$	-	-	-	-	-	-	-	-	-	V	
					4	3.98	-	-	3.84	-	3.7	-	V
					5.2	5.48	-	-	5.34	-	5.2	-	V
Low Level Output Voltage CMOS Loads	$V_{OL}$	$V_{IH}$ or $V_{IL}$	0.02	0.02	2	-	-	0.1	-	0.1	-	0.1	V
					4.5	-	-	0.1	-	0.1	-	0.1	V
					6	-	-	0.1	-	0.1	-	0.1	V
Low Level Output Voltage TTL Loads	$V_{OL}$	$V_{IH}$ or $V_{IL}$	-	-	-	-	-	-	-	-	-	V	
					4	0.26	-	-	0.33	-	0.4	-	V
					5.2	0.26	-	-	0.33	-	0.4	-	V
Input Leakage Current	$I_I$	$V_{CC}$ or GND	-	6	-	-	$\pm 0.1$	-	$\pm 1$	-	$\pm 1$	$\mu A$	
Quiescent Device Current	$I_{CC}$	$V_{CC}$ or GND	0	6	-	-	8	-	80	-	160	$\mu A$	

## CD54HC4059, CD74HC4059

### Prerequisite for Switching Specifications

PARAMETER	SYMBOL	V <sub>CC</sub> (V)	25°C			-40°C TO 85°C			-55°C TO 125°C			UNITS
			MIN	TYP	MAX	MIN	TYP	MAX	MIN	TYP	MAX	
Pulse Width CP	t <sub>W</sub>	2	90	-	-	115	-	-	135	-	-	ns
		4.5	18	-	-	23	-	-	27	-	-	ns
		6	15	-	-	20	-	-	23	-	-	ns
Setup Time K <sub>b</sub> , K <sub>c</sub> to CP	t <sub>SU</sub>	2	75	-	-	95	-	-	110	-	-	ns
		4.5	15	-	-	19	-	-	22	-	-	ns
		6	13	-	-	16	-	-	19	-	-	ns
CP Frequency	f <sub>MAX</sub>	2	5	-	-	4	-	-	4	-	-	MHz
		4.5	27	-	-	22	-	-	18	-	-	MHz
		6	32	-	-	26	-	-	21	-	-	MHz

### Switching Specifications Input t<sub>r</sub>, t<sub>f</sub> = 6ns

PARAMETER	SYMBOL	TEST CONDITIONS	V <sub>CC</sub> (V)	25°C			-40°C TO 85°C		-55°C TO 125°C		UNITS
				MIN	TYP	MAX	MIN	MAX	MIN	MAX	
Propagation Delay, CP to Q	t <sub>PLH</sub> , t <sub>PHL</sub>	C <sub>L</sub> = 50pF	2	-	-	200	-	250	-	300	ns
			4.5	-	-	40	-	50	-	60	ns
			6	-	-	34	-	43	-	51	ns
Propagation Delay, LE to Q	t <sub>PLH</sub> , t <sub>PHL</sub>	C <sub>L</sub> = 15pF	5	-	17	-	-	-	-	-	ns
			2	-	-	175	-	220	-	265	ns
		C <sub>L</sub> = 50pF	4.5	-	-	35	-	44	-	53	ns
			6	-	-	30	-	37	-	45	ns
Output Transition Time	t <sub>THL</sub> , t <sub>TLH</sub>	C <sub>L</sub> = 50pF	2	-	-	75	-	95	-	110	ns
			4.5	-	-	15	-	19	-	22	ns
			6	-	-	13	-	16	-	19	ns
CP Frequency	f <sub>MAX</sub>	C <sub>L</sub> = 15pF	5	-	54	-	-	-	-	MHz	
Input Capacitance	C <sub>I</sub>	-	-	-	-	10	-	10	-	10	pF
Power Dissipation Capacitance (Notes 5, 6)	C <sub>PD</sub>	-	5	-	36	-	-	-	-	-	pF

#### NOTES:

5. C<sub>PD</sub> is used to determine the dynamic power consumption, per package.
6.  $P_D = C_{PD} V_{CC}^2 f_i + \sum C_L V_{CC}^2 f_o$  where  $f_i$  = input frequency,  $f_o$  = output frequency,  $C_L$  = output load capacitance,  $V_{CC}$  = supply voltage.

## CD54HC4059, CD74HC4059

### Test Circuits and Waveforms

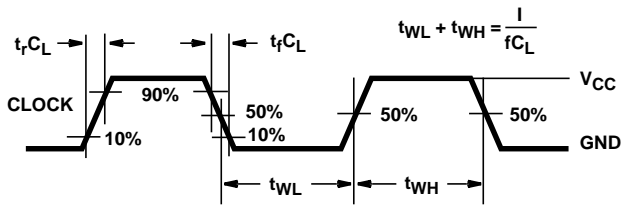

NOTE: Outputs should be switching from 10%  $V_{CC}$  to 90%  $V_{CC}$  in accordance with device truth table. For  $f_{MAX}$ , input duty cycle = 50%.

**FIGURE 2. HC CLOCK PULSE RISE AND FALL TIMES AND PULSE WIDTH**

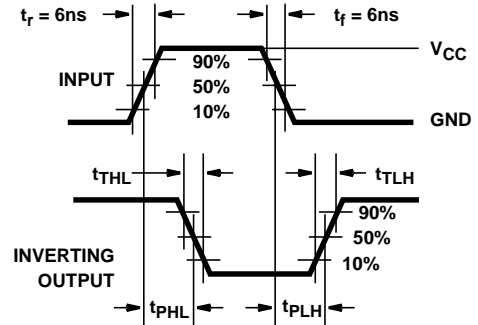

**FIGURE 3. HC TRANSITION TIMES AND PROPAGATION DELAY TIMES, COMBINATION LOGIC**

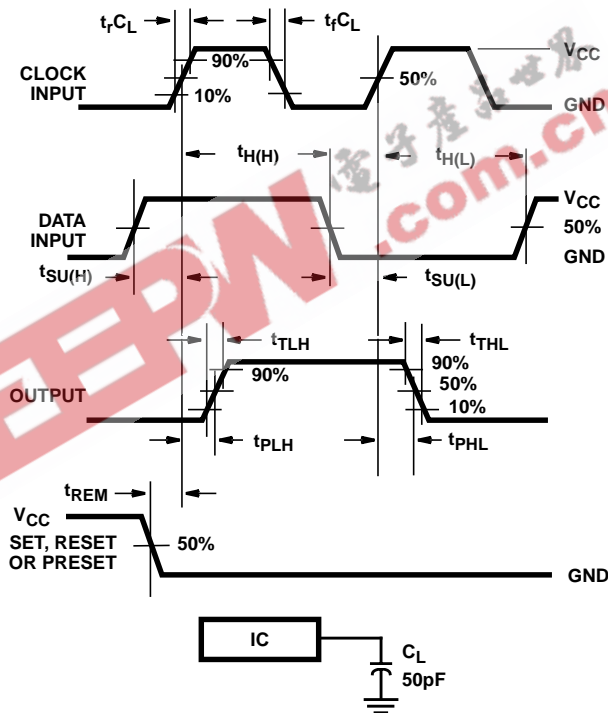

**FIGURE 4. HC SETUP TIMES, HOLD TIMES, REMOVAL TIME, AND PROPAGATION DELAY TIMES FOR EDGE TRIGGERED SEQUENTIAL LOGIC CIRCUITS**

**PACKAGING INFORMATION**

Orderable Device	Status <sup>(1)</sup>	Package Type	Package Drawing	Pins	Package Qty	Eco Plan <sup>(2)</sup>	Lead/Ball Finish	MSL Peak Temp <sup>(3)</sup>
5962-8944501JA	ACTIVE	CDIP	J	24	1	TBD	A42 SNPB	N / A for Pkg Type
CD54HC4059F3A	ACTIVE	CDIP	J	24	1	TBD	A42 SNPB	N / A for Pkg Type
CD74HC4059E	ACTIVE	PDIP	N	24	15	Pb-Free (RoHS)	CU NIPDAU	N / A for Pkg Type
CD74HC4059EE4	ACTIVE	PDIP	N	24	15	Pb-Free (RoHS)	CU NIPDAU	N / A for Pkg Type
CD74HC4059M96	ACTIVE	SOIC	DW	24	2000	Green (RoHS & no Sb/Br)	CU NIPDAU	Level-1-260C-UNLIM
CD74HC4059M96E4	ACTIVE	SOIC	DW	24	2000	Green (RoHS & no Sb/Br)	CU NIPDAU	Level-1-260C-UNLIM
CD74HC4059M96G4	ACTIVE	SOIC	DW	24	2000	Green (RoHS & no Sb/Br)	CU NIPDAU	Level-1-260C-UNLIM

<sup>(1)</sup> The marketing status values are defined as follows:

**ACTIVE:** Product device recommended for new designs.

**LIFEBUY:** TI has announced that the device will be discontinued, and a lifetime-buy period is in effect.

**NRND:** Not recommended for new designs. Device is in production to support existing customers, but TI does not recommend using this part in a new design.

**PREVIEW:** Device has been announced but is not in production. Samples may or may not be available.

**OBSOLETE:** TI has discontinued the production of the device.

<sup>(2)</sup> Eco Plan - The planned eco-friendly classification: Pb-Free (RoHS), Pb-Free (RoHS Exempt), or Green (RoHS & no Sb/Br) - please check <http://www.ti.com/productcontent> for the latest availability information and additional product content details.

**TBD:** The Pb-Free/Green conversion plan has not been defined.

**Pb-Free (RoHS):** TI's terms "Lead-Free" or "Pb-Free" mean semiconductor products that are compatible with the current RoHS requirements for all 6 substances, including the requirement that lead not exceed 0.1% by weight in homogeneous materials. Where designed to be soldered at high temperatures, TI Pb-Free products are suitable for use in specified lead-free processes.

**Pb-Free (RoHS Exempt):** This component has a RoHS exemption for either 1) lead-based flip-chip solder bumps used between the die and package, or 2) lead-based die adhesive used between the die and leadframe. The component is otherwise considered Pb-Free (RoHS compatible) as defined above.

**Green (RoHS & no Sb/Br):** TI defines "Green" to mean Pb-Free (RoHS compatible), and free of Bromine (Br) and Antimony (Sb) based flame retardants (Br or Sb do not exceed 0.1% by weight in homogeneous material)

<sup>(3)</sup> MSL, Peak Temp. -- The Moisture Sensitivity Level rating according to the JEDEC industry standard classifications, and peak solder temperature.

**Important Information and Disclaimer:**The information provided on this page represents TI's knowledge and belief as of the date that it is provided. TI bases its knowledge and belief on information provided by third parties, and makes no representation or warranty as to the accuracy of such information. Efforts are underway to better integrate information from third parties. TI has taken and continues to take reasonable steps to provide representative and accurate information but may not have conducted destructive testing or chemical analysis on incoming materials and chemicals. TI and TI suppliers consider certain information to be proprietary, and thus CAS numbers and other limited information may not be available for release.

In no event shall TI's liability arising out of such information exceed the total purchase price of the TI part(s) at issue in this document sold by TI to Customer on an annual basis.

**TAPE AND REEL BOX INFORMATION**

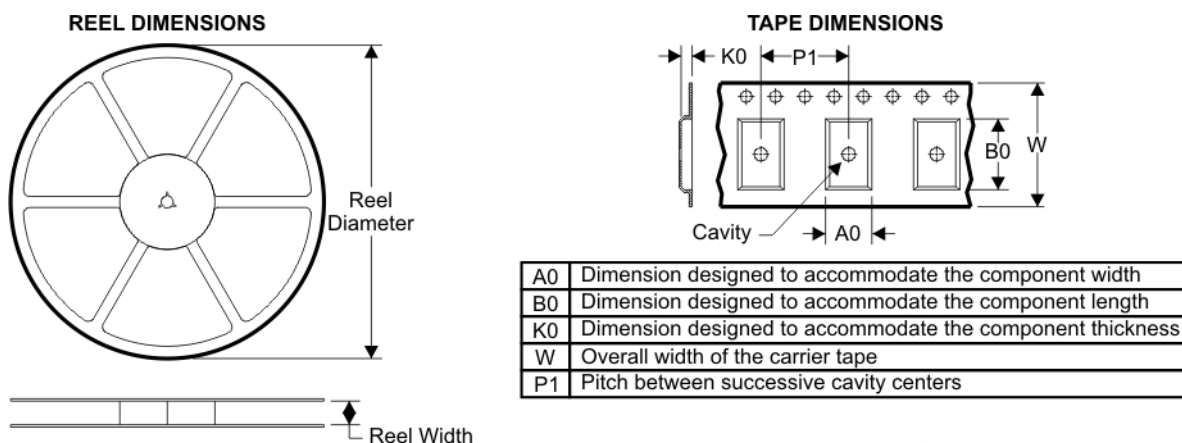

**QUADRANT ASSIGNMENTS FOR PIN 1 ORIENTATION IN TAPE**

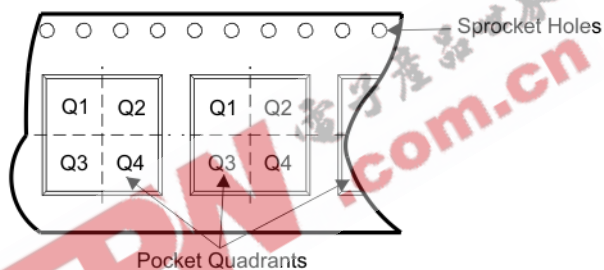

Device	Package	Pins	Site	Reel Diameter (mm)	Reel Width (mm)	A0 (mm)	B0 (mm)	K0 (mm)	P1 (mm)	W (mm)	Pin1 Quadrant
CD74HC4059M96	DW	24	SITE 60	330	24	10.75	15.7	2.7	12	24	Q1



**TAPE AND REEL BOX DIMENSIONS**

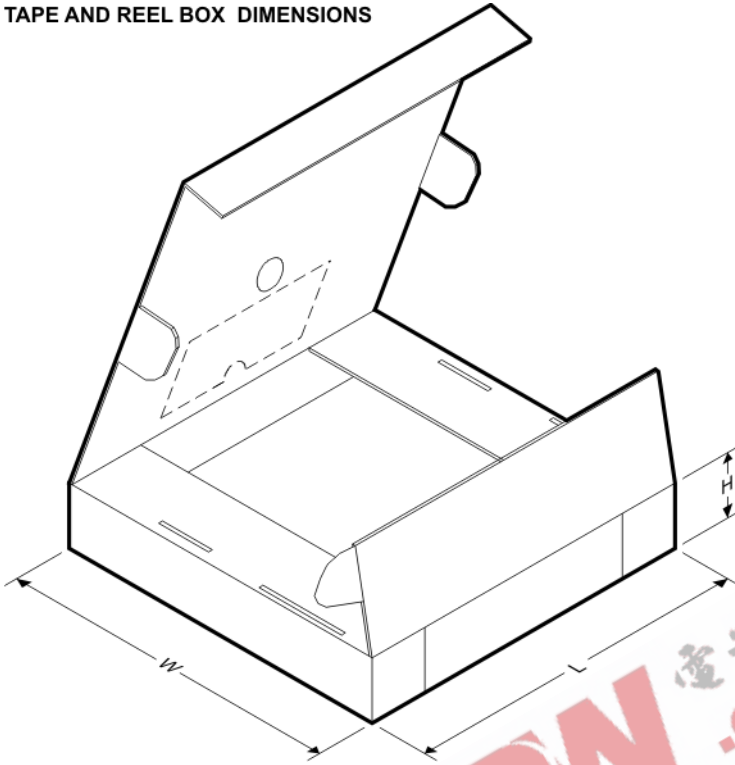

Device	Package	Pins	Site	Length (mm)	Width (mm)	Height (mm)
CD74HC4059M96	DW	24	SITE 60	346.0	346.0	41.0

# MECHANICAL DATA

MCDI004A – JANUARY 1995 – REVISED NOVEMBER 1997

## J (R-GDIP-T\*\*)

## CERAMIC DUAL-IN-LINE PACKAGE

24 PINS SHOWN

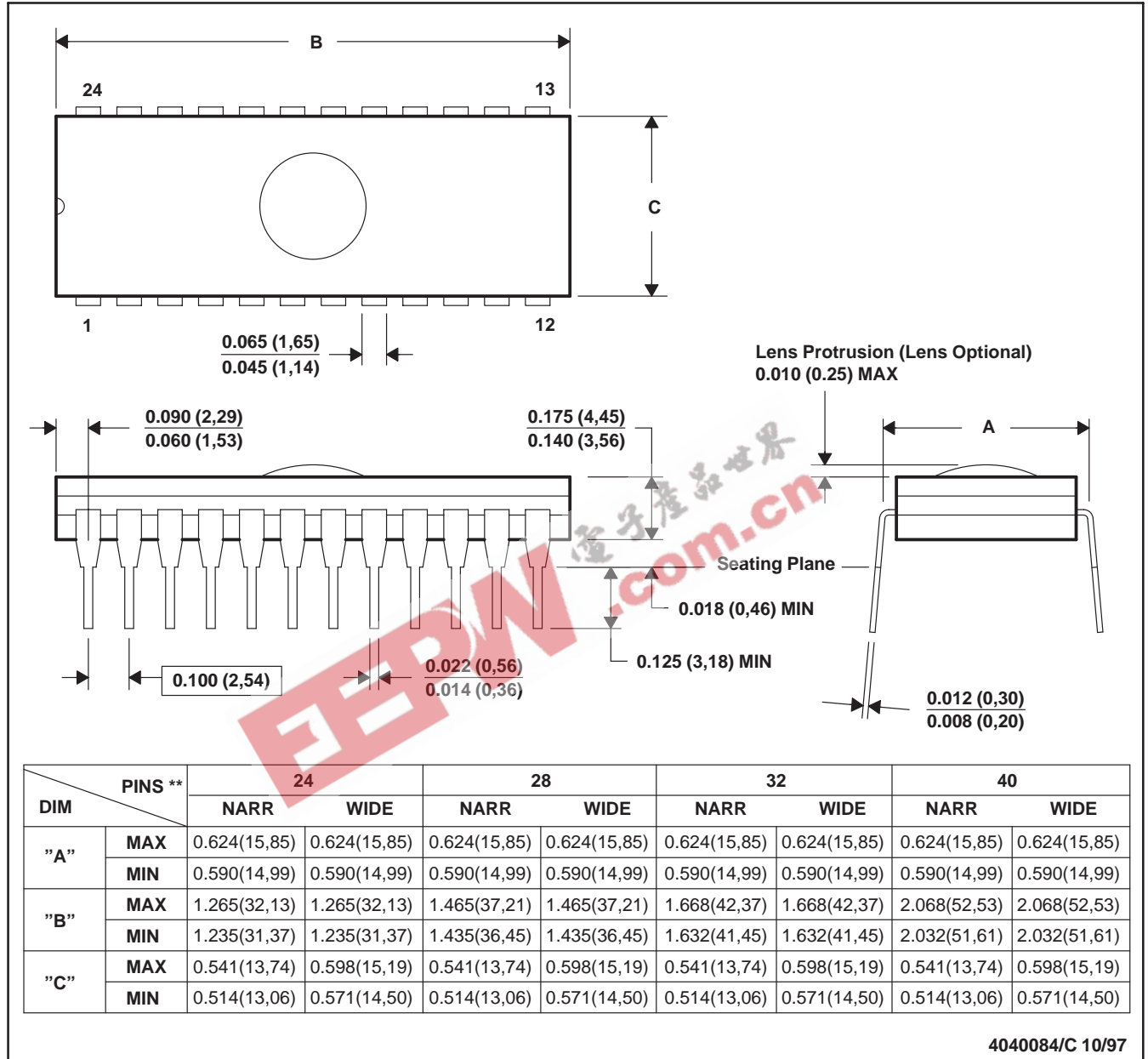

- NOTES: A. All linear dimensions are in inches (millimeters).  
 B. This drawing is subject to change without notice.  
 C. Window (lens) added to this group of packages (24-, 28-, 32-, 40-pin).  
 D. This package can be hermetically sealed with a ceramic lid using glass frit.  
 E. Index point is provided on cap for terminal identification.

# MECHANICAL DATA

MPDI006B – SEPTEMBER 2001 – REVISED APRIL 2002

N (R-PDIP-T24)

PLASTIC DUAL-IN-LINE

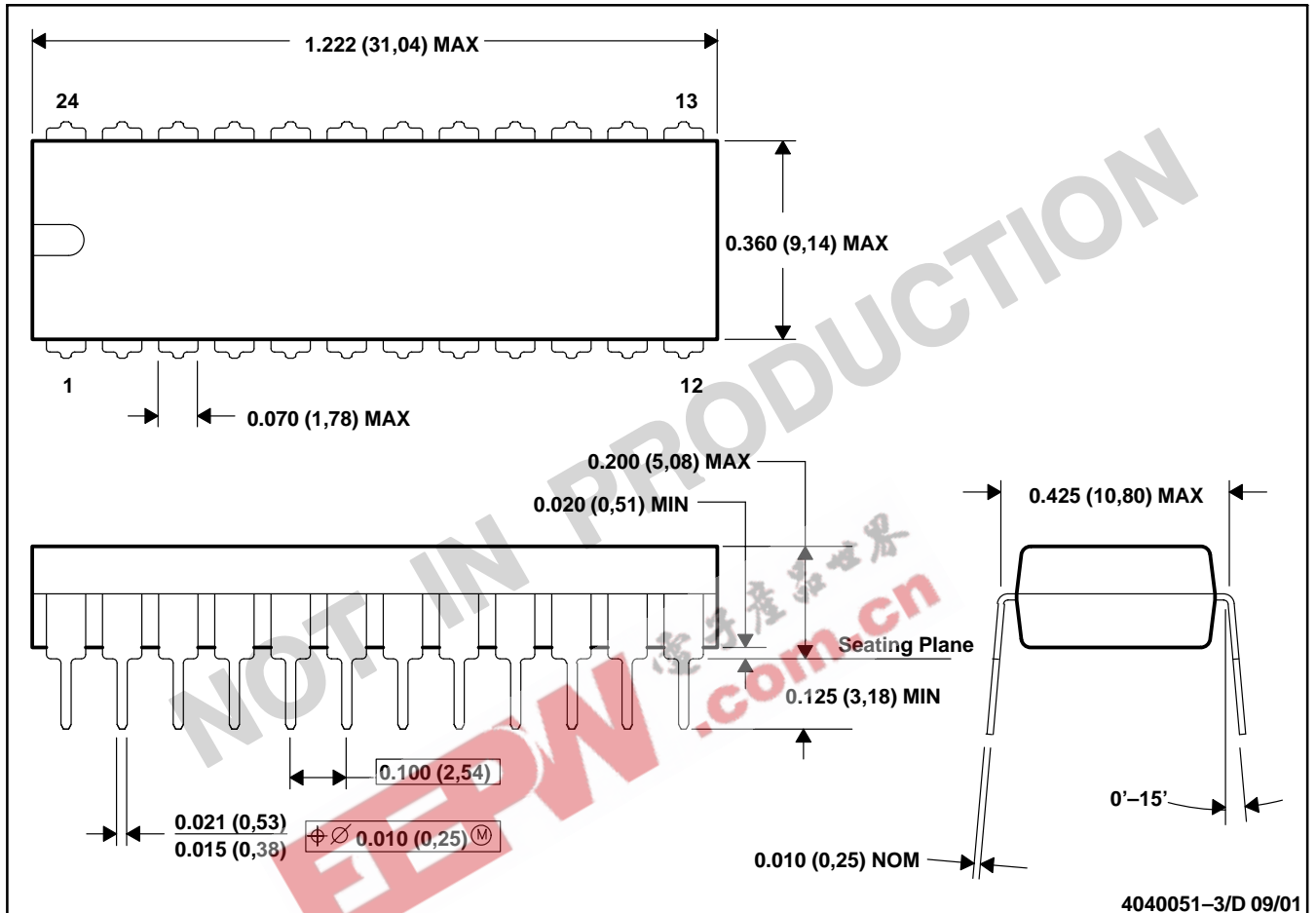

- NOTES:
- A. All linear dimensions are in inches (millimeters).
  - B. This drawing is subject to change without notice.
  - C. Falls within JEDEC MS-010

# MECHANICAL DATA

MPDI008 – OCTOBER 1994

**N (R-PDIP-T\*\*)**

**PLASTIC DUAL-IN-LINE PACKAGE**

24 PIN SHOWN

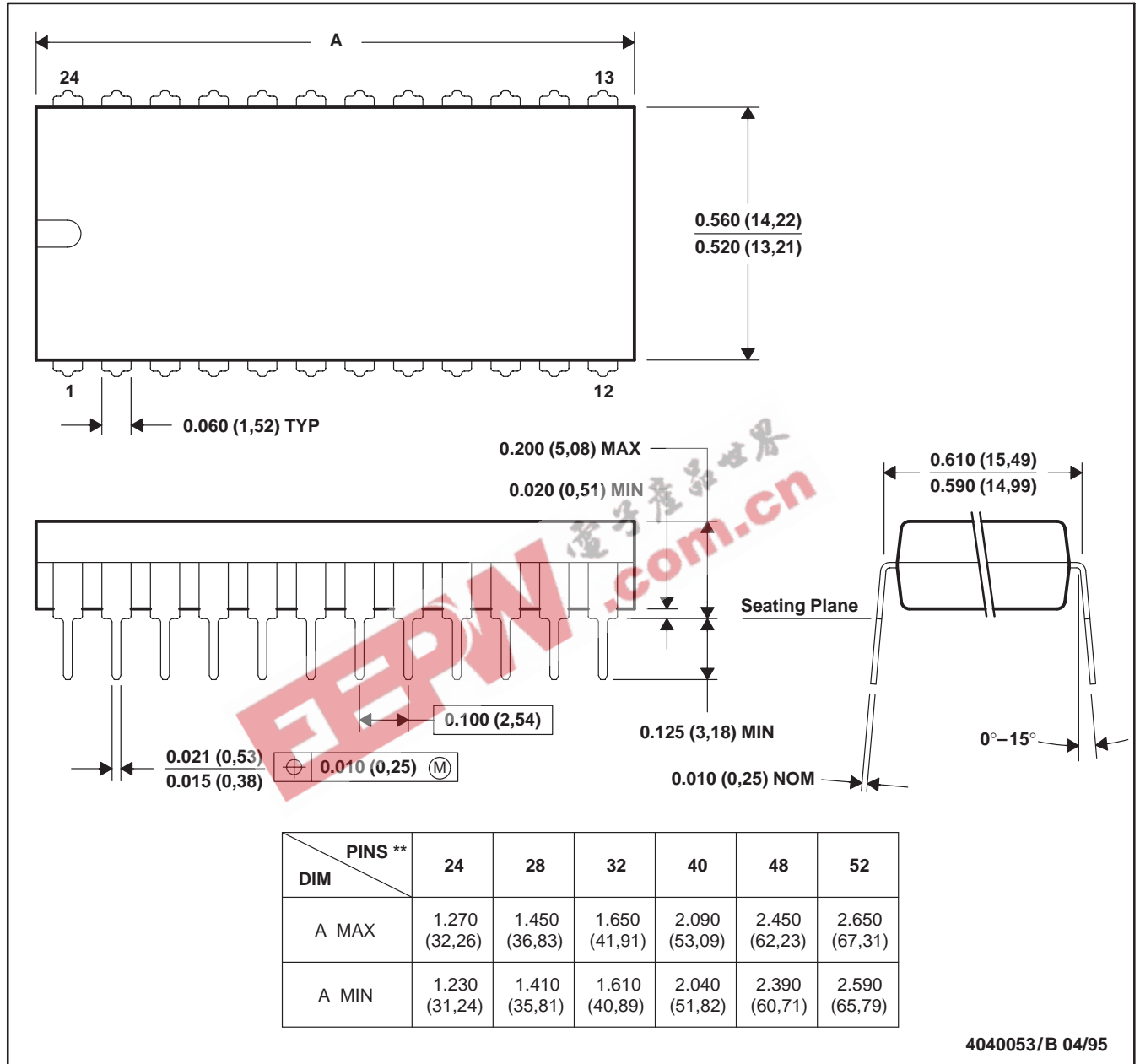

- NOTES: A. All linear dimensions are in inches (millimeters).  
 B. This drawing is subject to change without notice.  
 C. Falls within JEDEC MS-011  
 D. Falls within JEDEC MS-015 (32 pin only)

# MECHANICAL DATA

DW (R-PDSO-G24)

PLASTIC SMALL-OUTLINE PACKAGE

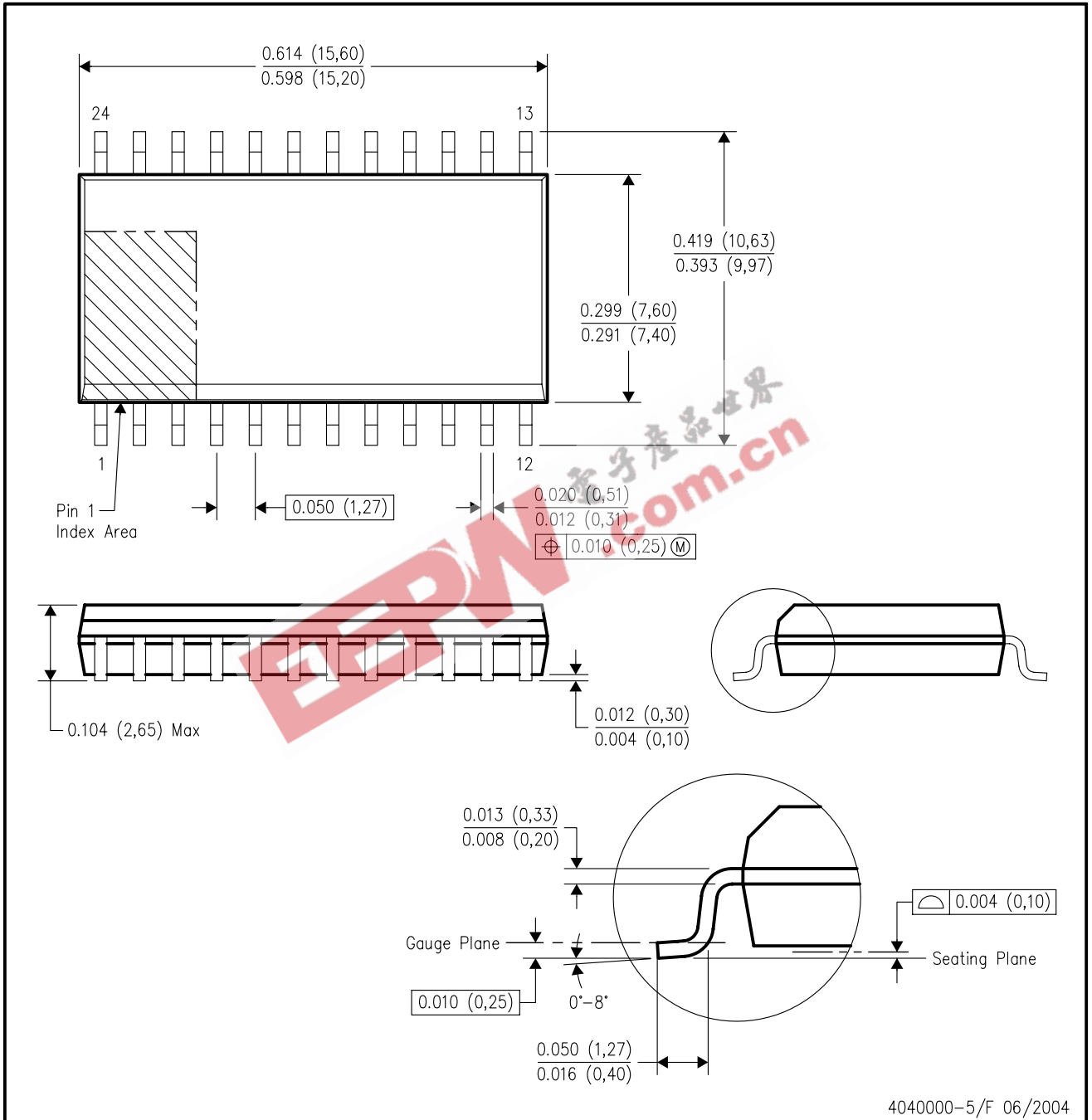

- NOTES:
- All linear dimensions are in inches (millimeters).
  - This drawing is subject to change without notice.
  - Body dimensions do not include mold flash or protrusion not to exceed 0.006 (0,15).
  - Falls within JEDEC MS-013 variation AD.

## IMPORTANT NOTICE

Texas Instruments Incorporated and its subsidiaries (TI) reserve the right to make corrections, modifications, enhancements, improvements, and other changes to its products and services at any time and to discontinue any product or service without notice. Customers should obtain the latest relevant information before placing orders and should verify that such information is current and complete. All products are sold subject to TI's terms and conditions of sale supplied at the time of order acknowledgment.

TI warrants performance of its hardware products to the specifications applicable at the time of sale in accordance with TI's standard warranty. Testing and other quality control techniques are used to the extent TI deems necessary to support this warranty. Except where mandated by government requirements, testing of all parameters of each product is not necessarily performed.

TI assumes no liability for applications assistance or customer product design. Customers are responsible for their products and applications using TI components. To minimize the risks associated with customer products and applications, customers should provide adequate design and operating safeguards.

TI does not warrant or represent that any license, either express or implied, is granted under any TI patent right, copyright, mask work right, or other TI intellectual property right relating to any combination, machine, or process in which TI products or services are used. Information published by TI regarding third-party products or services does not constitute a license from TI to use such products or services or a warranty or endorsement thereof. Use of such information may require a license from a third party under the patents or other intellectual property of the third party, or a license from TI under the patents or other intellectual property of TI.

Reproduction of TI information in TI data books or data sheets is permissible only if reproduction is without alteration and is accompanied by all associated warranties, conditions, limitations, and notices. Reproduction of this information with alteration is an unfair and deceptive business practice. TI is not responsible or liable for such altered documentation. Information of third parties may be subject to additional restrictions.

Resale of TI products or services with statements different from or beyond the parameters stated by TI for that product or service voids all express and any implied warranties for the associated TI product or service and is an unfair and deceptive business practice. TI is not responsible or liable for any such statements.

TI products are not authorized for use in safety-critical applications (such as life support) where a failure of the TI product would reasonably be expected to cause severe personal injury or death, unless officers of the parties have executed an agreement specifically governing such use. Buyers represent that they have all necessary expertise in the safety and regulatory ramifications of their applications, and acknowledge and agree that they are solely responsible for all legal, regulatory and safety-related requirements concerning their products and any use of TI products in such safety-critical applications, notwithstanding any applications-related information or support that may be provided by TI. Further, Buyers must fully indemnify TI and its representatives against any damages arising out of the use of TI products in such safety-critical applications.

TI products are neither designed nor intended for use in military/aerospace applications or environments unless the TI products are specifically designated by TI as military-grade or "enhanced plastic." Only products designated by TI as military-grade meet military specifications. Buyers acknowledge and agree that any such use of TI products which TI has not designated as military-grade is solely at the Buyer's risk, and that they are solely responsible for compliance with all legal and regulatory requirements in connection with such use.

TI products are neither designed nor intended for use in automotive applications or environments unless the specific TI products are designated by TI as compliant with ISO/TS 16949 requirements. Buyers acknowledge and agree that, if they use any non-designated products in automotive applications, TI will not be responsible for any failure to meet such requirements.

Following are URLs where you can obtain information on other Texas Instruments products and application solutions:

<b>Products</b>		<b>Applications</b>	
Amplifiers	<a href="http://amplifier.ti.com">amplifier.ti.com</a>	Audio	<a href="http://www.ti.com/audio">www.ti.com/audio</a>
Data Converters	<a href="http://dataconverter.ti.com">dataconverter.ti.com</a>	Automotive	<a href="http://www.ti.com/automotive">www.ti.com/automotive</a>
DSP	<a href="http://dsp.ti.com">dsp.ti.com</a>	Broadband	<a href="http://www.ti.com/broadband">www.ti.com/broadband</a>
Interface	<a href="http://interface.ti.com">interface.ti.com</a>	Digital Control	<a href="http://www.ti.com/digitalcontrol">www.ti.com/digitalcontrol</a>
Logic	<a href="http://logic.ti.com">logic.ti.com</a>	Military	<a href="http://www.ti.com/military">www.ti.com/military</a>
Power Mgmt	<a href="http://power.ti.com">power.ti.com</a>	Optical Networking	<a href="http://www.ti.com/opticalnetwork">www.ti.com/opticalnetwork</a>
Microcontrollers	<a href="http://microcontroller.ti.com">microcontroller.ti.com</a>	Security	<a href="http://www.ti.com/security">www.ti.com/security</a>
RFID	<a href="http://www.ti-rfid.com">www.ti-rfid.com</a>	Telephony	<a href="http://www.ti.com/telephony">www.ti.com/telephony</a>
Low Power Wireless	<a href="http://www.ti.com/lpw">www.ti.com/lpw</a>	Video & Imaging	<a href="http://www.ti.com/video">www.ti.com/video</a>
		Wireless	<a href="http://www.ti.com/wireless">www.ti.com/wireless</a>

Mailing Address: Texas Instruments, Post Office Box 655303, Dallas, Texas 75265  
Copyright © 2007, Texas Instruments Incorporated