

# 仕様書

形名

CD54

## 1. 外形

### 1-1. 寸法図(mm)

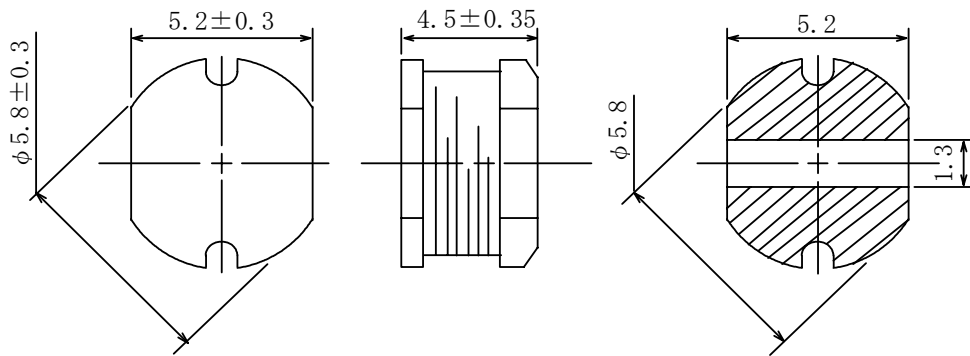

\* 公差のない寸法は、参考値とする。

### 1-2. 捺印表示例

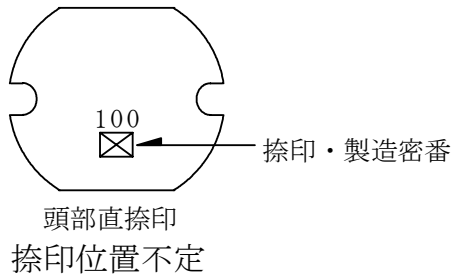

### 1-3. 推奨ランド寸法(mm)

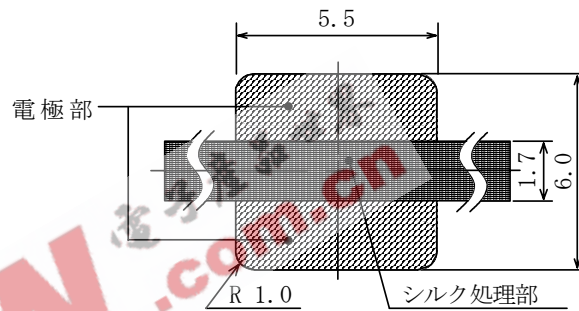

電極(端子)間の隙間はシルク処理をして御使用下さい。

## 2. コイル仕様

### 2-1. 端子接続図(裏面図)

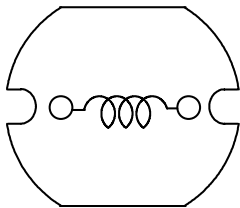

RoHS

compliance

Cd:Max. 0.01wt%

others:Max. 0.1wt%



# 仕様書

形名  
CD54

## 2-2. 電気的特性

NO.	品名	表示	インダクタンス [以内] ※1	D. C. R. ( $\Omega$ ) [以下] (at 20°C)	定格電流 (A) ※2	S. R. F. (MHz) [参考値]	スミダ コード
01	CD54NP-100MC	100	10 $\mu$ H $\pm$ 20%	0.10	1.44	30.6	-0226
02	CD54NP-100MB						-0227
03	CD54NP-120MC	120	12 $\mu$ H $\pm$ 20%	0.12	1.40	27.7	-0228
04	CD54NP-120MB						-0231
05	CD54NP-150MC	150	15 $\mu$ H $\pm$ 20%	0.14	1.30	25.9	-0232
06	CD54NP-150MB						-0233
07	CD54NP-180MC	180	18 $\mu$ H $\pm$ 20%	0.15	1.23	23.3	-0234
08	CD54NP-180MB						-0235
09	CD54NP-220MC	220	22 $\mu$ H $\pm$ 20%	0.18	1.11	19.5	-0236
10	CD54NP-220MB						-0237
11	CD54NP-270MC	270	27 $\mu$ H $\pm$ 20%	0.20	0.97	17.5	-0238
12	CD54NP-270MB						-0239
13	CD54NP-330LC	330	33 $\mu$ H $\pm$ 15%	0.23	0.88	16.3	-0240
14	CD54NP-330LB						-0242
15	CD54NP-390LC	390	39 $\mu$ H $\pm$ 15%	0.32	0.80	15.8	-0243
16	CD54NP-390LB						-0244
17	CD54NP-470LC	470	47 $\mu$ H $\pm$ 15%	0.37	0.72	13.6	-0245
18	CD54NP-470LB						-0246
19	CD54NP-560KC	560	56 $\mu$ H $\pm$ 10%	0.42	0.68	12.1	-0247
20	CD54NP-560KB						-0248
21	CD54NP-680KC	680	68 $\mu$ H $\pm$ 10%	0.46	0.61	11.7	-0249
22	CD54NP-680KB						-0250
23	CD54NP-820KC	820	82 $\mu$ H $\pm$ 10%	0.60	0.58	10.2	-0251
24	CD54NP-820KB						-0253
25	CD54NP-101KC	101	100 $\mu$ H $\pm$ 10%	0.70	0.52	9.24	-0254
26	CD54NP-101KB						-0255
27	CD54NP-121KC	121	120 $\mu$ H $\pm$ 10%	0.93	0.48	8.61	-0256
28	CD54NP-121KB						-0257
29	CD54NP-151KC	151	150 $\mu$ H $\pm$ 10%	1.10	0.40	8.28	-0258
30	CD54NP-151KB						-0259
31	CD54NP-181KC	181	180 $\mu$ H $\pm$ 10%	1.38	0.38	6.42	-0260
32	CD54NP-181KB						-0261
33	CD54NP-221KC	221	220 $\mu$ H $\pm$ 10%	1.57	0.35	5.73	-0262
34	CD54NP-221KB						-0264

\* 品名表示の区分

(1) リール梱包の場合: CD54NP-XXXXC

(2) 箱梱包の場合: CD54NP-XXXXB

※1: 測定周波数 L 10  $\mu$  H  $\sim$  82  $\mu$  H ; at 2.52 MHz

100  $\mu$  H  $\sim$  220  $\mu$  H ; at 1 kHz

※2: 定格電流は直流重畳特性に於て、インダクタンスが初期値より-10%となる電流もしくは直流電流を流した時のコイルの発熱が $\Delta t=40^{\circ}\text{C}$ となる電流値の少ない方の値。(Ta=20°Cを基準とする。)

3. 保存温度範囲

-40°C $\sim$ +100°C

使用温度範囲

-40°C $\sim$ +100°C (コイルの発熱を含む。)

# SPECIFICATION

TYPE CD54
--------------

## 1. APPEARANCE

### 1-1. DIMENSIONS (mm)

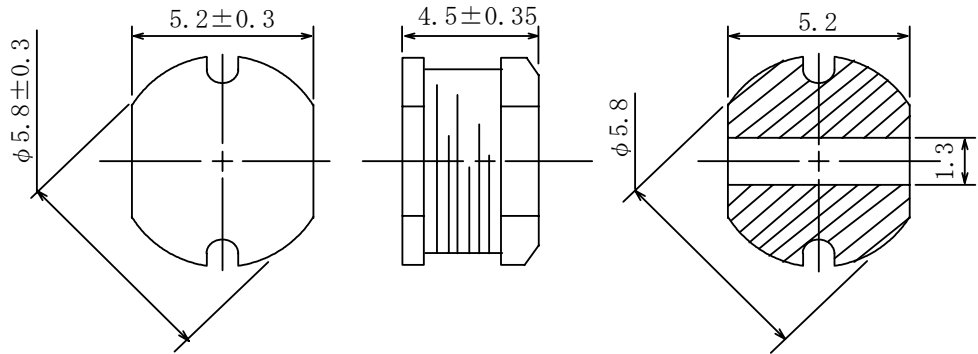

\* DIMENSION DOES NOT INCLUDE SOLDER USED ON COIL.

### 1-2. STAMP (E. G.)

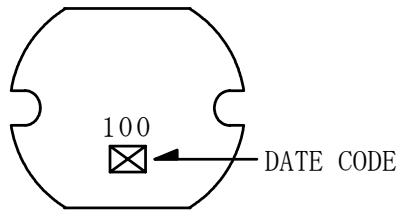

DIRECTLY STAMP  
UNFIXED POSITION

### 1-3. RECOMMENDED LAND PATTERNS DIMENSION (mm)

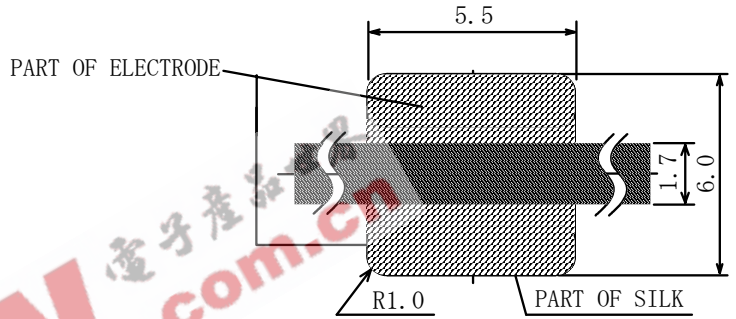

PLEASE COAT WITH SILK SCREEN BETWEEN THE TWO ELECTRODES.

## 2. COIL SPECIFICATION

### 2-1. CONNECTION (BOTTOM VIEW)

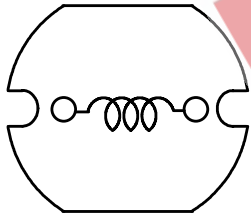

<p>RoHS compliance Cd:Max. 0.01wt% others:Max. 0.1wt%</p>
---



# SPECIFICATION

TYPE CD54
--------------

## 2-2. ELECTRICAL CHARACTERISTICS

NO.	PART NO.	STAMP	INDUCTANCE [WITHIN] ※1	D. C. R. ( $\Omega$ ) [MAX.] (at 20°C)	RATED CURRENT (A) ※2	S. R. F. (MHz) [TYP.]	SUMIDA CODE
01	CD54NP-100MC	100	10 $\mu$ H $\pm$ 20%	0.10	1.44	30.6	-0226
02	CD54NP-100MB						-0227
03	CD54NP-120MC	120	12 $\mu$ H $\pm$ 20%	0.12	1.40	27.7	-0228
04	CD54NP-120MB						-0231
05	CD54NP-150MC	150	15 $\mu$ H $\pm$ 20%	0.14	1.30	25.9	-0232
06	CD54NP-150MB						-0233
07	CD54NP-180MC	180	18 $\mu$ H $\pm$ 20%	0.15	1.23	23.3	-0234
08	CD54NP-180MB						-0235
09	CD54NP-220MC	220	22 $\mu$ H $\pm$ 20%	0.18	1.11	19.5	-0236
10	CD54NP-220MB						-0237
11	CD54NP-270MC	270	27 $\mu$ H $\pm$ 20%	0.20	0.97	17.5	-0238
12	CD54NP-270MB						-0239
13	CD54NP-330LC	330	33 $\mu$ H $\pm$ 15%	0.23	0.88	16.3	-0240
14	CD54NP-330LB						-0242
15	CD54NP-390LC	390	39 $\mu$ H $\pm$ 15%	0.32	0.80	15.8	-0243
16	CD54NP-390LB						-0244
17	CD54NP-470LC	470	47 $\mu$ H $\pm$ 15%	0.37	0.72	13.6	-0245
18	CD54NP-470LB						-0246
19	CD54NP-560KC	560	56 $\mu$ H $\pm$ 10%	0.42	0.68	12.1	-0247
20	CD54NP-560KB						-0248
21	CD54NP-680KC	680	68 $\mu$ H $\pm$ 10%	0.46	0.61	11.7	-0249
22	CD54NP-680KB						-0250
23	CD54NP-820KC	820	82 $\mu$ H $\pm$ 10%	0.60	0.58	10.2	-0251
24	CD54NP-820KB						-0253
25	CD54NP-101KC	101	100 $\mu$ H $\pm$ 10%	0.70	0.52	9.24	-0254
26	CD54NP-101KB						-0255
27	CD54NP-121KC	121	120 $\mu$ H $\pm$ 10%	0.93	0.48	8.61	-0256
28	CD54NP-121KB						-0257
29	CD54NP-151KC	151	150 $\mu$ H $\pm$ 10%	1.10	0.40	8.28	-0258
30	CD54NP-151KB						-0259
31	CD54NP-181KC	181	180 $\mu$ H $\pm$ 10%	1.38	0.38	6.42	-0260
32	CD54NP-181KB						-0261
33	CD54NP-221KC	221	220 $\mu$ H $\pm$ 10%	1.57	0.35	5.73	-0262
34	CD54NP-221KB						-0264

\* PART NO. DESCRIPTION

(1) IN CASE OF REEL PACKING: CD54NP-XXXXC

(2) IN CASE OF BOX PACKING: CD54NP-XXXXB

※1 MEASURING FREQUENCY INDUCTANCE : 10  $\mu$  H  $\sim$  82  $\mu$  H at 2.52 MHz  
100  $\mu$  H  $\sim$  220  $\mu$  H at 1 kHz

※2 THE RATED CURRENT INDICATES THE LOWER VALUE OF CURRENT WHEN THE INDUCTANCE IS 10% LOWER THAN ITS INITIAL VALUE AT D.C. SUPERPOSITION OR THE TEMPERATURE OF COIL RISES 40°C WITH D.C. CURRENT PASSING. (Ta=20°C)

3. STORAGE TEMPERATURE RANGE : -40°C  $\sim$  +100°C

OPERATING TEMPERATURE RANGE: -40°C  $\sim$  +100°C (INCLUDING COIL'S SELF TEMPERATURE RISE)