

CD4013BC Dual D-Type Flip-Flop

General Description

The CD4013B dual D-type flip-flop is a monolithic complementary MOS (CMOS) integrated circuit constructed with N- and P-channel enhancement mode transistors. Each flip-flop has independent data, set, reset, and clock inputs and "Q" and "Q̄" outputs. These devices can be used for shift register applications, and by connecting "Q̄" output to the data input, for counter and toggle applications. The logic level present at the "D" input is transferred to the Q output during the positive-going transition of the clock pulse. Setting or resetting is independent of the clock and is accomplished by a high level on the set or reset line respectively.

Features

- Wide supply voltage range: 3.0V to 15V
- High noise immunity: $0.45 V_{DD}$ (typ.)
- Low power TTL: fan out of 2 driving 74L compatibility: or 1 driving 74LS

Applications

- Automotive
- Data terminals
- Instrumentation
- Medical electronics
- Alarm system
- Industrial electronics
- Remote metering
- Computers

Ordering Code:

Order Number	Package Number	Package Description
CD4013BCM	M14A	14-Lead Small Outline Integrated Circuit (SOIC), JEDEC MS-120, 0.150" Narrow
CD4013BCSJ	M14D	14-Lead Small Outline Package (SOP), EIAJ TYPE II, 5.3mm Wide
CD4013BCN	N14A	14-Lead Dual-In-Line Package (PDIP), JEDEC MS-001, 0.300" Wide

Devices also available in Tape and Reel. Specify by appending the suffix letter "X" to the ordering code.

Connection Diagram

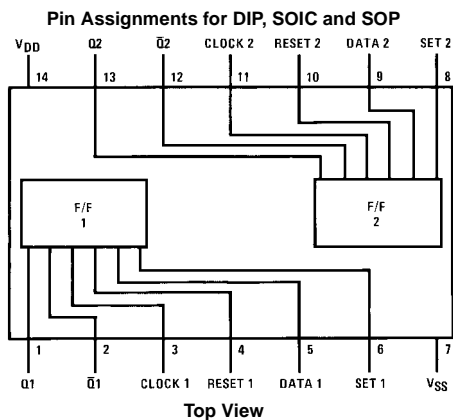

Truth Table

CL (Note 1)	D	R	S	Q	Q̄
↘	0	0	0	0	1
↗	1	0	0	1	0
↔	x	0	0	Q	Q̄
x	x	1	0	0	1
x	x	0	1	1	0
x	x	1	1	1	1

No Change
x = Don't Care Case
Note 1: Level Change

Schematic Diagrams

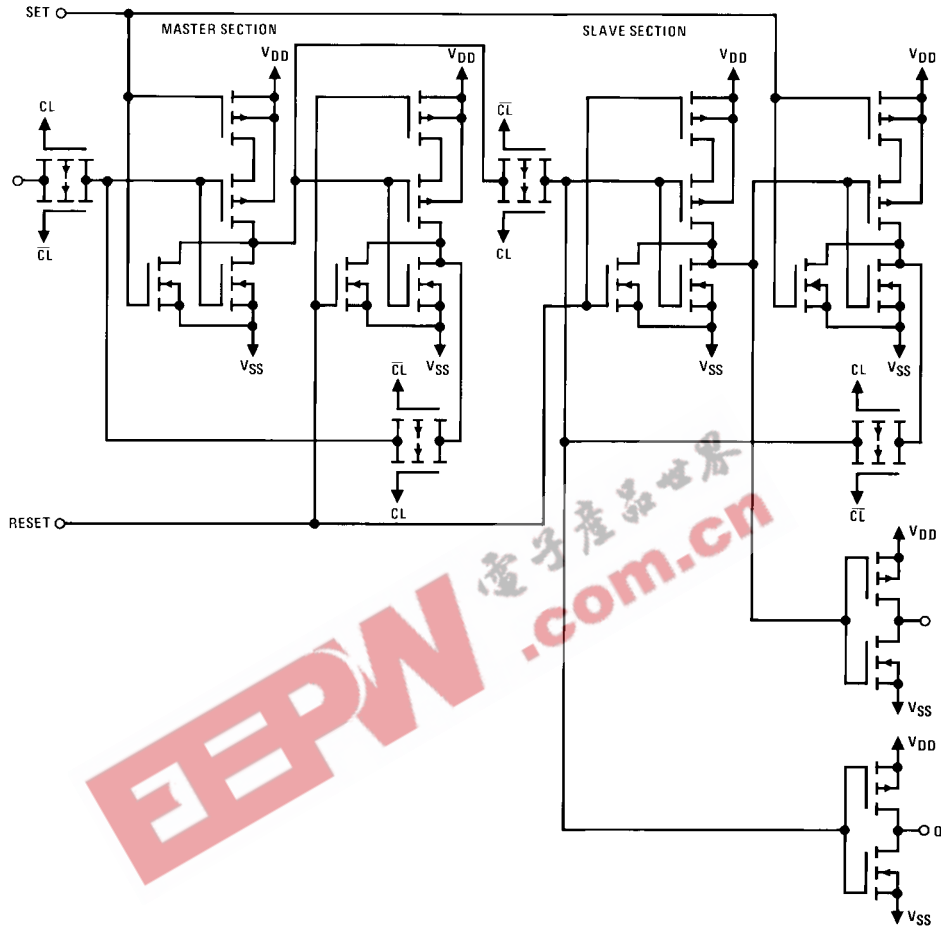

Logic Diagram

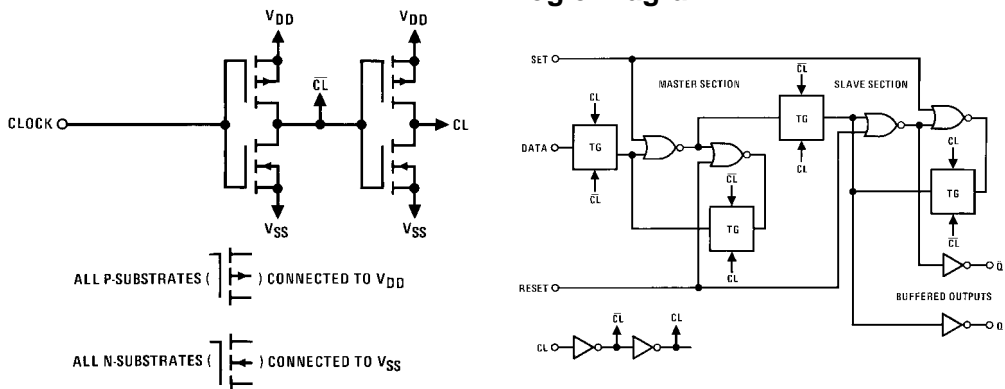

Absolute Maximum Ratings (Note 2)		Recommended Operating Conditions (Note 3)	
DC Supply Voltage (V_{DD})	-0.5 V_{DC} to +18 V_{DC}	DC Supply Voltage (V_{DD})	+3 V_{DC} to +15 V_{DC}
Input Voltage (V_{IN})	-0.5 V_{DC} to V_{DD} +0.5 V_{DC}	Input Voltage (V_{IN})	0 V_{DC} to V_{DD} V_{DC}
Storage Temperature Range (T_S)	-65°C to +150°C	Operating Temperature Range (T_A)	-40°C to +85°C
Power Dissipation (P_D)			
Dual-In-Line	700 mW		
Small Outline	500 mW		
Lead Temperature (T_L)			
(Soldering, 10 seconds)	260°C		

Note 2: "Absolute Maximum Ratings" are those values beyond which the safety of the device cannot be guaranteed, they are not meant to imply that the devices should be operated at these limits. The tables of "Recommended Operating Conditions" and "Electrical Characteristics" provide conditions for actual device operation.

Note 3: V_{SS} = 0V unless otherwise specified.

DC Electrical Characteristics (Note 3)

Symbol	Parameter	Conditions	-40°C		+25°C			+85°C		Units
			Min	Max	Min	Typ	Max	Min	Max	
I_{DD}	Quiescent Device Current	$V_{DD} = 5V, V_{IN} = V_{DD}$ or V_{SS}		4.0			4.0		30	μA
		$V_{DD} = 10V, V_{IN} = V_{DD}$ or V_{SS}		8.0			8.0		60	μA
		$V_{DD} = 15V, V_{IN} = V_{DD}$ or V_{SS}		16.0			16.0		120	μA
V_{OL}	LOW Level Output Voltage	$ I_O < 1.0 \mu A$								
		$V_{DD} = 5V$		0.05			0.05		0.05	V
		$V_{DD} = 10V$		0.05			0.05		0.05	V
V_{OH}	HIGH Level Output Voltage	$ I_O < 1.0 \mu A$								
		$V_{DD} = 5V$	4.95		4.95			4.95		V
		$V_{DD} = 10V$	9.95		9.95			9.95		V
V_{IL}	LOW Level Input Voltage	$ I_O < 1.0 \mu A$								
		$V_{DD} = 5V, V_O = 0.5V$ or $4.5V$		1.5			1.5		1.5	V
		$V_{DD} = 10V, V_O = 1.0V$ or $9.0V$		3.0			3.0		3.0	V
V_{IH}	HIGH Level Input Voltage	$ I_O < 1.0 \mu A$								
		$V_{DD} = 5V, V_O = 0.5V$ or $4.5V$	3.5		3.5			3.5		V
		$V_{DD} = 10V, V_O = 1.0V$ or $9.0V$	7.0		7.0			7.0		V
I_{OL}	LOW Level Output Current (Note 4)	$V_{DD} = 5V, V_O = 0.4V$	0.52		0.44	0.88		0.36		mA
		$V_{DD} = 10V, V_O = 0.5V$	1.3		1.1	2.25		0.9		mA
		$V_{DD} = 15V, V_O = 1.5V$	3.6		3.0	8.8		2.4		mA
I_{OH}	HIGH Level Output Current (Note 4)	$V_{DD} = 5V, V_O = 4.6V$	-0.52		-0.44	-0.88		-0.36		mA
		$V_{DD} = 10V, V_O = 9.5V$	-1.3		-1.1	-2.25		-0.9		mA
		$V_{DD} = 15V, V_O = 13.5V$	-3.6		-3.0	-8.8		-2.4		mA
I_{IN}	Input Current	$V_{DD} = 15V, V_{IN} = 0V$		-0.3		-10^{-5}		-0.3		μA
		$V_{DD} = 15V, V_{IN} = 15V$		0.3		10^{-5}		0.3		μA

Note 4: I_{OH} and I_{OL} are measured one output at a time.

AC Electrical Characteristics (Note 5)

T_A = 25°C, C_L = 50 pF, R_L = 200k, unless otherwise noted

Symbol	Parameter	Conditions	Min	Typ	Max	Units
CLOCK OPERATION						
t _{PHL} , t _{PLH}	Propagation Delay Time	V _{DD} = 5V V _{DD} = 10V V _{DD} = 15V		200 80 65	350 160 120	ns ns ns
t _{THL} , t _{TLH}	Transition Time	V _{DD} = 5V V _{DD} = 10V V _{DD} = 15V		100 50 40	200 100 80	ns ns ns
t _{WL} , t _{WH}	Minimum Clock Pulse Width	V _{DD} = 5V V _{DD} = 10V V _{DD} = 15V		100 40 32	200 80 65	ns ns ns
t _{RCL} , t _{FCL}	Maximum Clock Rise and Fall Time	V _{DD} = 5V V _{DD} = 10V V _{DD} = 15V			15 10 5	μs μs μs
t _{SU}	Minimum Set-Up Time	V _{DD} = 5V V _{DD} = 10V V _{DD} = 15V		20 15 12	40 30 25	ns ns ns
f _{CL}	Maximum Clock Frequency	V _{DD} = 5V V _{DD} = 10V V _{DD} = 15V	2.5 6.2 7.6	5 12.5 15.5		MHz MHz MHz
SET AND RESET OPERATION						
t _{PHL(R)} , t _{PLH(S)}	Propagation Delay Time	V _{DD} = 5V V _{DD} = 10V V _{DD} = 15V		150 65 45	300 130 90	ns ns ns
t _{WH(R)} , t _{WH(S)}	Minimum Set and Reset Pulse Width	V _{DD} = 5V V _{DD} = 10V V _{DD} = 15V		90 40 25	180 80 50	ns ns ns
C _{IN}	Average Input Capacitance	Any Input		5	7.5	pF

Note 5: AC Parameters are guaranteed by DC correlated testing.

Switching Time Waveforms

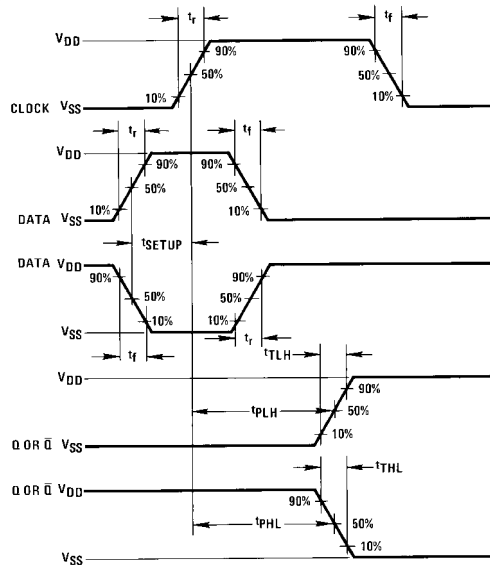

Physical Dimensions inches (millimeters) unless otherwise noted

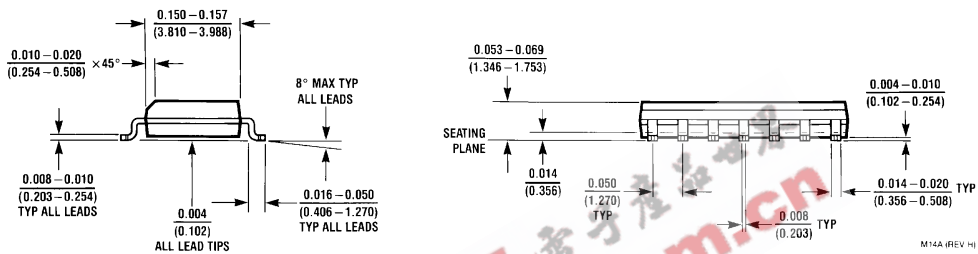
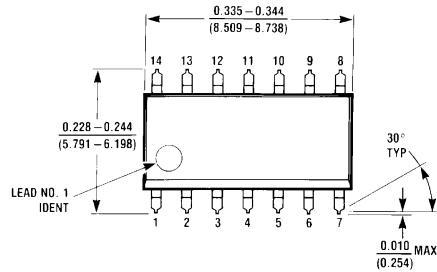

14-Lead Small Outline Integrated Circuit (SOIC), JEDEC MS-120, 0.150" Narrow
Package Number M14A

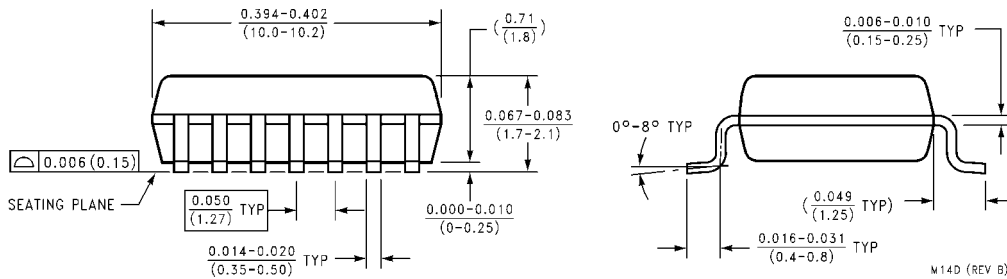
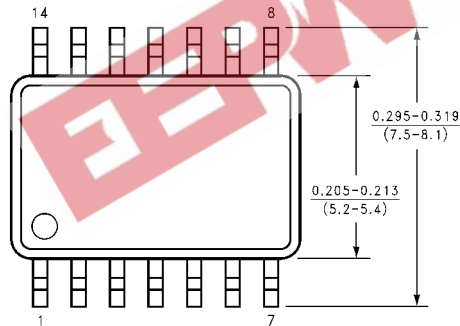

14-Lead Small Outline Package (SOP), EIAJ TYPE II, 5.3mm Wide
Package Number M14D

Physical Dimensions inches (millimeters) unless otherwise noted (Continued)

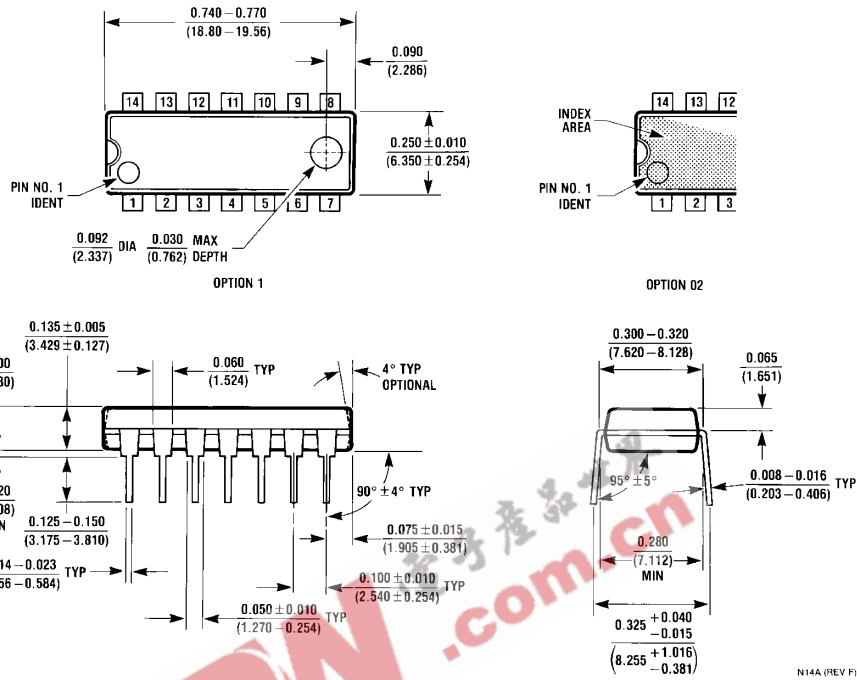

14-Lead Plastic Dual-In-Line Package (PDIP), JEDEC MS-001, 0.300" Wide Package Number N14A

N14A (REV F)

LIFE SUPPORT POLICY

FAIRCHILD'S PRODUCTS ARE NOT AUTHORIZED FOR USE AS CRITICAL COMPONENTS IN LIFE SUPPORT DEVICES OR SYSTEMS WITHOUT THE EXPRESS WRITTEN APPROVAL OF THE PRESIDENT OF FAIRCHILD SEMICONDUCTOR CORPORATION. As used herein:

1. Life support devices or systems are devices or systems which, (a) are intended for surgical implant into the body, or (b) support or sustain life, and (c) whose failure to perform when properly used in accordance with instructions for use provided in the labeling, can be reasonably expected to result in a significant injury to the user.
2. A critical component in any component of a life support device or system whose failure to perform can be reasonably expected to cause the failure of the life support device or system, or to affect its safety or effectiveness.

www.fairchildsemi.com