

**NPN SILICON PLANAR EPITAXIAL TRANSISTOR**

**CD13001**

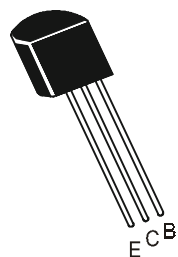

**TO - 92  
Plastic Package**

**ABSOLUTE MAXIMUM RATING (T<sub>a</sub> =25°C )**

DESCRIPTION	SYMBOL	VALUE	UNIT
Collector Base Voltage	V <sub>CBO</sub>	500	V
Collector Emitter Voltage	V <sub>CEO</sub>	400	V
Emitter Base Voltage	V <sub>EBO</sub>	9.0	V
Collector Current Continuous	I <sub>C</sub>	0.5	A
Peak (1)	I <sub>CM</sub>	1.5	
Collector Power Dissipation	P <sub>C</sub>	900	mW
Operating and Storage Junction Temperature Range	T <sub>j</sub> , T <sub>stg</sub>	- 55 to +150	°C

(1) Pulse Test: Pulse Width = 5ms, Duty Cycle ≤10%

**ELECTRICAL CHARACTERISTICS (T<sub>a</sub>=25°C unless specified otherwise)**

DESCRIPTION	SYMBOL	TEST CONDITION	MIN	TYP	MAX	UNIT
Collector Base Voltage	V <sub>CBO</sub>	I <sub>C</sub> =100μA, I <sub>E</sub> =0	500			V
Collector Emitter Voltage	V <sub>CEO</sub>	I <sub>C</sub> =1mA, I <sub>B</sub> =0	400			V
Emitter Base Voltage	V <sub>EBO</sub>	I <sub>E</sub> =100μA, I <sub>C</sub> =0	9			V
Collector Cut off Current	I <sub>CBO</sub>	V <sub>CB</sub> =500V, I <sub>E</sub> = 0			100	μA
	I <sub>CEO</sub>	V <sub>CE</sub> =400V, I <sub>B</sub> = 0			200	
Emitter Cut off Current	I <sub>EBO</sub>	V <sub>EB</sub> =9V, I <sub>C</sub> =0			100	μA
DC Current Gain	h <sub>FE</sub> *	V <sub>CE</sub> =20V, I <sub>C</sub> =20mA	10		40	
	h <sub>FE</sub>	V <sub>CE</sub> =10V, I <sub>C</sub> =0.25mA	5			
Collector Emitter Saturation Voltage	V <sub>CE(sat)</sub>	I <sub>C</sub> =50mA, I <sub>B</sub> =10mA			0.5	V
Base Emitter Saturation Voltage	V <sub>BE(sat)</sub>	I <sub>C</sub> =50mA, I <sub>B</sub> =10mA			1.2	V
Transition Frequency	f <sub>T</sub>	V <sub>CE</sub> =20V, I <sub>C</sub> =20mA, f=1MHz	8			MHz
Fall Time	t <sub>f</sub>	I <sub>C</sub> =50mA, I <sub>B1</sub> = -1, I <sub>B2</sub> =5mA			0.3	μs
Storage Time	t <sub>s</sub>	V <sub>CC</sub> =45V			1.5	

**h<sub>FE</sub>\* Classifications**

Note: Product is pre selected in DC current gain (Groups A to F). CDIL reserves the right to ship any of the groups according to production availability.	<b>A</b>	<b>B</b>	<b>C</b>	<b>D</b>	<b>E</b>	<b>F</b>
	10-15	15-20	20-25	25-30	30-35	35-40
<b>MARKING</b>	CD 13001 A	CD 13001 B	CD 13001 C	CD 13001 D	CD 13001 E	CD 13001 F

TO-92 Plastic Package

TO-92 Transistors on Tape and Ammo Pack

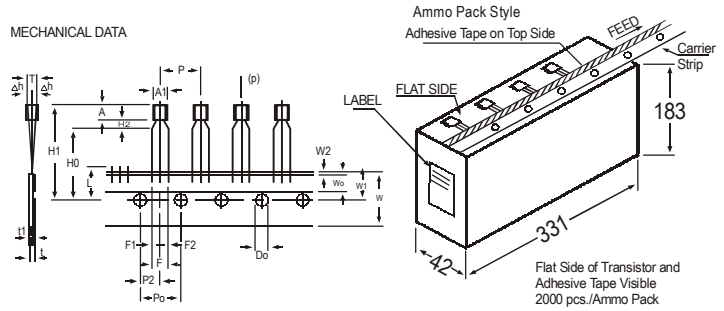
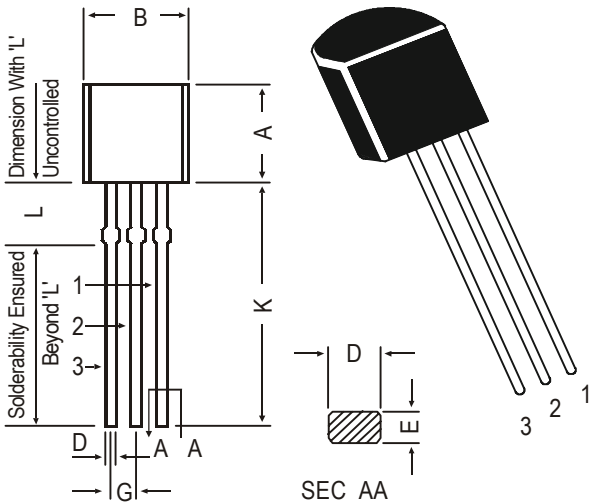

All dimensions in mm unless specified otherwise

ITEM	SYMBOL	SPECIFICATION				REMARKS
		MIN.	NOM.	MAX.	TOL.	
BODY WIDTH	A1	4.0		4.8		
BODY HEIGHT	A	4.8		5.2		
BODY THICKNESS	T	3.9		4.2		
PITCH OF COMPONENT	P		12.7		±1	CUMULATIVE PITCH ERROR 1.0 mm/20 PITCH
FEED HOLE PITCH	Po		12.7		±0.3	
FEED HOLE CENTRE TO COMPONENT CENTRE	P2		6.35		±0.4	TO BE MEASURED AT BOTTOM OF CLINCH
DISTANCE BETWEEN OUTER LEADS	F		5.08		+0.6 -0.2	AT TOP OF BODY
COMPONENT ALIGNMENT	Δh		0	1		
TAPE WIDTH	W		18		±0.5	
HOLD-DOWN TAPE WIDTH	Wo		6		±0.2	
HOLE POSITION	W1		9		+0.7 -0.5	
HOLD-DOWN TAPE POSITION	W2		0.5		±0.2	
LEAD WIRE CLINCH HEIGHT	Ho		16		±0.5	
COMPONENT HEIGHT	H1			23.25		
LENGTH OF SNIPPED LEADS	L			11.0		
FEED HOLE DIAMETER	Do		4		±0.2	t1 0.3 - 0.6
TOTAL TAPE THICKNESS	t			1.2		
LEAD - TO - LEAD DISTANCE F1,	F2		2.54		+0.4 -0.1	
CLINCH HEIGHT	H2			3		
PULL - OUT FORCE	(P)	6N				

DIM	MIN.	MAX.
A	4.32	5.33
B	4.45	5.20
C	3.18	4.19
D	0.41	0.55
E	0.35	0.50
F	5 DEG	
G	1.14	1.40
H	1.14	1.53
K	12.70	—
L	1.982	2.082

All dimensions in mm.

NOTES

1. MAXIMUM ALIGNMENT DEVIATION BETWEEN LEADS NOT TO BE GREATER THAN 0.2 mm.
2. MAXIMUM NON-CUMULATIVE VARIATION BETWEEN TAPE FEED HOLES SHALL NOT EXCEED 1 mm IN 20 PITCHES.
3. HOLD-DOWN TAPE NOT TO EXCEED BEYOND THE EDGE(S) OF CARRIER TAPE AND THERE SHALL BE NO EXPOSURE OF ADHESIVE.
4. NO MORE THAN 3 CONSECUTIVE MISSING COMPONENTS ARE PERMITTED.
5. A TAPE TRAILER, HAVING AT LEAST THREE FEED HOLES ARE REQUIRED AFTER THE LAST COMPONENT.
6. SPLICES SHALL NOT INTERFERE WITH THE SPROCKET FEED HOLES.

PIN CONFIGURATION

1. BASE
2. COLLECTOR
3. EMITTER

Packing Detail

PACKAGE	STANDARD PACK		INNER CARTON BOX		OUTER CARTON BOX		
	Details	Net Weight/Qty	Size	Qty	Size	Qty	Gr Wt
TO-92 Bulk	1K/polybag	200 gm/1K pcs	3" x 7.5" x 7.5"	5K	17" x 15" x 13.5"	80K	23 kgs
TO-92 T&A	2K/ammo box	645 gm/2K pcs	12.5" x 8" x 1.8"	2K	17" x 15" x 13.5"	32K	12.5 kgs



### Disclaimer

The product information and the selection guides facilitate selection of the CDIL's Discrete Semiconductor Device(s) best suited for application in your product(s) as per your requirement. It is recommended that you completely review our Data Sheet(s) so as to confirm that the Device(s) meet functionality parameters for your application. The information furnished in the Data Sheet and on the CDIL Web Site/CD is believed to be accurate and reliable. CDIL however, does not assume responsibility for inaccuracies or incomplete information. Furthermore, CDIL does not assume liability whatsoever, arising out of the application or use of any CDIL product; neither does it convey any license under its patent rights nor rights of others. These products are not designed for use in life saving/support appliances or systems. CDIL customers selling these products (either as individual Discrete Semiconductor Devices or incorporated in their end products), in any life saving/support appliances or systems or applications do so at their own risk and CDIL will not be responsible for any damages resulting from such sale(s).

CDIL strives for continuous improvement and reserves the right to change the specifications of its products without prior notice.



CDIL is a registered Trademark of

**Continental Device India Limited**

C-120 Naraina Industrial Area, New Delhi 110 028, India.

Telephone + 91-11-579 6150 Fax + 91-11-579 9569, 579 5290

e-mail sales@cdil.com www.cdil.com