

DESCRIPTION

The CNX48U, H11BX, MOC8080 and TIL113 have a gallium arsenide infrared emitter optically coupled to a silicon planar photodarlington.

CNX48U	H11B1	H11B2	H11B255	H11B3
MOC8080	TIL113			

FEATURES

- High sensitivity to low input drive current
- Meets or exceeds all JEDEC Registered Specifications
- VDE 0884 approval available as a test option
-add option .300. (e.g., H11B1.300)

APPLICATIONS

- Low power logic circuits
- Telecommunications equipment
- Portable electronics
- Solid state relays
- Interfacing coupling systems of different potentials and impedances.

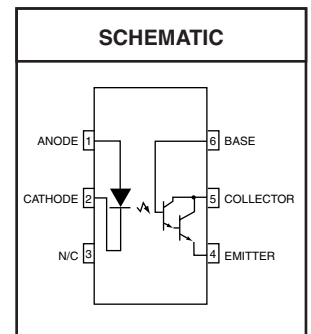
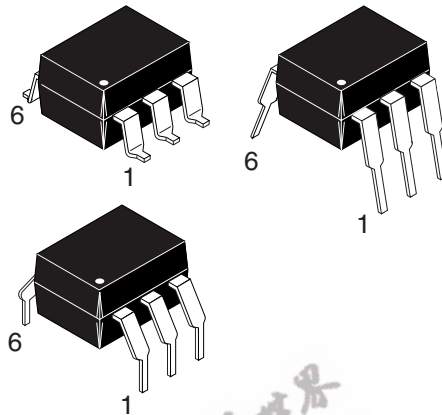

Parameter	Symbol	Device	Value	Units
TOTAL DEVICE				
Storage Temperature	T_{STG}	All	-55 to +150	°C
Operating Temperature	T_{OPR}	All	-55 to +100	°C
Lead Solder Temperature	T_{SOL}	All	260 for 10 sec	°C
Total Device Power Dissipation @ $T_A = 25^\circ\text{C}$ Derate above 25°C	P_D	All	250	mW
			3.3	mW/°C
EMITTER				
Continuous Forward Current	I_F	All	100	mA
Reverse Voltage	V_R	All	6	V
Forward Current - Peak (300 μs , 2% Duty Cycle)	$I_F(\text{pk})$	All	3.0	A
LED Power Dissipation @ $T_A = 25^\circ\text{C}$ Derate above 25°C	P_D	All	100	mW
			1.8	mW/°C
DETECTOR				
Collector-Emitter Breakdown Voltage	BV_{CEO}	CNX48U, TIL113	30	V
		H11B1, H11B2 H11B3	25	
		H11B255 MOC8080	55	
Collector-Base Breakdown Voltage	BV_{CBO}	CNX48U, H11B1 H11B2, H11B3 TIL113	30	V
		H11B255 MOC8080	55	V
Emitter-Collector Breakdown Voltage	BV_{ECO}	All	7	V
Detector Power Dissipation @ $T_A = 25^\circ\text{C}$ Derate above 25°C	P_D	All	150	mW
			2.0	mW/°C

CNX48U	H11B1	H11B2	H11B255	H11B3
MOC8080	TIL113			

ELECTRICAL CHARACTERISTICS ($T_A = 25^\circ\text{C}$ Unless otherwise specified.)

INDIVIDUAL COMPONENT CHARACTERISTICS

Parameter	Test Conditions	Symbol	Device	Min	Typ**	Max	Unit
EMITTER	Input Forward Voltage	V_F	H11B1, H11B2 H11B255 MOC8080 TIL113	0.8	1.2	1.5	V
			CNX48U		1.2	1.3	
			MOC8080	0.9	1.3	1.7	
			($I_F = 10\text{ mA}$, $T_A = 100^\circ\text{C}$)	0.7	1.05	1.4	
			($I_F = 50\text{ mA}$)	H11B3		1.35	
Reverse Leakage Current	($V_R = 6\text{ V}$)	I_R	All		0.001	10	μA
Capacitance	($V_F = 0\text{ V}$, $f = 1.0\text{ MHz}$)	C	All		50		pF
DETECTOR	Collector-Emitter Breakdown Voltage	BV_{CEO}	CNX48U	30	60		V
			TIL113				
			H11B1, H11B2 H11B3	25	60		
			H11B255 MOC8080	55	70		
			($I_C = 1\text{ mA}$, $I_F = 0$)				
Collector-Base Breakdown Voltage	($I_C = 100\text{ }\mu\text{A}$, $I_E = 0$)	BV_{CBO}	CNX48U, H11B1 H11B2, H11B3 TIL113	30	100		V
	($I_C = 100\text{ }\mu\text{A}$, $I_F = 0$)		H11B255 MOC8080	55	100		
Emitter-Collector Breakdown Voltage	($I_E = 100\text{ }\mu\text{A}$, $I_B = 0$)	BV_{ECO}	All	7	10		V
Collector-Emitter Dark Current	($V_{CE} = 10\text{ V}$, Base Open)	I_{CEO}	All		1	100	nA

Note

** Typical values at $T_A = 25^\circ\text{C}$

CNX48U	H11B1	H11B2	H11B255	H11B3
MOC8080	TIL113			

TRANSFER CHARACTERISTICS (T_A = 25°C Unless otherwise specified.)

DC Characteristics	Test Conditions	Symbol	Device	Min	Typ**	Max	Units	
Collector Output Current ⁽¹⁾	(I _F = 10 mA, V _{CE} = 5 V)	I _C (CTR)	MOC8080	50 (500)			mA (%)	
			H11B255	10 (100)				
	(I _F = 10 mA, V _{CE} = 1 V)		CNX48U	60 (600)				
			TIL113	30 (300)				
	(I _F = 1 mA, V _{CE} = 5 V)		H11B1	5 (500)				
			H11B2	2 (200)				
			H11B3	1 (100)				
	(I _F = 1 mA, V _{CE} = 1 V)	CNX48U		5 (500)				
	(I _F = 0.5 mA, V _{CE} = 1 V)			1.75 (350)				
Saturation Voltage	(I _F = 1 mA, I _C = 1 mA)	V _{CE(sat)}	H11B1, H11B2 H11B3, MOC8080			1.0	V	
	(I _F = 5 mA, I _C = 10 mA)		CNX48U			1.0		
	(I _F = 50 mA, I _C = 50 mA)		H11B255			1.0		
	(I _F = 8 mA, I _C = 2 mA)		TIL113			1.25		
AC Characteristics	(I _C = 10 mA, V _{CE} = 10 V) (R _L = 100 Ω) (Fig.7)	t _{on}	H11B1 H11B2		25		μs	
		t _{off}	H11B255 H11B3		18			
	(I _F = 10 mA, V _{CC} = 5 V) (R _E = 100 Ω), (R _{BE} = 1MΩ) (Fig. 8)	t _{on}	CNX48U			3.5		
		t _{off}				36		
	(I _F = 1 mA, V _{CC} = 5 V) (R _E = 1kΩ), (R _{BE} = 10MΩ) (Fig. 8)	t _{on}				70		
		t _{off}				190		
	(I _F = 5 mA, V _{CC} = 10 V) (R _L = 100 Ω) (Fig.7)	t _{on}	MOC8080			3.5		
		t _{off}				25		
	(I _F = 200 mA, I _C = 50 mA) (V _{CC} = 10 V) (R _L = 100 Ω) (Fig.7)	t _{on}	TIL113			0.35		5
		t _{off}				55		100

ISOLATION CHARACTERISTICS

Characteristic	Test Conditions	Symbol	Min	Typ**	Max	Units
Input-Output Isolation Voltage ⁽²⁾	(I _{I-O} ≤ 1 μA, V _{rms} , t = 1 min.)		5300			Vac(rms)
Isolation Resistance ⁽²⁾	(V _{I-O} = 500 VDC)	R _{ISO}		10 ¹¹		Ω
Isolation Capacitance ⁽²⁾	(V _{I-O} = ∅, f = 1 MHz)	C _{ISO}		0.8		pf

Note

** Typical values at T_A = 25°C

CNX48U	H11B1	H11B2	H11B255	H11B3
MOC8080	TIL113			

Fig. 1 Output Current vs. Input Current

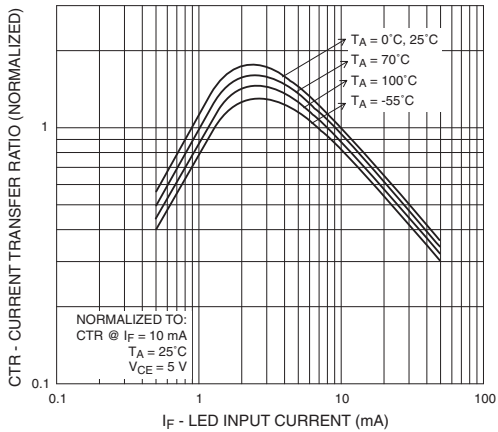

Fig. 2 Current Transfer Ratio vs. Ambient Temperature

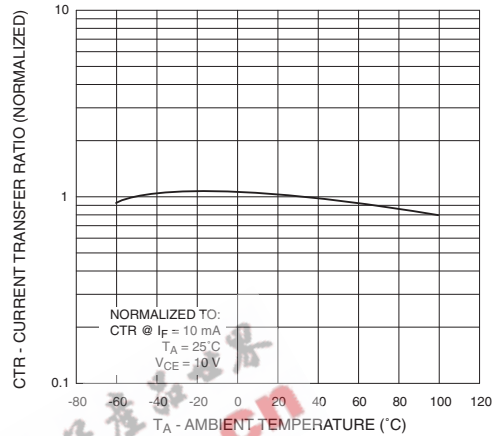

Fig. 3 Collector Current vs. Collector-Emitter Voltage

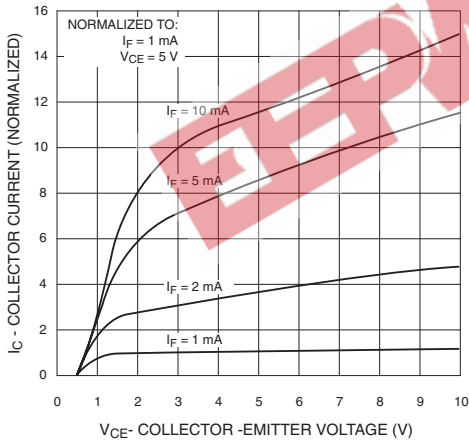

Fig. 4 Dark Current vs. Ambient Temperature

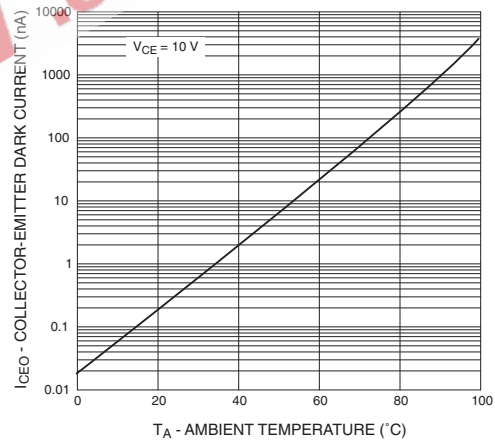

Fig. 5 Turn-On Time vs. Input Current

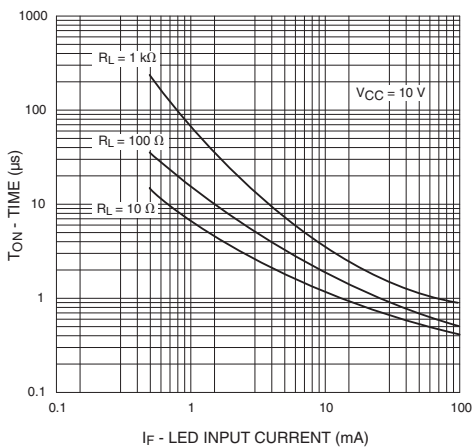
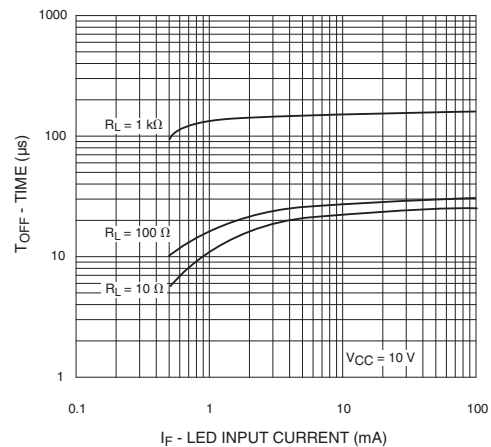

Fig. 6 Turn-Off Time vs. Input Current



CNX48U	H11B1	H11B2	H11B255	H11B3
MOC8080	TIL113			

TYPICAL ELECTRO-OPTICAL CHARACTERISTIC CURVES

(25°C Free air temperature unless otherwise specified) (Cont.)

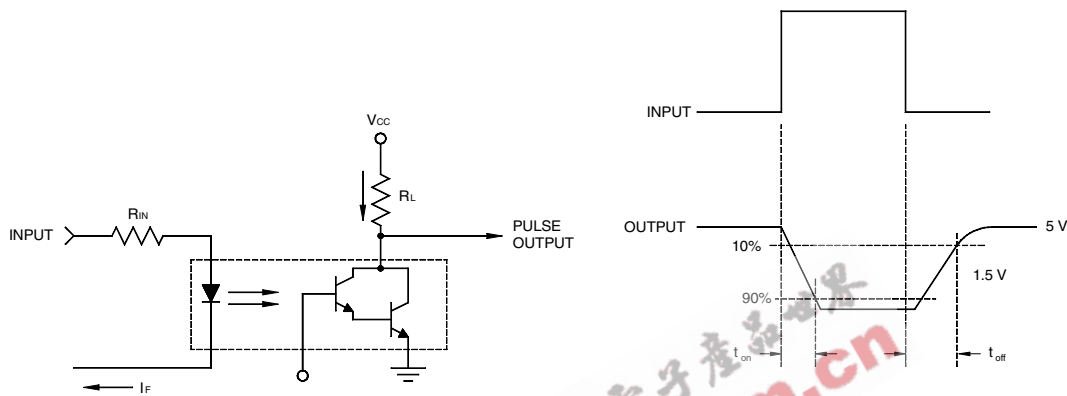

Test Circuit (All devices except CNX48U)

Switching Waveforms (All devices except CNX48U)

Fig. 7 Switching Time Test Circuit and Waveforms (All devices except CNX48U)

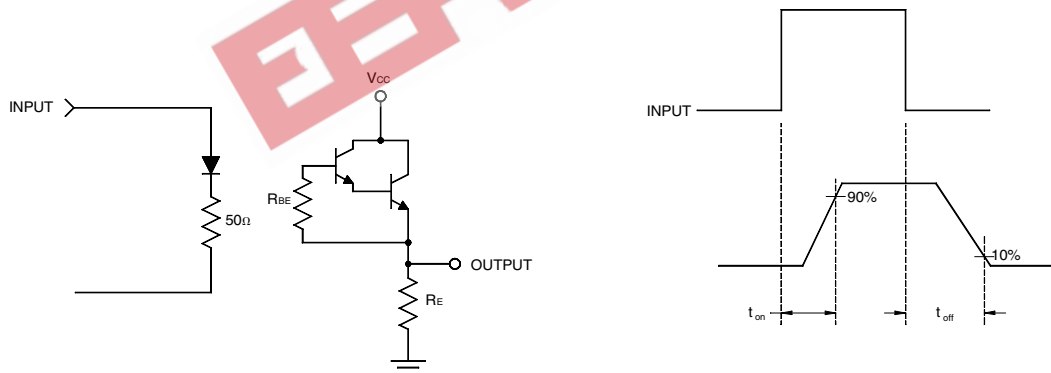

Test Circuit (CNX48U only)

Switching Waveforms (CNX48U only)

Fig. 8 Switching Time Test Circuit and Waveforms (CNX48U only)

Notes

1. The current transfer ratio (I_C/I_F) is the ratio of the detector collector current to the LED input current with V_{CE} @ 10 V.
2. For this test, LED pins 1 and 2 are common and phototransistor pins 4,5 and 6 are common.

CNX48U H11B1 H11B2 H11B255 H11B3
MOC8080 TIL113

Package Dimensions (Through Hole)

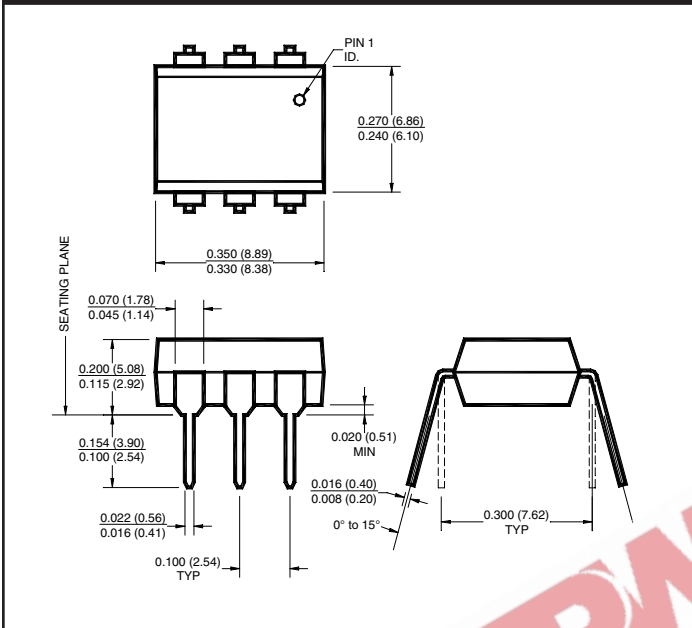

Package Dimensions (Surface Mount)

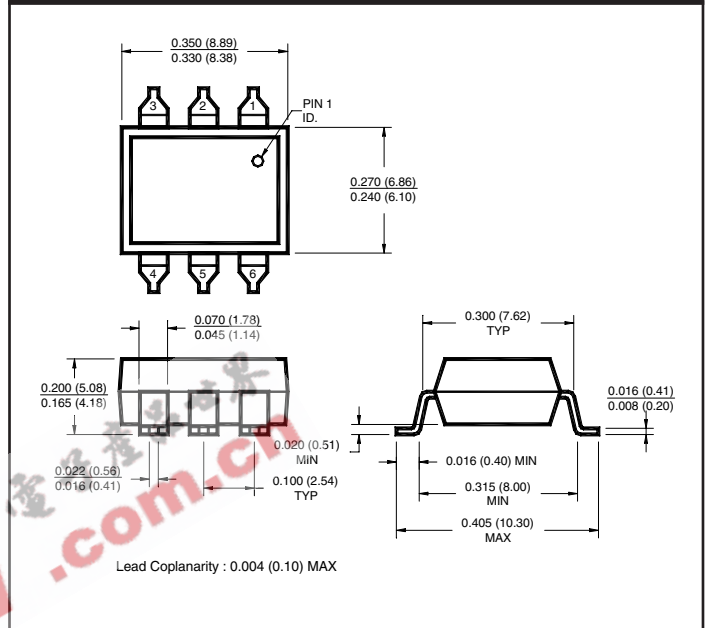

Package Dimensions (0.4" Lead Spacing)

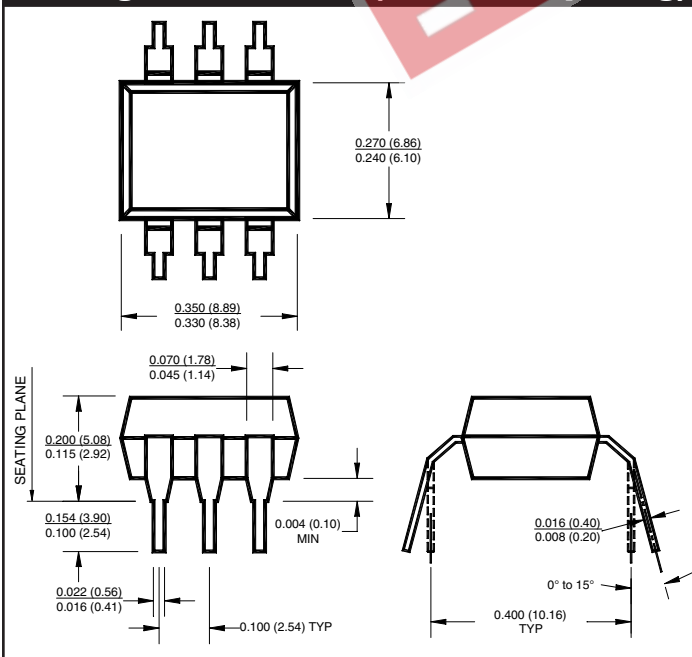

Recommended Pad Layout for Surface Mount Leadform

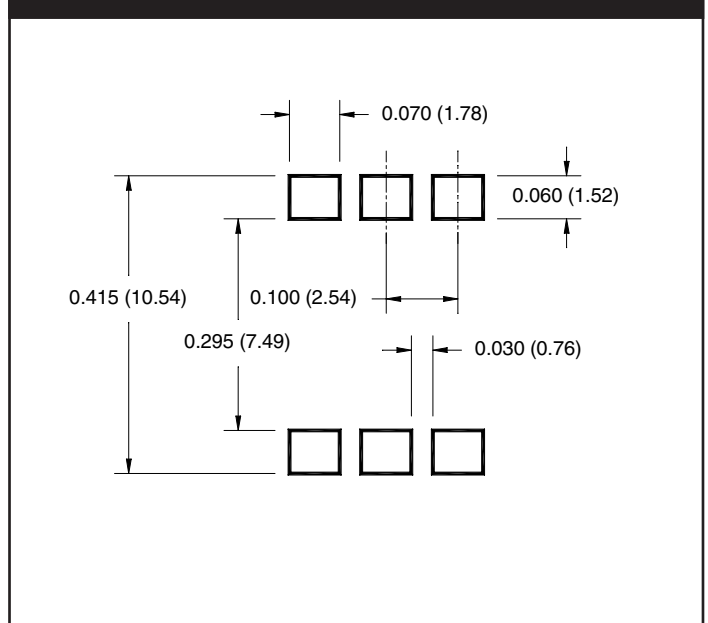

NOTE

All dimensions are in inches (millimeters)

Call QT Optoelectronics for more information or the phone number of your nearest distributor.

United States 800-533-6786 • France 33 [0] 1.45.18.78.78 • Germany 49 [0] 89/96.30.51 • United Kingdom 44 [0] 1296 394499 • Asia/Pacific 603-7248193



PHOTODARLINGTON OPTOCOUPLEDERS

CNX48U	H11B1	H11B2	H11B255	H11B3
MOC8080	TIL113			

ORDERING INFORMATION

Option	Order Entry Identifier	Description
S	.S	Surface Mount Lead Bend
SD	.SD	Surface Mount; Tape and reel
W	.W	0.4" Lead Spacing
300	.300	VDE 0884
300W	.300W	VDE 0884, 0.4" Lead Spacing
3S	.3S	VDE 0884, Surface Mount
3SD	.3SD	VDE 0884, Surface Mount, Tape & Reel

QT Carrier Tape Specifications ("D" Taping Orientation)

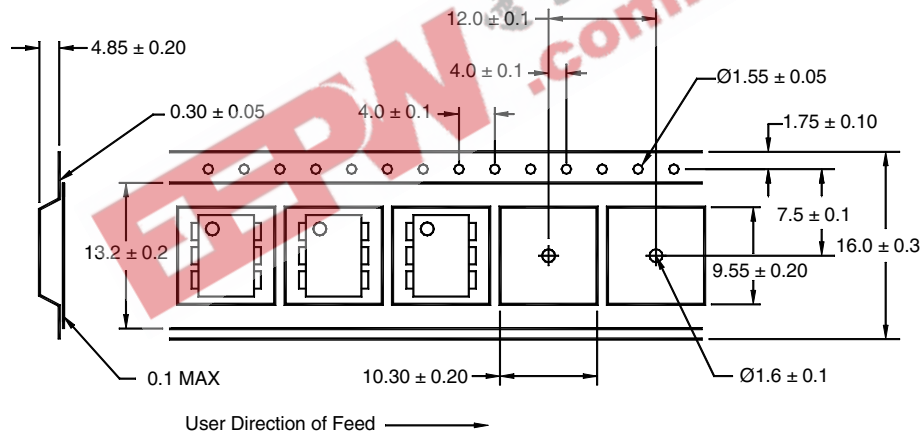

NOTE

All dimensions are millimeters

Call QT Optoelectronics for more information or the phone number of your nearest distributor.

United States 800-533-6786 • France 33 [0] 1.45.18.78.78 • Germany 49 [0] 89/96.30.51 • United Kingdom 44 [0] 1296 394499 • Asia/Pacific 603-7248193

www.qtopto.com