

Fractional-N Clock Synthesizer & Clock Multiplier

Features

- ◆ Delta-Sigma Fractional-N Frequency Synthesis
 - Generates a Low Jitter 6 - 75 MHz Clock from an 8 - 75 MHz Reference Clock
- ◆ Clock Multiplier / Jitter Reduction
 - Generates a Low Jitter 6 - 75 MHz Clock from a Jittery or Intermittent 50 Hz to 30 MHz Clock Source
- ◆ Highly Accurate PLL Multiplication Factor
 - Maximum Error Less Than 1 PPM in High-Resolution Mode
- ◆ One-Time Programmability
 - Configurable Hardware Control Pins
 - Configurable Auxiliary Output
- ◆ Flexible Sourcing of Reference Clock
 - External Oscillator or Clock Source
 - Supports Inexpensive Local Crystal
- ◆ Minimal Board Space Required
 - No External Analog Loop-filter Components

General Description

The CS2000-OTP is an extremely versatile system clocking device that utilizes a programmable phase lock loop. The CS2000-OTP is based on a hybrid analog-digital PLL architecture comprised of a unique combination of a Delta-Sigma Fractional-N Frequency Synthesizer and a Digital PLL. This architecture allows for both frequency synthesis/clock generation from a stable reference clock as well as generation of a low-jitter clock relative to an external noisy synchronization clock with frequencies as low as 50 Hz. The CS2000-OTP has many configuration options which are set once prior to runtime. At runtime there are three hardware configuration pins available for mode and feature selection.

The CS2000-OTP is available in a 10-pin MSOP package in Commercial (-10°C to +70°C) grade. Customer development kits are also available for custom device prototyping, small production programming, and device evaluation. Please see "Ordering Information" on page 30 for complete details.

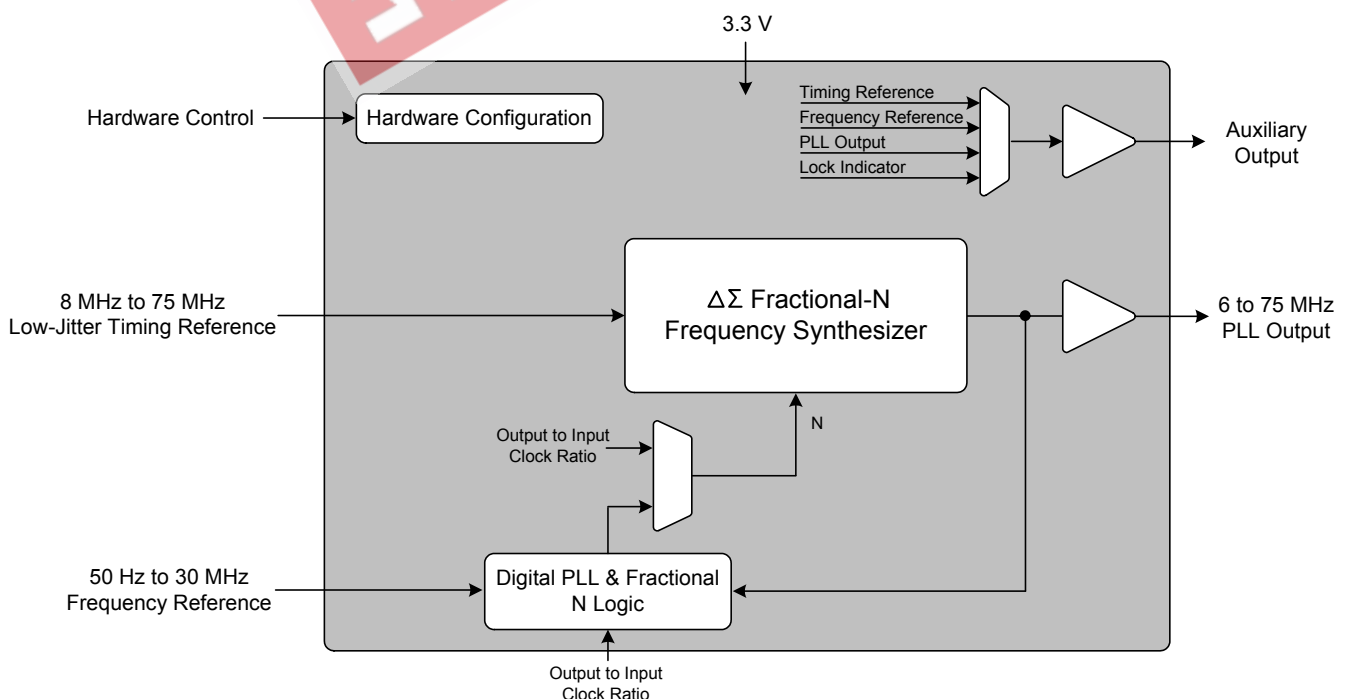

TABLE OF CONTENTS

| | |
|---|-----------|
| 1. PIN DESCRIPTION | 4 |
| 2. TYPICAL CONNECTION DIAGRAM | 5 |
| 3. CHARACTERISTICS AND SPECIFICATIONS | 6 |
| RECOMMENDED OPERATING CONDITIONS | 6 |
| ABSOLUTE MAXIMUM RATINGS | 6 |
| DC ELECTRICAL CHARACTERISTICS | 6 |
| AC ELECTRICAL CHARACTERISTICS | 7 |
| 4. ARCHITECTURE OVERVIEW | 8 |
| 4.1 Delta-Sigma Fractional-N Frequency Synthesizer | 8 |
| 4.2 Hybrid Analog-Digital Phase Locked Loop | 8 |
| 4.2.1 Fractional-N Source Selection for the Frequency Synthesizer | 9 |
| 5. APPLICATIONS | 10 |
| 5.1 One Time Programmability | 10 |
| 5.2 Timing Reference Clock Input | 10 |
| 5.2.1 Internal Timing Reference Clock Divider | 10 |
| 5.2.2 Crystal Connections (XTI and XTO) | 11 |
| 5.2.3 External Reference Clock (REF_CLK) | 11 |
| 5.3 Frequency Reference Clock Input, CLK_IN | 11 |
| 5.3.1 CLK_IN Skipping Mode | 11 |
| 5.3.2 Adjusting the Minimum Loop Bandwidth for CLK_IN | 13 |
| 5.4 Output to Input Frequency Ratio Configuration | 14 |
| 5.4.1 User Defined Ratio (RUD), Frequency Synthesizer Mode | 14 |
| 5.4.2 User Defined Ratio (RUD), Hybrid PLL Mode | 14 |
| 5.4.3 Manual Ratio Modifier (R-Mod) | 15 |
| 5.4.4 Automatic Ratio Modifier (Auto R-Mod) - Hybrid PLL Mode Only | 15 |
| 5.4.5 Effective Ratio (REFF) | 16 |
| 5.4.6 Fractional-N Source Selection | 16 |
| 5.4.6.1 Manual Fractional-N Source Selection for the Frequency Synthesizer | 17 |
| 5.4.6.2 Automatic Fractional-N Source Selection for the Frequency Synthesizer | 17 |
| 5.4.7 Ratio Configuration Summary | 18 |
| 5.5 PLL Clock Output | 19 |
| 5.6 Auxiliary Output | 19 |
| 5.7 Mode Pin Functionality | 20 |
| 5.7.1 M1 and M0 Mode Pin Functionality | 20 |
| 5.7.2 M2 Mode Pin Functionality | 20 |
| 5.7.2.1 M2 Configured as Output Disable | 20 |
| 5.7.2.2 M2 Configured as R-Mod Enable | 20 |
| 5.7.2.3 M2 Configured as Auto Fractional-N Source Selection Disable | 21 |
| 5.7.2.4 M2 Configured as Auto R-Mod Enable | 21 |
| 5.7.2.5 M2 Configured as Fractional-N Source Select | 21 |
| 5.7.2.6 M2 Configured as AuxOutSrc Override | 21 |
| 5.8 Clock Output Stability Considerations | 21 |
| 5.8.1 Output Switching | 21 |
| 5.8.2 PLL Unlock Conditions | 22 |
| 6. PARAMETER DESCRIPTIONS | 23 |
| 6.1 Modal Configuration Sets | 23 |
| 6.1.1 R-Mod Selection (RModSel[1:0]) | 23 |
| 6.1.2 Auxiliary Output Source Selection (AuxOutSrc[1:0]) | 24 |
| 6.1.3 Auto R-Modifier Enable (AutoRMod) | 24 |
| 6.1.4 Lock Clock Ratio (LockClk[1:0]) | 24 |
| 6.1.5 Fractional-N Source for Frequency Synthesizer (FracNSrc) | 24 |
| 6.2 Ratio 0 - 3 | 24 |

| | |
|--|-----------|
| 6.3 Global Configuration Parameters | 25 |
| 6.3.1 Clock Skip Enable (ClkSkipEn) | 25 |
| 6.3.2 AUX PLL Lock Output Configuration (AuxLockCfg) | 25 |
| 6.3.3 Reference Clock Input Divider (RefClkDiv[1:0]) | 25 |
| 6.3.4 Enable PLL Clock Output on Unlock (ClkOutUnl) | 25 |
| 6.3.5 Low-Frequency Ratio Configuration (LFRatioCfg) | 26 |
| 6.3.6 M2 Pin Configuration (M2Config[2:0]) | 26 |
| 6.3.7 Clock Input Bandwidth (ClkIn_BW[2:0]) | 26 |
| 7. CALCULATING THE USER DEFINED RATIO | 27 |
| 7.1 High Resolution 12.20 Format | 27 |
| 7.2 High Multiplication 20.12 Format | 27 |
| 8. PROGRAMMING INFORMATION | 28 |
| 9. PACKAGE DIMENSIONS | 29 |
| THERMAL CHARACTERISTICS | 29 |
| 10. ORDERING INFORMATION | 30 |
| 11. REVISION HISTORY | 30 |

LIST OF FIGURES

| | |
|---|----|
| Figure 1. Typical Connection Diagram | 5 |
| Figure 2. Delta-Sigma Fractional-N Frequency Synthesizer | 8 |
| Figure 3. Hybrid Analog-Digital PLL | 9 |
| Figure 4. Fractional-N Source Selection Overview | 9 |
| Figure 5. Internal Timing Reference Clock Divider | 10 |
| Figure 6. External Component Requirements for Crystal Circuit | 11 |
| Figure 7. CLK_IN removed for > 223 SysClk cycles | 12 |
| Figure 8. CLK_IN removed for < 223 SysClk cycles but > tCS | 12 |
| Figure 9. CLK_IN removed for < tCS | 13 |
| Figure 10. Low bandwidth and new clock domain | 13 |
| Figure 11. High bandwidth with CLK_IN domain re-use | 14 |
| Figure 12. Ratio Feature Summary | 18 |
| Figure 13. PLL Clock Output Options | 19 |
| Figure 14. Auxiliary Output Selection | 19 |
| Figure 15. M2 Mapping Options | 20 |
| Figure 16. Parameter Configuration Sets | 23 |

LIST OF TABLES

| | |
|--|----|
| Table 1. Modal and Global Configuration | 10 |
| Table 2. Ratio Modifier | 15 |
| Table 3. Automatic Ratio Modifier | 15 |
| Table 4. Example Audio Oversampling Clock Generation from CLK_IN | 16 |
| Table 5. Example 12.20 R-Values | 27 |
| Table 6. Example 20.12 R-Values | 27 |

1. PIN DESCRIPTION

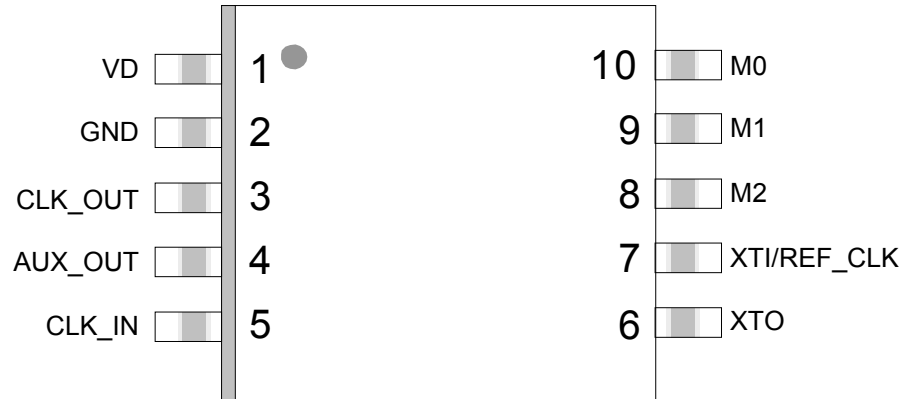

| Pin Name | # | Pin Description |
|-------------|----|---|
| VD | 1 | Digital Power (Input) - Positive power supply for the digital and analog sections. |
| GND | 2 | Ground (Input) - Ground reference. |
| CLK_OUT | 3 | PLL Clock Output (Output) - PLL clock output. |
| AUX_OUT | 4 | Auxiliary Output (Output) - This pin outputs a buffered version of one of the input or output clocks, or a status signal, depending on configuration. |
| CLK_IN | 5 | Frequency Reference Clock Input (Input) - Clock input for the Digital PLL frequency reference. |
| XTO | 6 | Crystal Connections (XTI/XTO) / Timing Reference Clock Input (REF_CLK) (Input/Output) - XTI/XTO are I/O pins for an external crystal which may be used to generate the low-jitter PLL input clock. REF_CLK is an input for an externally generated low-jitter reference clock. |
| XTI/REF_CLK | 7 | |
| M2 | 8 | Mode Select (Input) - M2 is a configurable mode selection pin. |
| M1 | 9 | Mode Select (Input) - M1 is a configurable mode selection pin. |
| M0 | 10 | Mode Select (Input) - M0 is a configurable mode selection pin. |

2. TYPICAL CONNECTION DIAGRAM

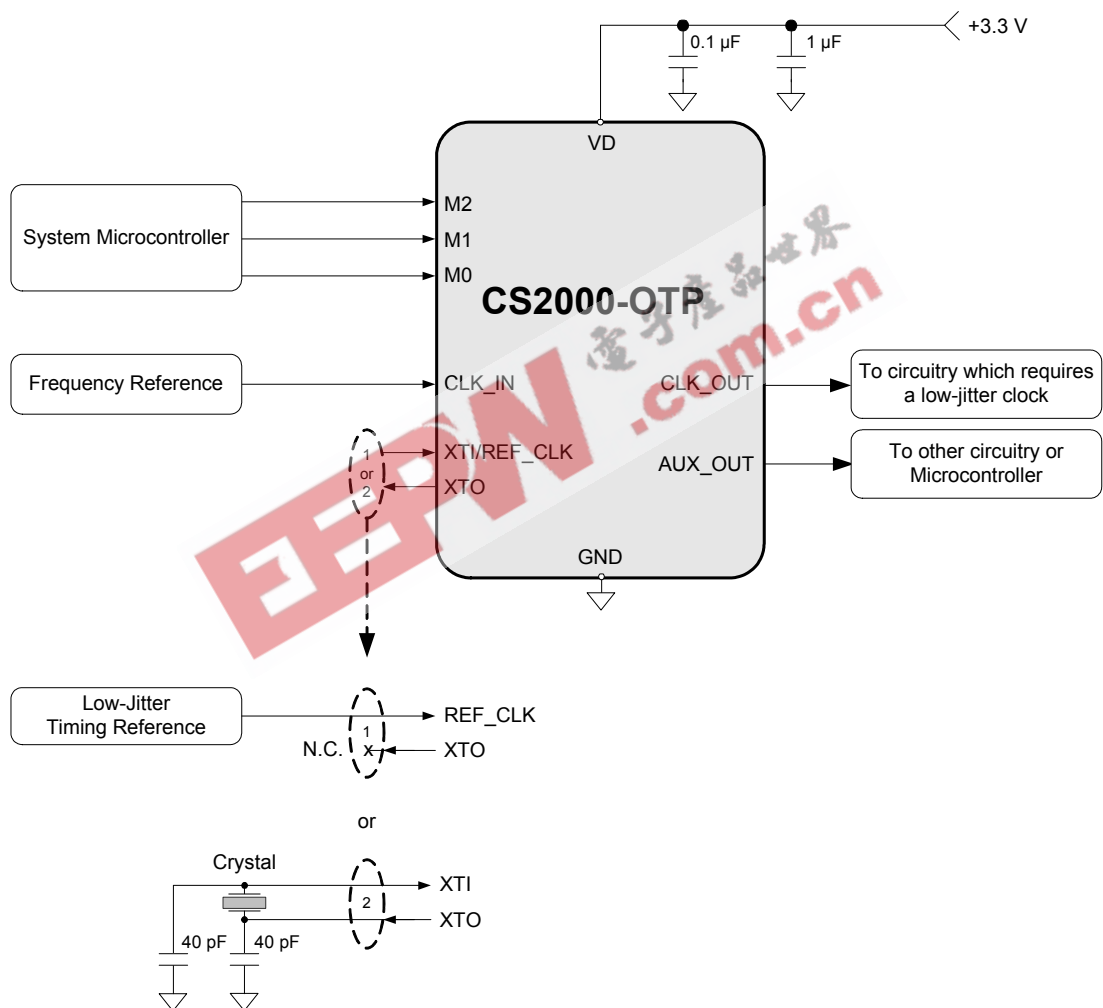

Figure 1. Typical Connection Diagram

3. CHARACTERISTICS AND SPECIFICATIONS

RECOMMENDED OPERATING CONDITIONS

GND = 0 V; all voltages with respect to ground. (Note 1)

| Parameters | Symbol | Min | Typ | Max | Units |
|---|-----------------|-----|-----|-----|-------|
| DC Power Supply | VD | 3.1 | 3.3 | 3.5 | V |
| Ambient Operating Temperature (Power Applied) Commercial Grade | T _{AC} | -10 | - | +70 | °C |

Notes: 1. Device functional operation is guaranteed within these limits. Functionality is not guaranteed or implied outside of these limits. Operation outside of these limits may adversely affect device reliability.

ABSOLUTE MAXIMUM RATINGS

GND = 0 V; all voltages with respect to ground.

| Parameters | Symbol | Min | Max | Units |
|---|------------------|------|----------|-------|
| DC Power Supply | VD | -0.3 | 6.0 | V |
| Input Current | I _{IN} | - | ±10 | mA |
| Digital Input Voltage (Note 1) | V _{IN} | -0.3 | VD + 0.4 | V |
| Ambient Operating Temperature (Power Applied) | T _A | -55 | 125 | °C |
| Storage Temperature | T _{stg} | -65 | 150 | °C |

WARNING: Operation at or beyond these limits may result in permanent damage to the device.

Notes: 1. The maximum over/under voltage is limited by the input current except on the power supply pin.

DC ELECTRICAL CHARACTERISTICS

Test Conditions (unless otherwise specified): VD = 3.1 V to 3.5 V; T_A = -10°C to +70°C (Commercial Grade).

| Parameters | Symbol | Min | Typ | Max | Units |
|---|-----------------|-----|-----|-----|-------|
| Power Supply Current - Unloaded (Note 2) | I _D | - | 12 | 18 | mA |
| Power Dissipation - Unloaded (Note 2) | P _D | - | 40 | 60 | mW |
| Input Leakage Current | I _{IN} | - | - | ±10 | µA |
| Input Capacitance | I _C | - | 8 | - | pF |
| High-Level Input Voltage | V _{IH} | 70% | - | - | VD |
| Low-Level Input Voltage | V _{IL} | - | - | 30% | VD |
| High-Level Output Voltage (I _{OH} = -1.2 mA) | V _{OH} | 80% | - | - | VD |
| Low-Level Output Voltage (I _{OH} = 1.2 mA) | V _{OL} | - | - | 20% | VD |

Notes: 2. To calculate the additional current consumption due to loading (per output pin), multiply clock output frequency by load capacitance and power supply voltage.
For example, f_{CLK_OUT} (49.152 MHz) * C_L (15 pF) * VD (3.3 V) = 2.4 mA of additional current due to these loading conditions on CLK_OUT.

AC ELECTRICAL CHARACTERISTICS

Test Conditions (unless otherwise specified): $V_D = 3.1\text{ V to }3.5\text{ V}$; $T_A = -10^\circ\text{C to }+70^\circ\text{C}$ (Commercial Grade); $C_L = 15\text{ pF}$.

| Parameters | Symbol | Conditions | Min | Typ | Max | Units |
|---|-----------------|--|-------|-----|-----------|--------|
| Crystal Frequency | f_{XTAL} | Fundamental Mode | 8 | - | 50 | MHz |
| Reference Clock Input Frequency | f_{REF_CLK} | | 8 | - | 75 | MHz |
| Reference Clock Input Duty Cycle | D_{REF_CLK} | | 45 | - | 55 | % |
| Internal System Clock Frequency | f_{SYS_CLK} | | 8 | | 18.75 | MHz |
| Clock Input Frequency (Auto R-Mod Disabled) | f_{CLK_IN} | | 50 Hz | - | 30 | MHz |
| Clock Input Frequency (Auto R-mod Enabled) | f_{CLK_IN} | Auto R Modifier = 1 | 4 | - | 59 | kHz |
| | | Auto R Modifier = 0.5 | 72 | - | 138 | kHz |
| | | Auto R Modifier = 0.25 | 168 | - | 256 | kHz |
| Clock Input Pulse Width (Note 3) | PW_{CLK_IN} | $f_{CLK_IN} < f_{SYS_CLK}/96$ | 2 | - | - | UI |
| | | $f_{CLK_IN} > f_{SYS_CLK}/96$ | 10 | - | - | ns |
| Clock Skipping Timeout | t_{CS} | (Notes 4, 5) | 20 | - | - | ms |
| Clock Skipping Input Frequency | f_{CLK_SKIP} | (Note 5) | 50 Hz | - | 80 | kHz |
| PLL Clock Output Frequency | f_{CLK_OUT} | | 6 | - | 75 | MHz |
| PLL Clock Output Duty Cycle | t_{OD} | Measured at $V_D/2$ | 48 | 50 | 52 | % |
| Clock Output Rise Time | t_{OR} | 20% to 80% of V_D | - | 1.7 | 3.0 | ns |
| Clock Output Fall Time | t_{OF} | 80% to 20% of V_D | - | 1.7 | 3.0 | ns |
| Period Jitter | t_{JIT} | (Note 6) | - | 70 | 150 | ps rms |
| Base Band Jitter (100 Hz to 40 kHz) | | (Notes 6, 7) | - | 50 | - | ps rms |
| Wide Band Jitter (100 Hz Corner) | | (Notes 6, 8) | - | 175 | - | ps rms |
| PLL Lock Time - CLK_IN (Note 9) | t_{LC} | $f_{CLK_IN} < 200\text{ kHz}$ | - | 100 | 200 | UI |
| | | $f_{CLK_IN} > 200\text{ kHz}$ | - | 1 | 3 | ms |
| PLL Lock Time - REF_CLK | t_{LR} | $f_{REF_CLK} = 8\text{ to }75\text{ MHz}$ | - | 1 | 2 | ms |
| Output Frequency Synthesis Resolution (Note 10) | f_{err} | High Resolution | 0 | - | ± 0.5 | ppm |
| | | High Multiplication | 0 | - | ± 112 | ppm |

- Notes:**
- 1 UI (unit interval) corresponds to t_{SYS_CLK} or $1/f_{SYS_CLK}$.
 - t_{CS} represents the time from the removal of CLK_IN by which CLK_IN must be re-applied to ensure that PLL_OUT continues while the PLL re-acquires lock. This timeout is based on the internal VCO frequency, with the minimum timeout occurring at the maximum VCO frequency. Lower VCO frequencies will result in larger values of t_{CS} .
 - Only valid in clock skipping mode; See “[CLK_IN Skipping Mode](#)” on page 11 for more information.
 - $f_{CLK_OUT} = 24.576\text{ MHz}$; Sample size = 10,000 points; $AuxOutSrc[1:0] = 11$.
 - In accordance with AES-12id-2006 section 3.4.2. Measurements are Time Interval Error taken with 3rd order 100 Hz to 40 kHz bandpass filter.
 - In accordance with AES-12id-2006 section 3.4.1. Measurements are Time Interval Error taken with 3rd order 100 Hz Highpass filter.
 - 1 UI (unit interval) corresponds to t_{CLK_IN} or $1/f_{CLK_IN}$.
 - The frequency accuracy of the PLL clock output is directly proportional to the frequency accuracy of the reference clock.

4. ARCHITECTURE OVERVIEW

4.1 Delta-Sigma Fractional-N Frequency Synthesizer

The core of the CS2000 is a Delta-Sigma Fractional-N Frequency Synthesizer which has very high-resolution for Input/Output clock ratios, low phase noise, very wide range of output frequencies and the ability to quickly tune to a new frequency. In very simplistic terms, the Fractional-N Frequency Synthesizer multiplies the Timing Reference Clock by the value of N to generate the PLL output clock. The desired output to input clock ratio is the value of N that is applied to the delta-sigma modulator (see [Figure 2](#)).

The analog PLL based frequency synthesizer uses a low-jitter timing reference clock as a time and phase reference for the internal voltage controlled oscillator (VCO). The phase comparator compares the fractional-N divided clock with the original timing reference and generates a control signal. The control signal is filtered by the internal loop filter to generate the VCO's control voltage which sets its output frequency. The delta-sigma modulator modulates the loop integer divide ratio to get the desired fractional ratio between the reference clock and the VCO output (thus the duty cycle of the modulator sets the fractional value). This allows the design to be optimized for very fast lock times for a wide range of output frequencies without the need for external filter components. As with any Fractional-N Frequency Synthesizer the timing reference clock should be stable and jitter-free.

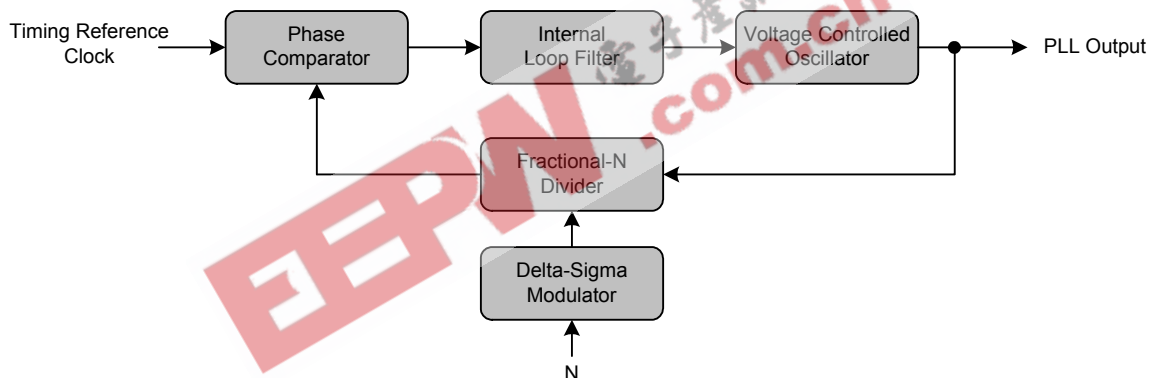

Figure 2. Delta-Sigma Fractional-N Frequency Synthesizer

4.2 Hybrid Analog-Digital Phase Locked Loop

The addition of the Digital PLL and Fractional-N Logic (shown in [Figure 3](#)) to the Fractional-N Frequency Synthesizer creates the Hybrid Analog-Digital Phase Locked Loop with many advantages over classical analog PLL techniques. These advantages include the ability to operate over extremely wide frequency ranges without the need to change external loop filter components while maintaining impressive jitter reduction performance. In the Hybrid architecture, the Digital PLL calculates the ratio of the PLL output clock to the frequency reference and compares that to the desired ratio. The digital logic generates a value of N which is then applied to the Fractional-N frequency synthesizer to generate the desired PLL output frequency. Notice that the frequency and phase of the timing reference signal do not affect the output of the PLL since the digital control loop will correct for the PLL output. A major advantage of the Digital PLL is the ease with which the loop filter bandwidth can be altered. The PLL bandwidth is set to a wide-bandwidth mode to quickly achieve lock and then reduced for optimal jitter rejection.

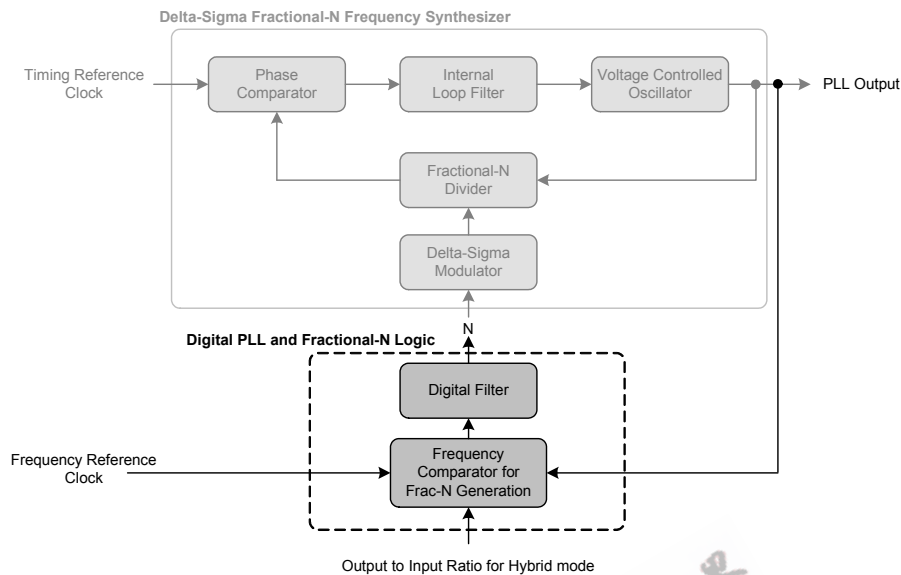

Figure 3. Hybrid Analog-Digital PLL

4.2.1 Fractional-N Source Selection for the Frequency Synthesizer

The fractional-N value for the frequency synthesizer can be sourced from either a static ratio or a dynamic ratio generated from the digital PLL (see Figure 4). This allows for the selection between operating in the static ratio based Frequency Synthesizer Mode as a simple frequency synthesizer (for frequency generation from the Timing Reference Clock) and in the dynamic ratio based Hybrid PLL Mode (for jitter reduction and clock multiplication). Selection between these two modes can either be made automatically based on the presence of the Frequency Reference Clock or manually through the mode select pins.

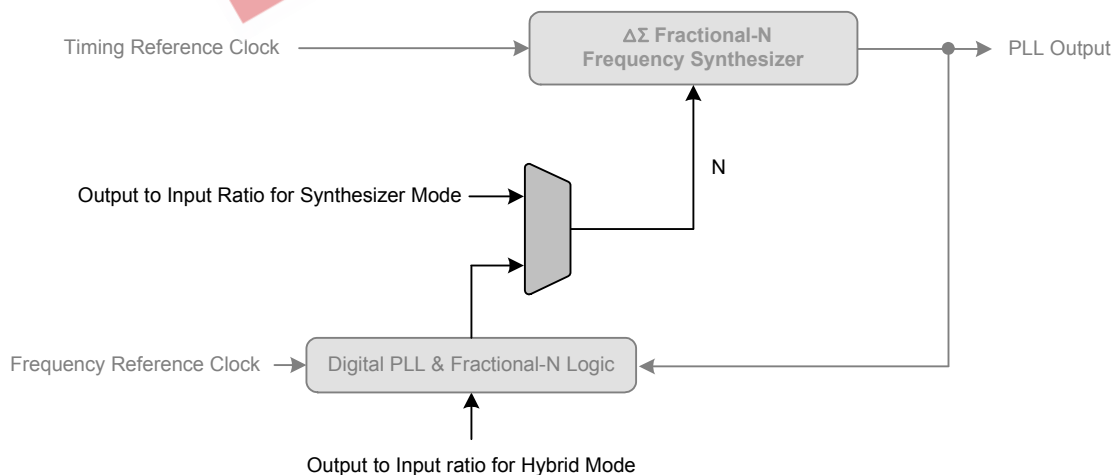

Figure 4. Fractional-N Source Selection Overview

5. APPLICATIONS

5.1 One Time Programmability

The one time programmable (OTP) circuitry in the CS2000-OTP allows for pre-configuration of the device prior to use in a system. There are two types of parameters that are used for device pre-configuration: *modal* and *global*. The *modal* parameters are features which, when grouped together, create a modal configuration set (see [Figure 16 on page 23](#)). Up to four modal configuration sets can be permanently stored and then dynamically selected using the M[1:0] mode select pins (see [Table 1](#)). The *global* parameters are the remaining configuration settings which do not change with the mode select pins. The modal and global parameters can be pre-set at the factory or user programmed using the customer development kit, CDK2000; Please see [“Programming Information” on page 28](#) for more details.

| Parameter Type | M[1:0] pins = 00 | M[1:0] pins = 01 | M[1:0] pins = 10 | M[1:0] pins = 11 |
|----------------|--|--------------------------------|--------------------------------|--------------------------------|
| Modal | Configuration Set 0 Ratio 0 | Configuration Set 1 Ratio 1 | Configuration Set 2 Ratio 2 | Configuration Set 3 Ratio 3 |
| Global | Configuration settings set once for all modes. | | | |

Table 1. Modal and Global Configuration

5.2 Timing Reference Clock Input

The low jitter timing reference clock (RefClk) can be provided by either an external reference clock or an external crystal in conjunction with the internal oscillator. In order to maintain a stable and low-jitter PLL output the timing reference clock must also be stable and low-jitter; the quality of the timing reference clock directly affects the performance of the PLL and hence the quality of the PLL output.

5.2.1 Internal Timing Reference Clock Divider

The Internal Timing Reference Clock (SysClk) is limited to a lower maximum frequency than that allowed on the XT1/REF_CLK pin. The CS2000-OTP supports the wider external frequency range by offering an internal divider for RefClk. The RefClkDiv[1:0] global parameter should be configured such that SysClk, the divided RefClk, then falls within the valid range as indicated in [Figure 5](#).

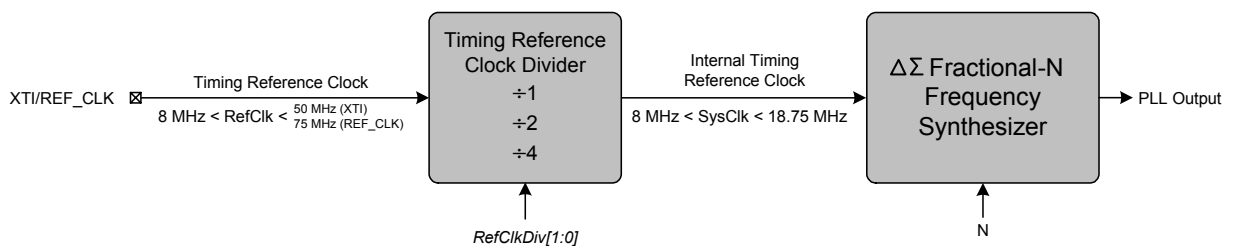

Figure 5. Internal Timing Reference Clock Divider

It should be noted that the maximum allowable input frequency of the XT1/REF_CLK pin is dependent upon its configuration as either a crystal connection or external clock input. See the [“AC Electrical Characteristics” on page 7](#) for more details.

| Referenced Control | Parameter Definition |
|--------------------|---|
| RefClkDiv[1:0] | “Reference Clock Input Divider (RefClkDiv[1:0])” on page 25 |

5.2.2 Crystal Connections (XTI and XTO)

An external crystal may be used to generate RefClk. To accomplish this, a 20 pF fundamental mode parallel resonant crystal must be connected between the XTI and XTO pins as shown in Figure 6. As shown, nothing other than the crystal and its load capacitors should be connected to XTI and XTO. Please refer to the “AC Electrical Characteristics” on page 7 for the allowed crystal frequency range.

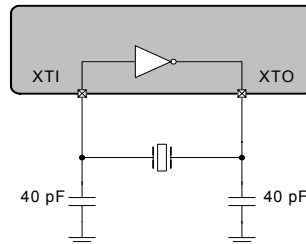

Figure 6. External Component Requirements for Crystal Circuit

5.2.3 External Reference Clock (REF_CLK)

For operation with an externally generated REF_CLK signal, XTI/REF_CLK should be connected to the reference clock source and XTO should be left unconnected or terminated through a 47 kΩ resistor to GND.

5.3 Frequency Reference Clock Input, CLK_IN

The frequency reference clock input (CLK_IN) is used in Hybrid PLL Mode by the Digital PLL and Fractional-N Logic block to dynamically generate a fractional-N value for the Frequency Synthesizer (see “Hybrid Analog-Digital PLL” on page 9). The Digital PLL first compares the CLK_IN frequency to the PLL output. The Fractional-N logic block then translates the desired ratio based off of CLK_IN to one based off of the internal timing reference clock (SysClk). This allows the low-jitter timing reference clock to be used as the clock which the Frequency Synthesizer multiplies while maintaining synchronicity with the frequency reference clock through the Digital PLL. The allowable frequency range for CLK_IN is found in the “AC Electrical Characteristics” on page 7.

5.3.1 CLK_IN Skipping Mode

CLK_IN skipping mode allows the PLL to maintain lock even when the CLK_IN signal has missing pulses for up to 20 ms (t_{CS}) at a time (see “AC Electrical Characteristics” on page 7 for specifications). CLK_IN skipping mode can only be used when the CLK_IN frequency is below 80 kHz. The *ClkSkipEn* global parameter enables this function.

Regardless of the setting of the *ClkSkipEn* parameter the PLL output will continue for 2^{23} SysClk cycles (466 ms to 1048 ms) after CLK_IN is removed (see Figure 7). This is true as long as CLK_IN does not glitch or have an effective change in period as the clock source is removed, otherwise the PLL will interpret this as a change in frequency causing clock skipping and the 2^{23} SysClk cycle time-out to be bypassed and the PLL to immediately unlock. If the prior conditions are met while CLK_IN is removed and 2^{23} SysClk cycles pass, the PLL will unlock and the PLL_OUT state will be determined by the *ClkOutUnl* parameter; See “PLL Clock Output” on page 19. If CLK_IN is re-applied after such time, the PLL will re-

main unlocked for the specified time listed in the “AC Electrical Characteristics” on page 7 after which lock will be acquired and the PLL output will resume.

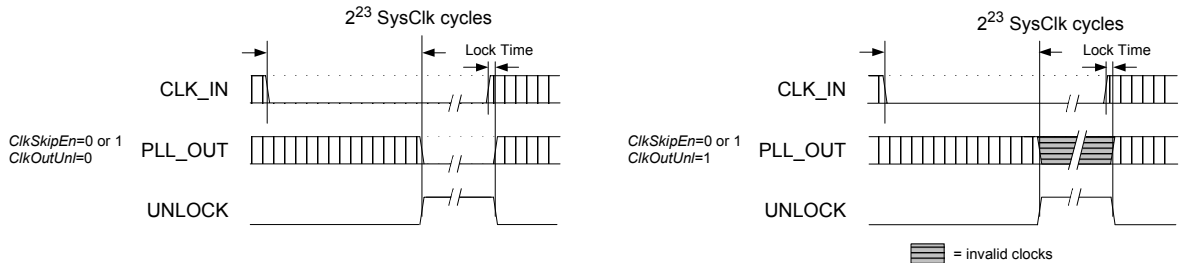

Figure 7. CLK_IN removed for > 2²³ SysClk cycles

If CLK_IN is removed and then reapplied within 2²³ SysClk cycles but later than t_{CS}, the ClkSkipEn parameter will have no effect and the PLL output will continue until CLK_IN is re-applied (see Figure 8). Once CLK_IN is re-applied, the PLL will go unlocked only for the time it takes to acquire lock; the PLL_OUT state will be determined by the ClkOutUnl parameter during this time.

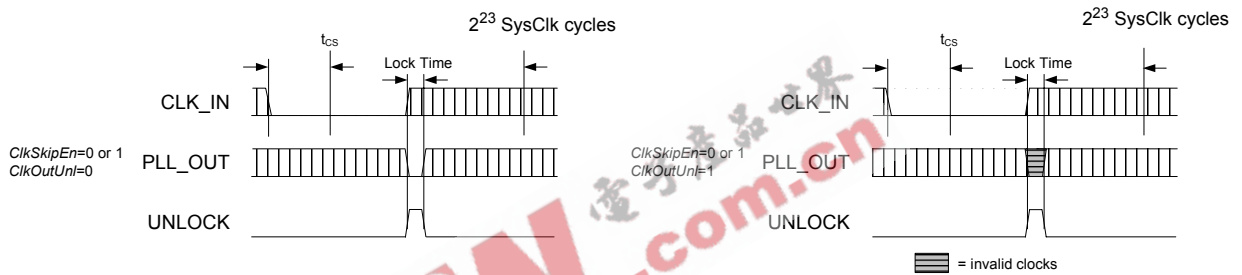

Figure 8. CLK_IN removed for < 2²³ SysClk cycles but > t_{CS}

If CLK_IN is removed and then re-applied within t_{CS}, the ClkSkipEn parameter determines whether PLL_OUT continues while the PLL re-acquires lock (see Figure 9). When ClkSkipEn is disabled and CLK_IN is removed the PLL output will continue until CLK_IN is re-applied at which point the PLL will go unlocked only for the time it takes to acquire lock; the PLL_OUT state will be determined by the ClkOutUnl parameter during this time. When ClkSkipEn is enabled and CLK_IN is removed the PLL output clock will

remain continuous throughout the missing CLK_IN period including the time while the PLL re-acquires lock.

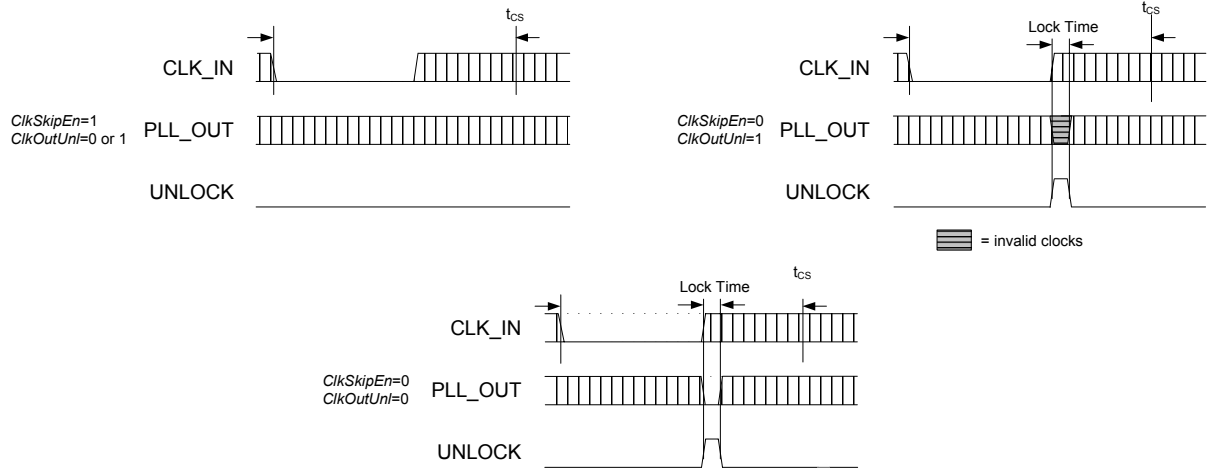

Figure 9. CLK_IN removed for t_{cs}

| Referenced Control | Parameter Definition |
|--------------------|--|
| ClkSkipEn..... | "Clock Skip Enable (ClkSkipEn)" on page 25 |
| ClkOutUnl..... | "Enable PLL Clock Output on Unlock (ClkOutUnl)" on page 25 |

5.3.2 Adjusting the Minimum Loop Bandwidth for CLK_IN

The CS2000 allows the minimum loop bandwidth of the Digital PLL to be adjusted between 1 Hz and 128 Hz using the *ClkIn_BW[2:0]* global parameter. The minimum loop bandwidth of the Digital PLL directly affects the jitter transfer function; specifically, jitter frequencies below the loop bandwidth corner are passed from the PLL input directly to the PLL output without attenuation. In some applications it is desirable to have a very low minimum loop bandwidth to reject very low jitter frequencies, commonly referred to as wander. In others it may be preferable to remove only higher frequency jitter, allowing the input wander to pass through the PLL without attenuation.

Typically, applications in which the PLL_OUT signal creates a new clock domain from which all other system clocks and associated data are derived will benefit from the maximum jitter and wander rejection of the lowest PLL bandwidth setting. See Figure 10.

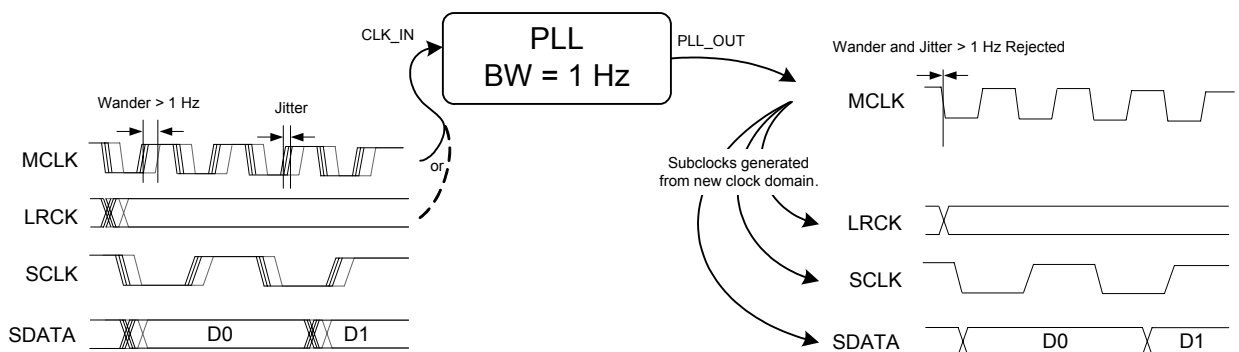

Figure 10. Low bandwidth and new clock domain

Systems in which some clocks and data are derived from the PLL_OUT signal while other clocks and data are derived from the CLK_IN signal will often require phase alignment of all the clocks and data in the system. See Figure 11. If there is substantial wander on the CLK_IN signal in these applications, it may be necessary to increase the minimum loop bandwidth allowing this wander to pass through to the

CLK_OUT signal in order to maintain phase alignment. For these applications, it is advised to experiment with the loop bandwidth settings and choose the lowest bandwidth setting that does not produce system timing errors due to wandering between the clocks and data synchronous to the CLK_IN domain and those synchronous to the PLL_OUT domain.

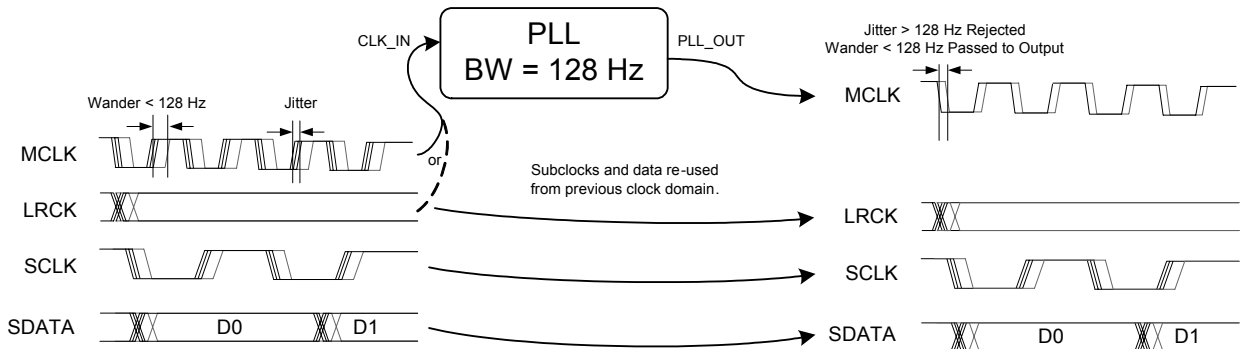

Figure 11. High bandwidth with CLK_IN domain re-use

While acquiring lock, the digital loop bandwidth is automatically set to a large value. Once lock is achieved, the digital loop bandwidth will settle to the minimum value selected by the *ClkIn_BW[2:0]* parameter.

| Referenced Control | Parameter Definition |
|--------------------|--|
| ClkIn_BW[2:0] | “Clock Input Bandwidth (ClkIn_BW[2:0])” on page 26 |

5.4 Output to Input Frequency Ratio Configuration

5.4.1 User Defined Ratio (R_{UD}), Frequency Synthesizer Mode

The User Defined Ratio, R_{UD} , is a 32-bit un-signed fixed-point number which determines the basis for the desired input to output clock ratio. Up to four different ratios, $Ratio_{0-3}$, can be stored in the CS2000’s one time programmable memory. Selection between the four ratios is achieved by the M[1:0] mode select pins. The 32-bit R_{UD} is represented in a high-resolution 12.20 format where the 12 MSBs represent the integer binary portion while the remaining 20 LSBs represent the fractional binary portion. The maximum multiplication factor is approximately 4096 with a resolution of 0.954 PPM in this configuration. See “Calculating the User Defined Ratio” on page 27 for more information.

The status of internal dividers, such as the internal timing reference clock divider, are automatically taken into account. Therefore R_{UD} is simply the desired ratio of the output to input clock frequencies.

| Referenced Control | Parameter Definition |
|--------------------|---|
| Ratio 0-3 | “Ratio 0 - 3” on page 24 |
| M[1:0] | “M1 and M0 Mode Pin Functionality” on page 20 |

5.4.2 User Defined Ratio (R_{UD}), Hybrid PLL Mode

The same four ratio locations, $Ratio_{0-3}$, are used to store the User Defined Ratios for Hybrid PLL Mode. Selection of the User Defined Ratio for the dynamic ratio based Hybrid PLL Mode is made with the M[1:0] pins (unless auto fractional N source selection is enabled; see section 5.4.6 on page 16).

In addition to the High-Resolution ratio format, a High-Multiplication format is also available. In the High-Multiplication format mode, the 32-bit fixed-point number for R_{UD} is represented in a 20.12 format where the 20 MSBs represent the integer binary portion while the remaining 12 LSBs represent the fractional

binary portion. In this configuration, the maximum multiplication factor is approximately 1,048,575 with a resolution of 244 PPM.

The 20.12 format is enabled by the *LFRatioCfg* global parameter. The 20.12 ratio format is only available when the device is running in Hybrid PLL Mode. In Auto Fractional-N Source Selection Mode (see [section 5.4.6.2 on page 17](#)) when CLK_IN is not present the *LFRatioCfg* parameter is ignored and the ratio format is 12.20.

It is recommended that the 12.20 High-Resolution format be utilized whenever the desired ratio is less than 4096 since the output frequency accuracy of the PLL is directly proportional to the accuracy of the timing reference clock and the resolution of the R_{UD}.

| Referenced Control | Parameter Definition |
|--------------------|---|
| LockClk[1:0] | “Lock Clock Ratio (LockClk[1:0])” section on page 24 |
| LFRatioCfg | “Low-Frequency Ratio Configuration (LFRatioCfg)” on page 26 |
| FracNSrc | “Fractional-N Source for Frequency Synthesizer (FracNSrc)” section on page 24 |

5.4.3 Manual Ratio Modifier (R-Mod)

The manual Ratio Modifier is used to internally multiply/divide the currently addressed R_{UD} (*Ratio*₀₋₃ stored in the register space remain unchanged). The available options for R-Mod are summarized in [Table 2 on page 15](#). R-Mod is enabled via the M2 pin in conjunction with the appropriate setting of the *M2Config[2:0]* global parameter (see [Section 5.7.2 on page 20](#)).

| RModSel[1:0] | R Modifier |
|--------------|------------|
| 00 | 0.5 |
| 01 | 0.25 |
| 10 | 0.125 |
| 11 | 0.0625 |

Table 2. Ratio Modifier

| Referenced Control | Parameter Definition |
|---------------------|---|
| Ratio 0-3 | “Ratio 0 - 3” on page 24 |
| RModSel[1:0] | “R-Mod Selection (RModSel[1:0])” section on page 23 |
| M2Config[2:0] | “M2 Pin Configuration (M2Config[2:0])” on page 26 |

5.4.4 Automatic Ratio Modifier (Auto R-Mod) - Hybrid PLL Mode Only

The Automatic R-Modifier uses the CLK_IN Frequency Range Detector to implement a frequency dependent multiply of the currently addressed R_{UD} as shown in [Table 3](#). The CLK_IN Frequency Range Detector determines the ratio between the frequency of the internal SysClk and the CLK_IN input signal. The result of the ratio measurement is the internal status signal called FsDetect[1:0].

Like with R-Mod, the *Ratio*₀₋₃ parameters stored in the one time programmable memory remain unchanged. The Automatic Ratio Modifier is enabled either by the *AutoRMod* modal parameter or via the M2 pin in conjunction with the appropriate setting of the *M2Config[2:0]* global parameter (see [Section 5.7.2 on page 20](#)).

| FsDetect[1:0] | $f_{\text{SysClk}} / f_{\text{CLK_IN}}$ | Auto R Modifier |
|---------------|--|-----------------|
| 00 | > 224 | 1 |
| 01 | 96 - 224 | 0.5 |
| 10 | < 96 | 0.25 |

Table 3. Automatic Ratio Modifier

It is important to note that Auto R-Mod (if enabled) is applied in addition to any R-Mod already selected by the *RModSel[1:0]* modal parameter and is used to calculate the Effective Ratio (see [Section 5.4.5 on page 16](#)).

Auto R-Mod can be used to generate the appropriate oversampling clock (MCLK) for audio A/D and D/A converters. For example, if the clock applied to CLK_IN is the audio sample rate, Fs (also known as the word, frame or Left/Right clock), and SysClk is 12.288 MHz (REF_CLK = 12.288 MHz with *RefClkDiv[1:0]* set to '10'), FsDetect[1:0] would then reflect the frequency range of the audio sample rate. An R_{UD} of 512 generates the audio oversampling clocks as shown in [Table 4](#).

| FsDetect[1:0] | Inferred Audio Sample Rate when SysClk = 12.288 MHz | Speed Mode (used for audio converters) | Audio Oversampling Clock |
|---------------|---|--|--------------------------|
| 00 | < 54.8 kHz | Single Speed | 512 x |
| 01 | 54.8 kHz to 128 kHz | Double Speed | 256 x |
| 10 | > 128 kHz | Quad Speed | 128 x |

Table 4. Example Audio Oversampling Clock Generation from CLK_IN

| Referenced Control | Parameter Definition |
|--------------------|---|
| Ratio 0-3..... | "Ratio 0 - 3" on page 24 |
| RModSel[1:0] | "R-Mod Selection (RModSel[1:0])" section on page 23 |
| AutoRMod | "Auto R-Modifier Enable (AutoRMod)" on page 24 |
| M2Config[2:0]..... | "M2 Pin Configuration (M2Config[2:0])" on page 26 |

5.4.5 Effective Ratio (R_{EFF})

The Effective Ratio (R_{EFF}) is an internal calculation comprised of R_{UD} and the appropriate modifiers, as previously described. R_{EFF} is calculated as follows:

Frequency Synthesizer (Static Ratio) Mode: $R_{EFF} = R_{UD} \bullet R\text{-Mod}$

Hybrid PLL (Dynamic Ratio) Mode: $R_{EFF} = R_{UD} \bullet R\text{-Mod} \bullet \text{Auto R-Mod}$

To simplify operation the device handles some of the ratio calculation functions automatically (such as when the internal timing reference clock divider is set). For this reason, the Effective Ratio does not need to be altered to account for internal dividers.

Ratio modifiers which would produce an overflow or truncation of R_{EFF} should not be used. In all cases, the maximum and minimum allowable values for R_{EFF} are dictated by the frequency limits for both the input and output clocks as shown in the ["AC Electrical Characteristics" on page 7](#).

Selection of the user defined ratio from the four stored ratios is made by using the M[1:0] pins unless auto clock switching is enabled in which case the *LockClk[1:0]* modal parameter also selects the ratio (see ["Fractional-N Source Selection" on page 16](#)).

| Referenced Control | Parameter Definition |
|--------------------|--|
| M[1:0] pins..... | "M1 and M0 Mode Pin Functionality" on page 20 |
| LockClk[1:0] | "Lock Clock Ratio (LockClk[1:0])" section on page 24 |

5.4.6 Fractional-N Source Selection

To select between the static ratio based Frequency Synthesizer Mode and the dynamic ratio based Hybrid PLL Mode, the source for the fractional-N value for the Frequency Synthesizer must be changed. The Fractional-N value can either be sourced directly from the Effective Ratio (static ratio) or from the output of the Digital PLL (dynamic ratio) (see [Figure 12 on page 18](#)). The setting of this function can be made manual or automatically depending on the presence of CLK_IN.

5.4.6.1 Manual Fractional-N Source Selection for the Frequency Synthesizer

Manual selection of the fractional-N source for the frequency synthesizer can be done in one of two ways. The *FracNSrc* modal parameter can be set to the desired setting for each available configuration mode and then the Fractional N source is selected by the M1 and M0 pins. In order for this manual selection to work, the *LockClk[1:0]* modal parameter (even if unused) must be set to the same value as the modal ratio (Ratio 0 for Mode 0, Ratio 1 for Mode 1, etc.), see [Section 5.4.6.2 on page 17](#). Alternatively, the M2 pin in conjunction with the *M2Config[2:0]* global parameter can be set to control the fractional N source directly and thus override the *FracNSrc* modal parameter (see [Section 5.7.2.5 on page 21](#) for details).

| Referenced Control | Parameter Definition |
|---------------------|---|
| M[1:0] pins | "M1 and M0 Mode Pin Functionality" on page 20 |
| LockClk[1:0] | "Lock Clock Ratio (LockClk[1:0])" section on page 24 |
| FracNSrc | "Fractional-N Source for Frequency Synthesizer (FracNSrc)" section on page 24 |
| M2Config[2:0] | "M2 Pin Configuration (M2Config[2:0])" on page 26 |

5.4.6.2 Automatic Fractional-N Source Selection for the Frequency Synthesizer

Automatic source selection allows for the selection of the frequency synthesizer's fractional-N value to be made dependent on the presence of the CLK_IN signal. When CLK_IN is present the device will use the dynamic ratio generated from the Digital PLL and CLK_IN for Hybrid PLL Mode. When CLK_IN is not present, the device will use RefClk and the static ratio for Frequency Synthesizer Mode. After losing CLK_IN, the CS2000-OTP will wait for 2²³ SysClk cycles before switching to SysClk and re-acquiring lock, during which time the PLL is unlocked.

The modal ratio location (see [Table 1 on page 10](#)) should contain the desired CLK_OUT to RefClk ratio to be used when CLK_IN is not present. The User Defined Ratio pointed to by *LockClk[1:0]* should contain the desired CLK_OUT to CLK_IN ratio to be used when CLK_IN is present. Automatic source selection is enabled when the *LockClk[1:0]* modal parameter is set to a different User Defined Ratio from the modal ratio location.

When automatic source selection is enabled, the *FracNSrc* modal parameter (used for manual clock selection) will be ignored.

The automatic source selection feature can be disabled by setting the *LockClk[1:0]* modal parameter to the modal ratio location. The *FracNSrc* modal parameter must then be used to select the desired clock used for the PLL's frequency reference. The automatic source selection feature can also be disabled by using the M2 pin in conjunction with the *M2Config[2:0]* global parameter.

| Referenced Control | Parameter Definition |
|---------------------|---|
| M[1:0] pins | "M1 and M0 Mode Pin Functionality" on page 20 |
| LockClk[1:0] | "Lock Clock Ratio (LockClk[1:0])" section on page 24 |
| FracNSrc | "Fractional-N Source for Frequency Synthesizer (FracNSrc)" section on page 24 |
| M2Config[2:0] | "M2 Pin Configuration (M2Config[2:0])" on page 26 |

5.4.7 Ratio Configuration Summary

The R_{UD} is the user defined ratio for which up to four different values ($Ratio_{0-3}$) can be stored in the one time programmable memory. The $M[1:0]$ pins or $LockClk[1:0]$ modal parameter then select the user defined ratio to be used (depending on if static or dynamic ratio mode is to be used). The resolution for the R_{UD} is selectable for the dynamic ratio mode. R-Mods can be applied to both modes whereas Auto R-Mod is only available in dynamic mode. The user defined ratio, ratio modifier, and automatic ratio modifier make up the effective ratio R_{EFF} , the final calculation used to determine the output to input clock ratio. The effective ratio is then corrected for the internal dividers. The frequency synthesizer's fractional-N source selection is made between the static ratio (in frequency synthesizer mode) or the dynamic ratio generated from the digital PLL (in Hybrid PLL mode) by either the $FracNSrc$ modal parameter for manual mode or the presence of CLK_IN in automatic mode. The conceptual diagram in Figure 12 summarizes the features involved in the calculation of the ratio values used to generate the fractional-N value which controls the Frequency Synthesizer. The subscript '4' indicates the modal parameters.

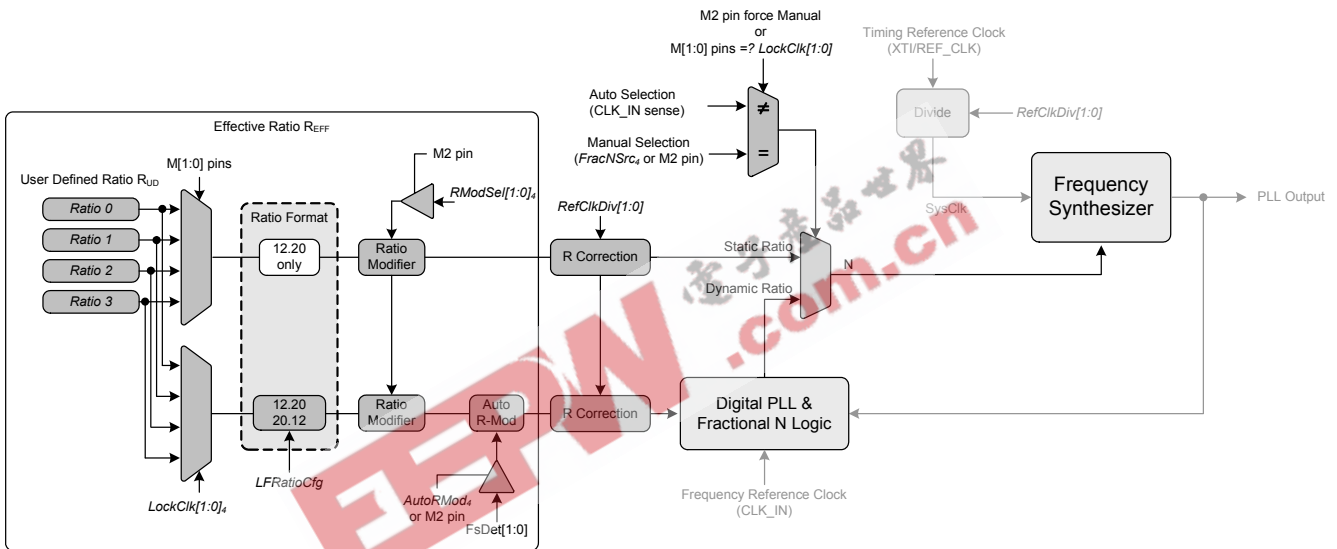

Figure 12. Ratio Feature Summary

| Referenced Control | Parameter Definition |
|------------------------|---|
| Ratio 0-3..... | “Ratio 0 - 3” on page 24 |
| $M[1:0]$ pins..... | “M1 and M0 Mode Pin Functionality” on page 20 |
| $LockClk[1:0]$ | “Lock Clock Ratio ($LockClk[1:0]$)” section on page 24 |
| $LFRatioCfg$ | “Low-Frequency Ratio Configuration ($LFRatioCfg$)” on page 26 |
| $RModSel[1:0]$ | “R-Mod Selection ($RModSel[1:0]$)” section on page 23 |
| $AutoRMod$ | “Auto R-Modifier Enable ($AutoRMod$)” on page 24 |
| $RefClkDiv[1:0]$ | “Reference Clock Input Divider ($RefClkDiv[1:0]$)” on page 25 |
| $FracNSrc$ | “Fractional-N Source for Frequency Synthesizer ($FracNSrc$)” section on page 24 |

5.5 PLL Clock Output

The PLL clock output pin (CLK_OUT) provides a buffered version of the output of the frequency synthesizer. The driver can be set to high-impedance with the M2 pin when the *M2Config[1:0]* global parameter is set to either 000 or 010. The output from the PLL automatically drives a static low condition while the PLL is unlocked (when the clock may be unreliable). This feature can be disabled by setting the *ClkOutUnl* global parameter, however the state CLK_OUT may then be unreliable during an unlock condition.

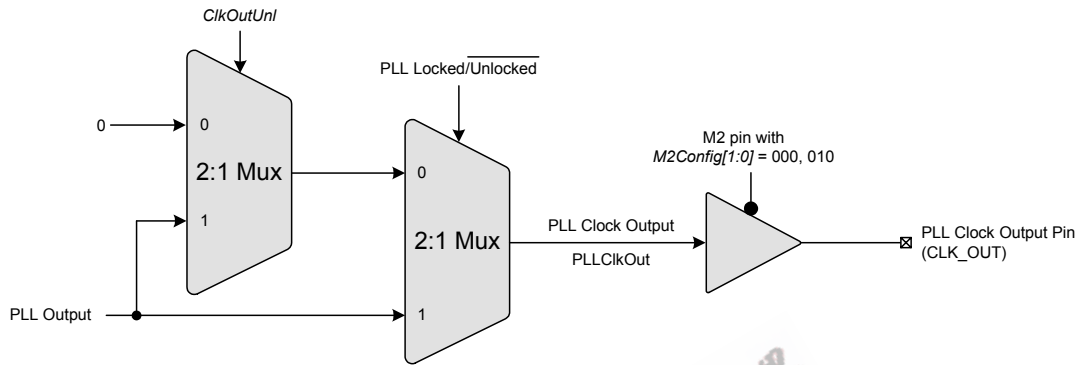

Figure 13. PLL Clock Output Options

| Referenced Control | Parameter Definition |
|--------------------|--|
| ClkOutUnl..... | “Enable PLL Clock Output on Unlock (ClkOutUnl)” on page 25 |
| ClkOutDis..... | “M2 Configured as Output Disable” on page 20 |
| M2Config[2:0]..... | “M2 Pin Configuration (M2Config[2:0])” on page 26 |

5.6 Auxiliary Output

The auxiliary output pin (AUX_OUT) can be mapped, as shown in Figure 14, to one of four signals: reference clock (RefClk), input clock (CLK_IN), additional PLL clock output (CLK_OUT), or a PLL lock indicator (Lock). The mux is controlled via the *AuxOutSrc[1:0]* modal parameter. If AUX_OUT is set to Lock, the *AuxLockCfg* global parameter is then used to control the output driver type and polarity of the LOCK signal (see section 6.3.2 on page 25). If AUX_OUT is set to CLK_OUT, the phase of the PLL Clock Output signal on AUX_OUT may differ from the CLK_OUT pin. The driver for the pin can be set to high-impedance using the M2 pin when the *M2Config[1:0]* global parameter is set to either 001 or 010.

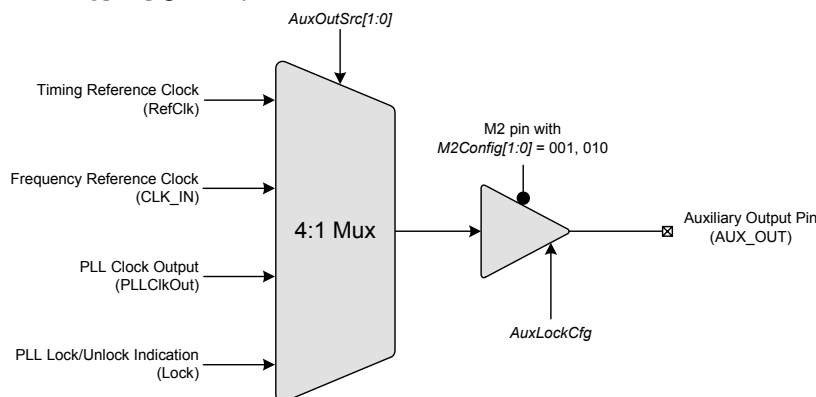

Figure 14. Auxiliary Output Selection

| Referenced Control | Parameter Definition |
|---------------------|---|
| AuxOutSrc[1:0]..... | “Auxiliary Output Source Selection (AuxOutSrc[1:0])” on page 24 |
| AuxOutDis..... | “M2 Configured as Output Disable” on page 20 |
| AuxLockCfg..... | “AUX PLL Lock Output Configuration (AuxLockCfg)” section on page 25 |
| M2Config[2:0]..... | “M2 Pin Configuration (M2Config[2:0])” on page 26 |

5.7 Mode Pin Functionality

5.7.1 M1 and M0 Mode Pin Functionality

M[1:0] determine the functional mode of the device and select both the default User Defined Ratio and the set of modal parameters. The modal parameters are *RModSel[1:0]*, *AuxOutSrc[1:0]*, *AutoRMod*, *LockClk[1:0]*, and *FracNSrc*. By modifying one or more of the modal parameters between the 4 sets, different functional configurations can be achieved. However, global parameters are fixed and the same value will be applied to each functional configuration. Figure 16 on page 23 provides a summary of all parameters used by the device.

5.7.2 M2 Mode Pin Functionality

M2 usage is mapped to one of the optional special functions via the *M2Config[2:0]* global parameter. Depending on what M2 is mapped to, it will either act as an output enable/disable pin or override certain modal parameters. Figure 15 summarizes the available options and the following sections will describe each option in more detail.

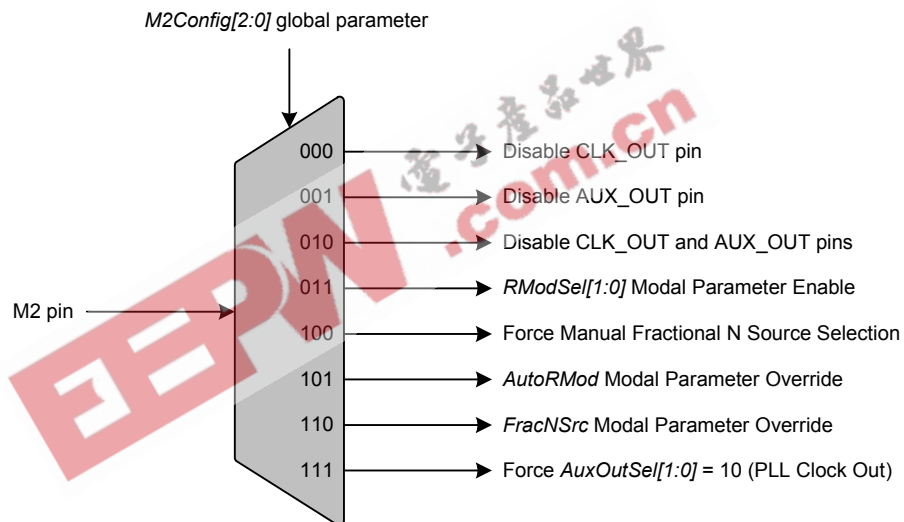

Figure 15. M2 Mapping Options

5.7.2.1 M2 Configured as Output Disable

If *M2Config[2:0]* is set to either '000', '001', or '010', M2 becomes an output disable pin for one or both output pins. If M2 is driven 'low', the corresponding output(s) will be enabled, if M2 is driven 'high', the corresponding output(s) will be disabled.

5.7.2.2 M2 Configured as R-Mod Enable

If *M2Config[2:0]* is set to '011', M2 becomes the R-Mod enable pin. It should be noted that M2 is the only way to enable R-Mod. Even though the *RModSel[1:0]* modal parameter can be set arbitrarily for each configuration set, it will not take effect unless enabled via M2. If M2 is driven 'low', R-Mod will be disabled, if M2 is driven 'high' R-Mod will be enabled.

5.7.2.3 M2 Configured as Auto Fractional-N Source Selection Disable

If *M2Config[2:0]* is set to '100', M2 becomes a disable pin for the auto fractional-N source selection functionality. If auto fractional-N source selection is enabled (see [section 5.4.6 on page 16](#)), driving M2 'high' will disable the auto fractional-N source selection and revert control over the fractional-N source to the *FracNSrc* modal parameter, regardless of the *LockClk[1:0]* modal parameter and the presence of a clock on CLK_IN. If auto fractional-N source selection is not enabled, toggling M2 will have no effect in this case.

5.7.2.4 M2 Configured as Auto R-Mod Enable

If *M2Config[2:0]* is set to '101', M2 becomes the Auto R-Mod enable pin and will override the *AutoRMod* modal parameter. If M2 is driven 'low', Auto R-Mod will be disabled, if M2 is driven 'high' Auto R-Mod will be enabled.

5.7.2.5 M2 Configured as Fractional-N Source Select

If *M2Config[2:0]* is set to '110', M2 becomes the Fractional-N Source Select pin and will override the *FracNSrc* modal parameter. It should be noted that overriding *FracNSrc* has no effect when auto clock switching is enabled (see [section 5.4.6 on page 16](#)). If M2 is driven 'low', the fractional-N value will be the Static Ratio sourced directly from R_{EFF} for Frequency Synthesizer Mode. If M2 is driven 'high' the fractional-N value will be the Dynamic Ratio sourced from the Digital PLL for Hybrid PLL Mode.

5.7.2.6 M2 Configured as AuxOutSrc Override

If *M2Config[2:0]* is set to '111', M2 when driven 'high' will override the *AuxOutSrc[1:0]* modal parameter and force the AUX_OUT source to PLL Clock Output. When M2 is driven 'low', AUX_OUT will function according to *AuxOutSrc[1:0]*.

5.8 Clock Output Stability Considerations

5.8.1 Output Switching

The CS2000-OTP is designed such that re-configuration of the clock routing functions do not result in a partial clock period on any of the active outputs (CLK_OUT and/or AUX_OUT). In particular, enabling or disabling an output, changing the auxiliary output source between REF_CLK and CLK_OUT, changing between Frequency Synthesizer and Hybrid PLL Mode, and the automatic disabling of the output(s) during unlock will not cause a runt or partial clock period.

The following exceptions/limitations exist:

- Enabling/disabling AUX_OUT when *AuxOutSrc* = 11 (unlock indicator).
- Switching *AuxOutSrc[1:0]* to or from 01 (CLK_IN) and to or from 11 (unlock indicator) (Transitions between *AuxOutSrc[1:0]* = [00,10] will not produce a glitch).

When any of these exceptions occur, a partial clock period on the output may result.

5.8.2 PLL Unlock Conditions

Certain changes to the clock inputs and mode pins can cause the PLL to lose lock which will affect the presence of a clock signal on CLK_OUT. The following outlines which conditions cause the PLL to go unlocked:

- Any change in the state of the M1 and M0 pins will cause the PLL to temporarily lose lock as the new setting takes affect.
- Changes made to the state of the M2 when the M2Config[2:0] global parameter is set to 011, 100, 101, or 110 can cause the PLL to temporarily lose lock as the new setting takes affect.
- Any discontinuities on the Timing Reference Clock, REF_CLK.
- Discontinuities on the Frequency Reference Clock, CLK_IN, except when the Clock Skipping feature is enabled and the requirements of Clock Skipping are satisfied (see “CLK_IN Skipping Mode” on page 11).
- Gradual changes in CLK_IN frequency greater than $\pm 30\%$ from the starting frequency.
- Step changes in CLK_IN frequency.

EEPW 电子產品世界
.com.cn

6. PARAMETER DESCRIPTIONS

As mentioned in [Section 5.1 on page 10](#), there are two different kinds of parameter configuration sets, Modal and Global. These configuration sets, shown in [Figure 16](#), can be programmed in the field using the CDK2000 or pre-programmed at the factory. Please see [“Programming Information” on page 28](#) for more details.

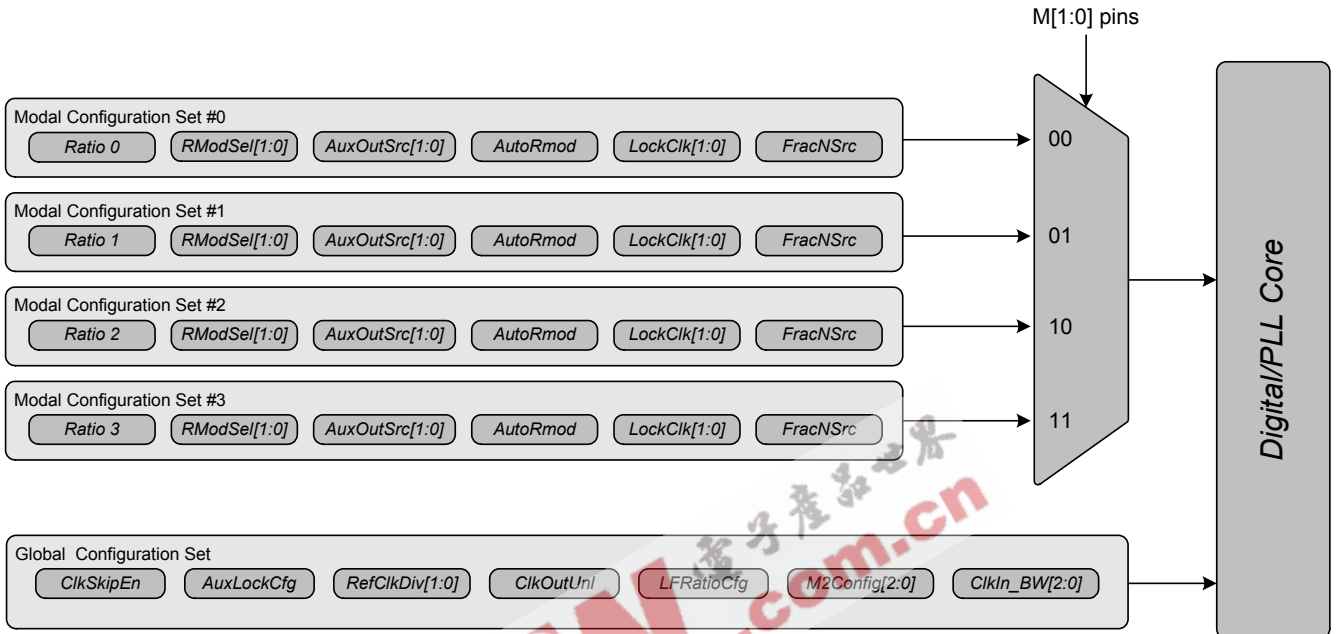

Figure 16. Parameter Configuration Sets

6.1 Modal Configuration Sets

There are four instances of each of these configuration parameters. Selection between the four stored sets is made using the M[1:0] pins.

6.1.1 R-Mod Selection (RModSel[1:0])

Selects the R-Mod value, which is used as a factor in determining the PLL’s Fractional N.

| RModSel[1:0] | R-Mod Selection |
|---------------------|--|
| 00 | Right-shift R-value by 1 ($\div 2$). |
| 01 | Right-shift R-value by 2 ($\div 4$). |
| 10 | Right-shift R-value by 3 ($\div 8$). |
| 11 | Right-shift R-value by 4 ($\div 16$). |
| Application: | “Manual Ratio Modifier (R-Mod)” on page 15 |

Note: This parameter does not take affect unless M2 pin is high and the *M2Config[2:0]* global parameter is set to ‘011’.

6.1.2 Auxiliary Output Source Selection (*AuxOutSrc[1:0]*)

Selects the source of the AUX_OUT signal.

| AuxOutSrc[1:0] | Auxiliary Output Source |
|---------------------|---|
| 00 | RefClk. |
| 01 | CLK_IN. |
| 10 | CLK_OUT. |
| 11 | PLL Lock Status Indicator. |
| Application: | "Auxiliary Output" on page 19 |

Note: When set to 11, the *AuxLockCfg* global parameter sets the polarity and driver type (["AUX PLL Lock Output Configuration \(AuxLockCfg\)" on page 25](#)).

6.1.3 Auto R-Modifier Enable (*AutoRMod*)

Controls the automatic ratio modifier function.

| AutoRMod | Automatic R-Mod State |
|---------------------|---|
| 0 | Disabled. |
| 1 | Enabled. |
| Application: | "Automatic Ratio Modifier (Auto R-Mod) - Hybrid PLL Mode Only" on page 15 |

6.1.4 Lock Clock Ratio (*LockClk[1:0]*)

Selects one of the four stored User Defined Ratios for use in the dynamic ratio based Hybrid PLL Mode.

| LockClk[1:0] | CLK_IN Ratio Selection |
|---------------------|--|
| 00 | Ratio 0. |
| 01 | Ratio 1. |
| 10 | Ratio 2. |
| 11 | Ratio 3. |
| Application: | Section 5.4.2 on page 14 |

Note: The User Defined Ratio for the static ratio based Frequency Synthesizer mode is the ratio that corresponds with the currently chosen configuration set as shown in [Figure 16 on page 23](#).

6.1.5 Fractional-N Source for Frequency Synthesizer (*FracNSrc*)

Selects static or dynamic ratio mode when auto clock switching is disabled.

| FracNSrc | Fractional-N Source Selection |
|---------------------|---|
| 0 | Static Ratio directly from R_{EFF} for Frequency Synthesizer Mode |
| 1 | Dynamic Ratio from Digital PLL for Hybrid PLL Mode |
| Application: | "Fractional-N Source Selection" on page 16 |

6.2 Ratio 0 - 3

The four 32-bit User Defined Ratios are stored in the CS2000's one time programmable memory. See ["Output to Input Frequency Ratio Configuration" on page 14](#) and ["Calculating the User Defined Ratio" on page 27](#) for more details.

6.3 Global Configuration Parameters

6.3.1 Clock Skip Enable (*ClkSkipEn*)

This parameter enables clock skipping mode for the PLL and allows the PLL to maintain lock even when the CLK_IN has missing pulses.

| ClkSkipEn | PLL Clock Skipping Mode |
|---------------------|---|
| 0 | Disabled. |
| 1 | Enabled. |
| Application: | "CLK_IN Skipping Mode" on page 11 |

Note: f_{CLK_IN} must be < 80 kHz to use this feature.

6.3.2 AUX PLL Lock Output Configuration (*AuxLockCfg*)

When the AUX_OUT pin is configured as a lock indicator (*AuxOutSrc[1:0]* modal parameter = '11'), this global parameter configures the AUX_OUT driver to either push-pull or open drain. It also determines the polarity of the lock signal. If AUX_OUT is configured as a clock output, the state of this parameter is disregarded.

| AuxLockCfg | AUX_OUT Driver Configuration |
|---------------------|--|
| 0 | Push-Pull, Active High (output 'high' for unlocked condition, 'low' for locked condition). |
| 1 | Open Drain, Active Low (output 'low' for unlocked condition, high-Z for locked condition). |
| Application: | "Auxiliary Output" on page 19 |

Note: AUX_OUT is an **unlock** indicator, signalling an error condition when the PLL is unlocked. Therefore, the pin polarity is defined relative to the **unlock** condition.

6.3.3 Reference Clock Input Divider (*RefClkDiv[1:0]*)

Selects the input divider for the timing reference clock.

| RefClkDiv[1:0] | Reference Clock Input Divider | REF_CLK Frequency Range |
|---------------------|--|------------------------------------|
| 00 | ÷ 4. | 32 MHz to 75 MHz (50 MHz with XT1) |
| 01 | ÷ 2. | 16 MHz to 37.5 MHz |
| 10 | ÷ 1. | 8 MHz to 18.75 MHz |
| 11 | Reserved. | |
| Application: | "Internal Timing Reference Clock Divider" on page 10 | |

6.3.4 Enable PLL Clock Output on Unlock (*ClkOutUnl*)

Defines the state of the PLL output during the PLL unlock condition.

| ClkOutUnl | Clock Output Enable Status |
|---------------------|--|
| 0 | Clock outputs are driven 'low' when PLL is unlocked. |
| 1 | Clock outputs are always enabled (results in unpredictable output when PLL is unlocked). |
| Application: | "PLL Clock Output" on page 19 |

6.3.5 Low-Frequency Ratio Configuration (*LFRatioCfg*)

Determines how to interpret the currently indexed 32-bit User Defined Ratio when the dynamic ratio based Hybrid PLL Mode is selected (either manually or automatically, see [section 5.4.6 on page 16](#)).

| <i>LFRatioCfg</i> | Ratio Bit Encoding Interpretation when Input Clock Source is CLK_IN |
|---------------------|---|
| 0 | 20.12 - High Multiplier. |
| 1 | 12.20 - High Accuracy. |
| Application: | "User Defined Ratio (RUD), Frequency Synthesizer Mode" on page 14 |

Note: When the static ratio based Frequency Synthesizer Mode is selected (either manually or automatically), the currently indexed User Defined Ratio will always be interpreted as a 12.20 fixed point value, regardless of how this parameter is set.

6.3.6 M2 Pin Configuration (*M2Config[2:0]*)

Controls which special function is mapped to the M2 pin.

| <i>M2Config[2:0]</i> | M2 pin function |
|----------------------|---|
| 000 | Disable CLK_OUT pin. |
| 001 | Disable AUX_OUT pin. |
| 010 | Disable CLK_OUT and AUX_OUT. |
| 011 | <i>RModSel[1:0]</i> Modal Parameter Enable. |
| 100 | Force Manual Fractional N Source Selection. |
| 101 | <i>AutoRMod</i> Modal Parameter Override. |
| 110 | <i>FracNSrc</i> Modal Parameter Override |
| 111 | Force <i>AuxOutSrc[1:0]</i> = 10 (PLL Clock Out). |
| Application: | "M2 Mode Pin Functionality" on page 20 |

6.3.7 Clock Input Bandwidth (*ClkIn_BW[2:0]*)

Sets the minimum loop bandwidth when locked to CLK_IN.

| <i>ClkIn_BW[2:0]</i> | Minimum Loop Bandwidth |
|----------------------|--|
| 000 | 1 Hz |
| 001 | 2 Hz |
| 010 | 4 Hz |
| 011 | 8 Hz |
| 100 | 16 Hz |
| 101 | 32 Hz |
| 110 | 64 Hz |
| 111 | 128 Hz |
| Application: | "Adjusting the Minimum Loop Bandwidth for CLK_IN" on page 13 |

7. CALCULATING THE USER DEFINED RATIO

Note: The software for use with the evaluation kit has built in tools to aid in calculating and converting the User Defined Ratio. This section is for those who would like to know more about how the User Defined Ratio is calculated and stored.

Most calculators do not interpret the fixed point binary representation which the CS2000-OTP uses to define the output to input clock ratio (see [Section 5.4.1 on page 14](#)); However, with a simple conversion we can use these tools to generate a binary or hex value for $Ratio_{0-3}$ to be stored in one time programmable memory. Please see “[Programming Information](#)” on [page 28](#) for more details on programming.

7.1 High Resolution 12.20 Format

To calculate the User Defined Ratio (R_{UD}) to store in the register(s), divide the desired output clock frequency by the given input clock (CLK_IN or RefClk). Then multiply the desired ratio by the scaling factor of 2^{20} to get the scaled decimal representation; then use the decimal to binary/hex conversion function on a calculator and write to the register. A few examples have been provided in [Table 5](#).

| Desired Output to Input Clock Ratio (output clock/input clock) | Scaled Decimal Representation = (output clock/input clock) • 2^{20} | Hex Representation of Binary R_{UD} |
|---|--|---------------------------------------|
| 12.288 MHz/10 MHz=1.2288 | 1288490 | 00 13 A9 2A |
| 11.2896 MHz/44.1 kHz=256 | 268435456 | 10 00 00 00 |

Table 5. Example 12.20 R-Values

7.2 High Multiplication 20.12 Format

To calculate the User Defined Ratio (R_{UD}) to store in the register(s), divide the desired output clock frequency by the given input clock (CLK_IN). Then multiply the desired ratio by the scaling factor of 2^{12} to get the scaled decimal representation; then use the decimal to binary/hex conversion function on a calculator and write to the register. A few examples have been provided in [Table 6](#).

| Desired Output to Input Clock Ratio (output clock/input clock) | Scaled Decimal Representation = (output clock/input clock) • 2^{12} | Hex Representation of Binary R_{UD} |
|---|--|---------------------------------------|
| 12.288 MHz/60 Hz=204,800 | 838860800 | 32 00 00 00 |
| 11.2896 MHz/59.97 Hz =188254.127... | 771088904 | 2D F5 E2 08 |

Table 6. Example 20.12 R-Values

8. PROGRAMMING INFORMATION

Field programming of the CS2000-OTP is achieved using the hardware and software tools included with the CDK2000. The software tools can be downloaded from www.cirrus.com for evaluation prior to ordering a CDK. The CDK2000 is designed with built-in features to ease the process of programming small quantities of devices for prototype and small production builds. In addition to its field programming capabilities, the CDK2000 can also be used for the complete evaluation of programmed CS2000-OTP devices.

The CS2000-OTP can also be factory programmed for large quantity orders. When ordering factory programmed devices, the CDK should first be used to program and evaluate the desired configuration. When evaluation is complete, the CS2000 Configuration Wizard is used to generate a file containing all device configuration information; this file is conveyed to Cirrus Logic as a complete specification for the factory programming configuration. Please contact your local Cirrus Logic sales representative for more information regarding factory programmed parts.

See the CDK2000 datasheet, available at www.cirrus.com, for detailed information on the use of the CDK2000 programming and evaluation tools.

Below is a form which represents the information required for programming a device (noted in gray). The “[Parameter Descriptions](#)” section beginning on page 23 describes the functions of each parameter. This form may be used either for personal notation for device configuration or it can be filled out and given to a Cirrus representative in conjunction with the programming file from the CDK2000 as an additional check. The User Defined Ratio may be filled out in decimal or it may be entered as hex as outlined in “[Calculating the User Defined Ratio](#)” on page 27. For all other parameters mark a ‘0’ or ‘1’ below the parameter name.

| OTP Modal and Global Configuration Parameters Form | | | | | | | | |
|---|---------------------------|------------|------------|------------|------------|----------|----------|----------|
| Modal Configuration Set #0 | | | | | | | | |
| Ratio 0 (dec) | | | | | | | | |
| Ratio 0 (hex) | ____ : ____ : ____ : ____ | | | | | | | |
| | RModSel1 | RModSel0 | AuxOutSrc1 | AuxOutSrc0 | AutoRMod | LockClk1 | LockClk0 | FracNSrc |
| | | | | | | | | |
| Modal Configuration Set #1 | | | | | | | | |
| Ratio 0 (dec) | | | | | | | | |
| Ratio 0 (hex) | ____ : ____ : ____ : ____ | | | | | | | |
| | RModSel1 | RModSel0 | AuxOutSrc1 | AuxOutSrc0 | AutoRMod | LockClk1 | LockClk0 | FracNSrc |
| | | | | | | | | |
| Modal Configuration Set #2 | | | | | | | | |
| Ratio 0 (dec) | | | | | | | | |
| Ratio 0 (hex) | ____ : ____ : ____ : ____ | | | | | | | |
| | RModSel1 | RModSel0 | AuxOutSrc1 | AuxOutSrc0 | AutoRMod | LockClk1 | LockClk0 | FracNSrc |
| | | | | | | | | |
| Modal Configuration Set #3 | | | | | | | | |
| Ratio 0 (dec) | | | | | | | | |
| Ratio 0 (hex) | ____ : ____ : ____ : ____ | | | | | | | |
| | RModSel1 | RModSel0 | AuxOutSrc1 | AuxOutSrc0 | AutoRMod | LockClk1 | LockClk0 | FracNSrc |
| | | | | | | | | |
| Global Configuration Set | | | | | | | | |
| ClkSkipEn | AuxLockCfg | RefClkDiv1 | RefClkDiv0 | ClkOutUnl | LFRatioCfg | M2Cfg2 | M2Cfg1 | M2Cfg0 |
| | | | | | | | | |
| ClkIn_BW2 | ClkIn_BW1 | ClkIn_BW0 | | | | | | |
| | | | | | | | | |

9. PACKAGE DIMENSIONS

10L MSOP (3 mm BODY) PACKAGE DRAWING (Note 1)

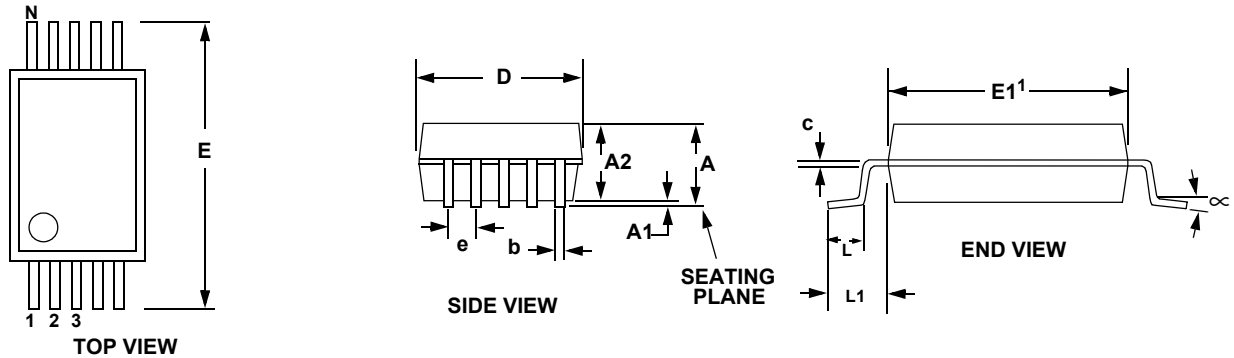

| DIM | INCHES | | | MILLIMETERS | | | NOTE |
|-----|--------|------------|--------|-------------|----------|------|------|
| | MIN | NOM | MAX | MIN | NOM | MAX | |
| A | -- | -- | 0.0433 | -- | -- | 1.10 | |
| A1 | 0 | -- | 0.0059 | 0 | -- | 0.15 | |
| A2 | 0.0295 | -- | 0.0374 | 0.75 | -- | 0.95 | |
| b | 0.0059 | -- | 0.0118 | 0.15 | -- | 0.30 | 4, 5 |
| c | 0.0031 | -- | 0.0091 | 0.08 | -- | 0.23 | |
| D | -- | 0.1181 BSC | -- | -- | 3.00 BSC | -- | 2 |
| E | -- | 0.1929 BSC | -- | -- | 4.90 BSC | -- | |
| E1 | -- | 0.1181 BSC | -- | -- | 3.00 BSC | -- | 3 |
| e | -- | 0.0197 BSC | -- | -- | 0.50 BSC | -- | |
| L | 0.0157 | 0.0236 | 0.0315 | 0.40 | 0.60 | 0.80 | |
| L1 | -- | 0.0374 REF | -- | -- | 0.95 REF | -- | |

Notes: 1. Reference document: JEDEC MO-187

2. D does not include mold flash or protrusions which is 0.15 mm max. per side.
3. E1 does not include inter-lead flash or protrusions which is 0.15 mm max per side.
4. Dimension b does not include a total allowable dambar protrusion of 0.08 mm max.
5. Exceptions to JEDEC dimension.

THERMAL CHARACTERISTICS

| Parameter | | Symbol | Min | Typ | Max | Units |
|---------------------------------------|---------------|---------------|-----|-----|-----|-----------------------------|
| Junction to Ambient Thermal Impedance | JEDEC 2-Layer | θ_{JA} | - | 170 | - | $^{\circ}\text{C}/\text{W}$ |
| | JEDEC 4-Layer | θ_{JA} | - | 100 | - | $^{\circ}\text{C}/\text{W}$ |

10. ORDERING INFORMATION

The CS2000-OTP is ordered as an un-programmed device. The CS2000-OTP can also be factory programmed for large quantity orders. Please see “Programming Information” on page 28 for more details.

| Product | Description | Package | Pb-Free | Grade | Temp Range | Container | Order# |
|------------|---------------------|----------|---------|------------|---------------|---------------|--------------|
| CS2000-OTP | Clocking Device | 10L-MSOP | Yes | Commercial | -10° to +70°C | Rail | CS2000P-CZZ |
| CS2000-OTP | Clocking Device | 10L-MSOP | Yes | | -10° to +70°C | Tape and Reel | CS2000P-CZZR |
| CDK2000 | Evaluation Platform | - | Yes | - | - | - | CDK-2000-CLK |

11. REVISION HISTORY

| Release | Changes |
|---------|---|
| A1 | Initial Release |
| PP1 | Updated “AC Electrical Characteristics” on page 7 |

EEPW.com.cn 电子產品世界

Contacting Cirrus Logic Support

For all product questions and inquiries, contact a Cirrus Logic Sales Representative. To find one nearest you, go to www.cirrus.com.

IMPORTANT NOTICE

“Preliminary” product information describes products that are in production, but for which full characterization data is not yet available.

Cirrus Logic, Inc. and its subsidiaries (“Cirrus”) believe that the information contained in this document is accurate and reliable. However, the information is subject to change without notice and is provided “AS IS” without warranty of any kind (express or implied). Customers are advised to obtain the latest version of relevant information to verify, before placing orders, that information being relied on is current and complete. All products are sold subject to the terms and conditions of sale supplied at the time of order acknowledgment, including those pertaining to warranty, indemnification, and limitation of liability. No responsibility is assumed by Cirrus for the use of this information, including use of this information as the basis for manufacture or sale of any items, or for infringement of patents or other rights of third parties. This document is the property of Cirrus and by furnishing this information, Cirrus grants no license, express or implied under any patents, mask work rights, copyrights, trademarks, trade secrets or other intellectual property rights. Cirrus owns the copyrights associated with the information contained herein and gives consent for copies to be made of the information only for use within your organization with respect to Cirrus integrated circuits or other products of Cirrus. This consent does not extend to other copying such as copying for general distribution, advertising or promotional purposes, or for creating any work for resale.

CERTAIN APPLICATIONS USING SEMICONDUCTOR PRODUCTS MAY INVOLVE POTENTIAL RISKS OF DEATH, PERSONAL INJURY, OR SEVERE PROPERTY OR ENVIRONMENTAL DAMAGE (“CRITICAL APPLICATIONS”). CIRRUS PRODUCTS ARE NOT DESIGNED, AUTHORIZED OR WARRANTED FOR USE IN PRODUCTS SURGICALLY IMPLANTED INTO THE BODY, AUTOMOTIVE SAFETY OR SECURITY DEVICES, LIFE SUPPORT PRODUCTS OR OTHER CRITICAL APPLICATIONS. INCLUSION OF CIRRUS PRODUCTS IN SUCH APPLICATIONS IS UNDERSTOOD TO BE FULLY AT THE CUSTOMER’S RISK AND CIRRUS DISCLAIMS AND MAKES NO WARRANTY, EXPRESS, STATUTORY OR IMPLIED, INCLUDING THE IMPLIED WARRANTIES OF MERCHANTABILITY AND FITNESS FOR PARTICULAR PURPOSE, WITH REGARD TO ANY CIRRUS PRODUCT THAT IS USED IN SUCH A MANNER. IF THE CUSTOMER OR CUSTOMER’S CUSTOMER USES OR PERMITS THE USE OF CIRRUS PRODUCTS IN CRITICAL APPLICATIONS, CUSTOMER AGREES, BY SUCH USE, TO FULLY INDEMNIFY CIRRUS, ITS OFFICERS, DIRECTORS, EMPLOYEES, DISTRIBUTORS AND OTHER AGENTS FROM ANY AND ALL LIABILITY, INCLUDING ATTORNEYS’ FEES AND COSTS, THAT MAY RESULT FROM OR ARISE IN CONNECTION WITH THESE USES.

Cirrus Logic, Cirrus, and the Cirrus Logic logo designs are trademarks of Cirrus Logic, Inc. All other brand and product names in this document may be trademarks or service marks of their respective owners.