



# Automotive Current Mode PWM Control Circuit

## Description

The CS2841B provides all the necessary features to implement off-line fixed frequency current-mode control with a minimum number of external components.

The CS2841B (a variation of the CS-2843A) is designed specifically for use in automotive operation. The low start threshold voltage of 8.0V (typ), and the ability to survive 40V automotive load dump transients are important for automotive subsystem designs. The CS-2841 series has a history of

quality and reliability in automotive applications.

The CS2841B incorporates a precision temperature-controlled oscillator with an internally trimmed discharge current to minimize variations in frequency. Duty-cycles greater than 50% are also possible. On board logic ensures that  $V_{REF}$  is stabilized before the output stage is enabled. Ion implant resistors provide tighter control of under-voltage lockout.

## Features

- Optimized for Off-line Control
- Internally Trimmed Temperature Compensated Oscillator
- Maximum Duty-cycle Clamp
- $V_{REF}$  Stabilized before Output Stage Enabled
- Low Start-up Current
- Pulse-by-pulse Current Limiting
- Improved Undervoltage Lockout
- Double Pulse Suppression
- 1% Trimmed Bandgap Reference
- High Current Totem Pole Output

## Absolute Maximum Ratings

Supply Voltage (Low Impedance Source)	40V
Output Current	$\pm 1A$
Output Energy (Capacitive Load)	5 $\mu J$
Analog Inputs ( $V_{FB}$ , Sense)	-0.3V to 5.5V
Error Amp Output Sink Current	10mA
Lead Temperature Soldering	
Wave Solder (through hole styles only)	10 sec. max, 260°C peak
Reflow (SMD styles only)	60 sec. max above 183°C, 230°C peak

## Block Diagram

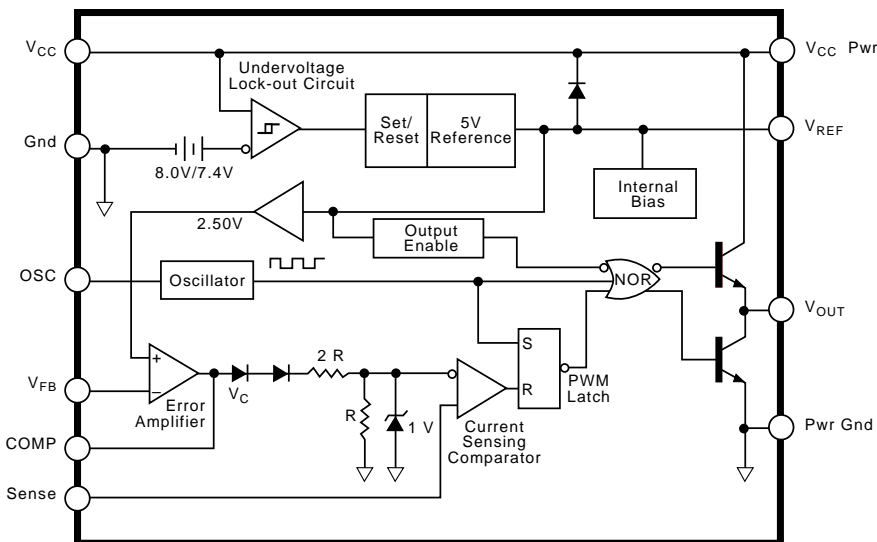

## Package Options

### 8 Lead PDIP

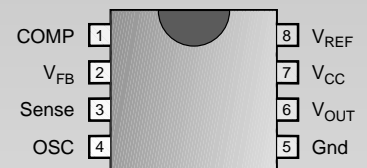

### 14 Lead SO Narrow

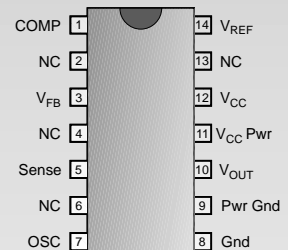

Cherry Semiconductor Corporation  
 2000 South County Trail, East Greenwich, RI 02818  
 Tel: (401)885-3600 Fax: (401)885-5786  
 Email: info@cherry-semi.com  
 Web Site: www.cherry-semi.com

Electrical Characteristics:  $-40 \leq T_A \leq 85^\circ\text{C}$   $R_T=680\text{k}\Omega$ ,  $C_T=0.022\mu\text{F}$  for triangular mode,  $V_{CC}=15\text{V}$  (Note 1),  $R_T=10\text{k}\Omega$ ,  $C_T=3.3\text{nF}$  for sawtooth mode (See Fig. 3), unless otherwise stated.

PARAMETER	TEST CONDITIONS	MIN	TYP	MAX	UNIT
<b>Reference Section</b>					
Output Voltage	$T_J=25^\circ\text{C}$ , $I_{OUT}=1\text{mA}$	4.90	5.00	5.10	V
Line Regulation	$8.4 \leq V_{CC} \leq 16\text{V}$		6	20	mV
Load Regulation	$1 \leq I_{OUT} \leq 20\text{mA}$		6	25	mV
Temperature Stability	(Note 2)		0.2	0.4	mV/ $^\circ\text{C}$
Total Output Variation	Line, Load, Temp. (Note 2)	4.82		5.18	V
Output Noise Voltage	$10\text{Hz} \leq f \leq 10\text{kHz}$ , $T_J=25^\circ\text{C}$ (Note 2)		50		$\mu\text{V}$
Long Term Stability	$T_A=125^\circ\text{C}$ , 1000 Hrs. (Note 2)		5	25	mV
Output Short Circuit	$T_A=25^\circ\text{C}$	-30	-100	-180	mA
<b>Oscillator Section</b>					
Initial Accuracy	Sawtooth Mode: (See Fig. 3) $T_J=25^\circ\text{C}$	47	52	57	kHz
	Sawtooth Mode: $-40^\circ\text{C} \leq T_A \leq +85^\circ$	44	52	60	kHz
	Triangular Mode (See Fig. 3) $T_J=25^\circ\text{C}$	44	52	60	kHz
Voltage Stability	$8.4\text{V} \leq V_{CC} \leq 16\text{V}$		0.2	1.0	%
Temperature Stability	Sawtooth Mode $T_{MIN} \leq T_A \leq T_{MAX}$		5		%
	Triangular Mode $T_{MIN} \leq T_A \leq T_{MAX}$ (Note 2)		8		%
Amplitude	$V_{OSC}$ (peak to peak)		1.7		V
Discharge current	$T_J=25^\circ\text{C}$	7.4	8.3	9.2	mA
	$T_{MIN} \leq T_A \leq T_{MAX}$	7.2		9.4	mA
<b>Error Amp Section</b>					
Input Voltage	$V_{COMP}=2.5\text{V}$	2.42	2.50	2.58	V
Input Bias Current	$V_{FB}=0\text{V}$		-0.3	-2.0	$\mu\text{A}$
$A_{VOL}$	$2 \leq V_{OUT} \leq 4\text{V}$	65	90		dB
Unity Gain Bandwidth	(Note 2)	0.7	1.0		MHz
PSRR	$8.4\text{V} \leq V_{CC} \leq 16\text{V}$	60	70		dB
Output Sink Current	$V_{FB}=2.7\text{V}$ , $V_{COMP}=1.1\text{V}$	2	6		mA
Output Source Current	$V_{FB}=2.3\text{V}$ , $V_{COMP}=5\text{V}$	-0.5	-0.8		mA
$V_{OUT}$ High	$V_{FB}=2.3\text{V}$ , $R_L=15\text{k}\Omega$ to ground	5	6		V
$V_{OUT}$ Low	$V_{FB}=2.7\text{V}$ , $R_L=15\text{k}\Omega$ to $V_{REF}$		0.7	1.1	V
<b>Current Sense Section</b>					
Gain	(Notes 3 & 4)	2.85	3.00	3.15	V/V
Maximum Input Signal	$V_{COMP}=5\text{V}$ (Note 3)	0.9	1.0	1.1	V
PSRR	$12\text{V} \leq V_{CC} \leq 25\text{V}$ (Note 3)		70		dB
Input Bias Current	$V_{Sense}=0\text{V}$		-2	-10	$\mu\text{A}$
Delay to Output	$T_J=25^\circ\text{C}$ (Note 2)		150	300	ns

**Notes:** 1. Adjust  $V_{CC}$  above the start threshold before setting at 15V.  
2. These parameters, although guaranteed, are not 100% tested in production.

3. Parameter measured at trip point of latch with  $V_{FB}=0$ .  
4. Gain defined as:

$$A = \frac{\Delta V_{COMP}}{\Delta V_{Sense}} ; 0 \leq V_{Sense} \leq 0.8\text{V}.$$

## Electrical Characteristics: continued

PARAMETER	TEST CONDITIONS	MIN	TYP	MAX	UNIT
<b>■ Output Section</b>					
Output Low Level	$I_{SINK}=20mA$		0.1	0.4	V
	$I_{SINK}=200mA$		1.5	2.2	V
Output High Level	$I_{SOURCE}=20mA$	13.0	13.5		V
	$I_{SOURCE}=200mA$	12.0	13.5		V
Rise Time	$T_J=25^{\circ}C, C_L=1nF$ (Note 2)		50	150	ns
Fall Time	$T_J=25^{\circ}C, C_L=1nF$ (Note 2)		50	150	ns
Output Leakage	Undervoltage Active, $V_{OUT}=0$		-0.01	-10.00	$\mu A$
<b>■ Total Standby Current</b>					
Start-Up Current			0.5	1.0	mA
Operating Supply Current $I_{CC}$	$V_{FB}=V_{Sense}=0V, R_T=10k\Omega, C_T=3.3nF$		11	17	mA
<b>■ Under-Voltage Lockout Section</b>					
Start Threshold		7.6	8.0	8.4	V
Min. Operating Voltage	After Turn On	7.0	7.4	7.8	V

## Package Pin Description

PACKAGE PIN #		PIN SYMBOL	FUNCTION
8L PDIP	14L SO Narrow		
1	1	COMP	Error amp output, used to compensate error amplifier
2	3	$V_{FB}$	Error amp inverting input
3	5	Sense	Noninverting input to Current Sense Comparator
4	7	OSC	Oscillator timing network with Capacitor to Ground, resistor to $V_{REF}$
5	8	Gnd	Ground
	9	Pwr Gnd	Output driver Ground
6	10	$V_{OUT}$	Output drive pin
	11	$V_{CCPwr}$	Output driver positive supply
7	12	$V_{CC}$	Positive power supply
8	14	$V_{REF}$	Output of 5V internal reference
	2,4,6,13	NC	No Connection

Typical Performance Characteristics:

Oscillator Frequency vs  $C_T$

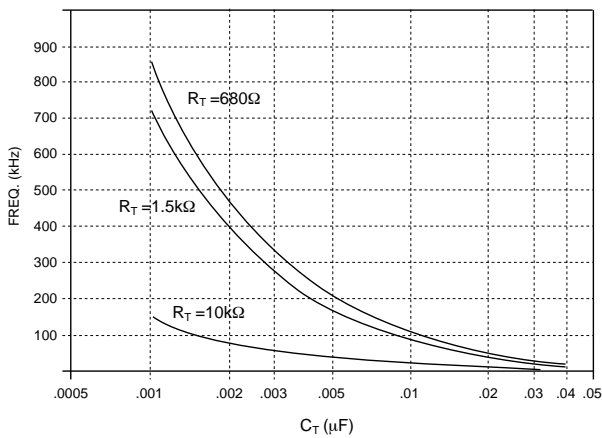

Oscillator Duty Cycle vs  $R_T$

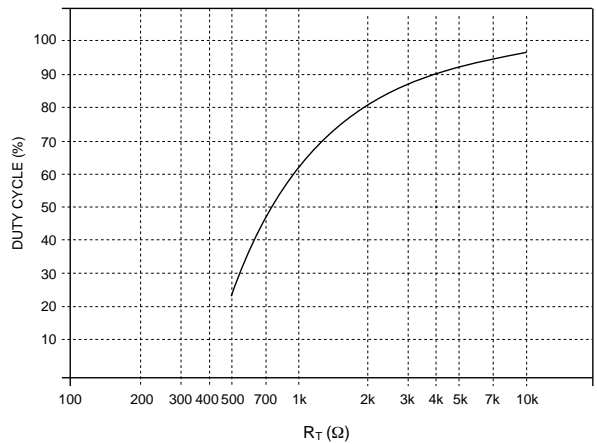

Test Circuit

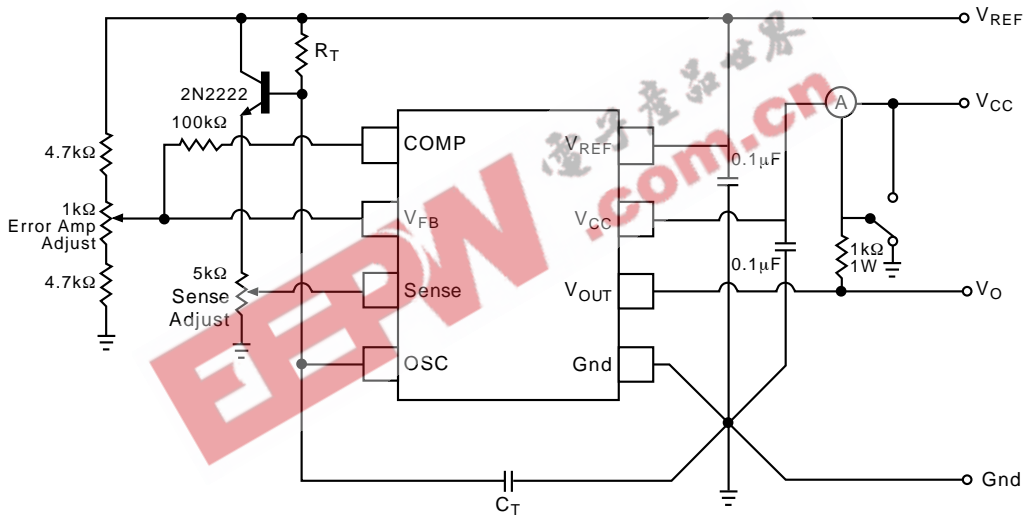

Circuit Description

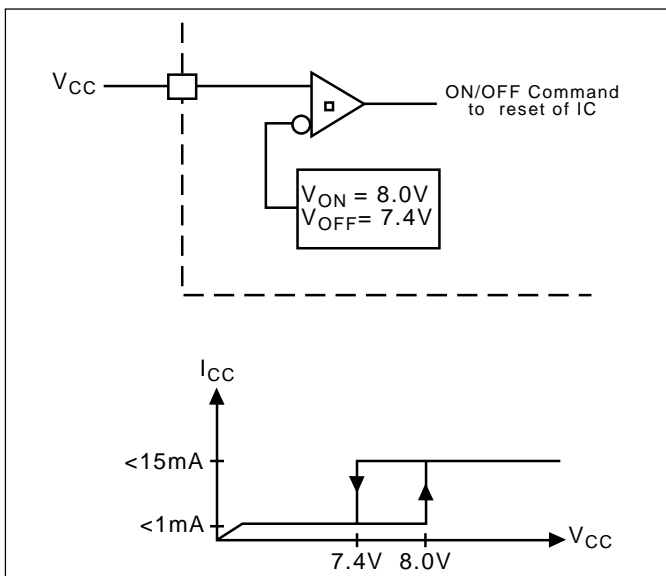

Figure 1: Typical Undervoltage Characteristics

Undervoltage Lockout

During Undervoltage Lockout (Figure 1), the output driver is biased to a high impedance state. The output should be shunted to ground with a resistor to prevent output leakage current from activating the power switch.

PWM Waveform

To generate the PWM waveform, the control voltage from the error amplifier is compared to a current sense signal which represents the peak output inductor current (Figure 2). An increase in  $V_{CC}$  causes the inductor current slope to increase, thus reducing the duty cycle. This is an inherent feed-forward characteristic of current mode control, since the control voltage does not have to change during changes of input supply voltage.

When the power supply sees a sudden large output current increase, the control voltage will increase allowing the duty cycle to momentarily increase. Since the duty cycle tends to exceed the maximum allowed to prevent trans-

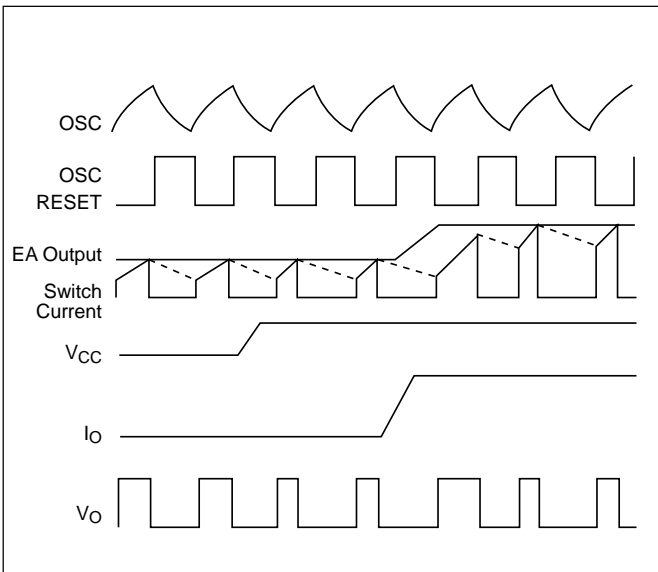

Figure 2: Timing Diagram for key CS2841B parameters

former saturation in some power supplies, the internal oscillator waveform provides the maximum duty cycle clamp as programmed by the selection of OSC components.

### Setting the Oscillator

Oscillator timing capacitor,  $C_T$ , is charged by  $V_{REF}$  through  $R_T$  and discharged by an internal current source. During the discharge time, the internal clock signal blanks out the output to the Low state, thus providing a user selected maximum duty cycle clamp. Charge and discharge times are determined by the general formulas:

$$t_c = R_T C_T \ln \left( \frac{V_{REF} - V_{lower}}{V_{REF} - V_{upper}} \right)$$

$$t_d = R_T C_T \ln \left( \frac{V_{REF} - I_d R_T - V_{lower}}{V_{REF} - I_d R_T - V_{upper}} \right)$$

Substituting in typical values for the parameters in the above formulas:

$$V_{REF} = 5.0V, V_{upper} = 2.7V, V_{lower} = 1.0V, I_d = 8.3mA$$

$$t_c \approx 0.5534 R_T C_T$$

$$t_d = R_T C_T \ln \left( \frac{2.3 - 0.0083 R_T}{4.0 - 0.0083 R_T} \right)$$

The frequency and maximum duty cycle can be determined from the Typical Performance Characteristic graphs.

### Grounding

High peak currents associated with capacitive loads necessitate careful grounding techniques. Timing and bypass capacitors should be connected close to Gnd pin in a single point ground.

The transistor and 5kΩ potentiometer are used to sample the oscillator waveform and apply an adjustable ramp to Sense.

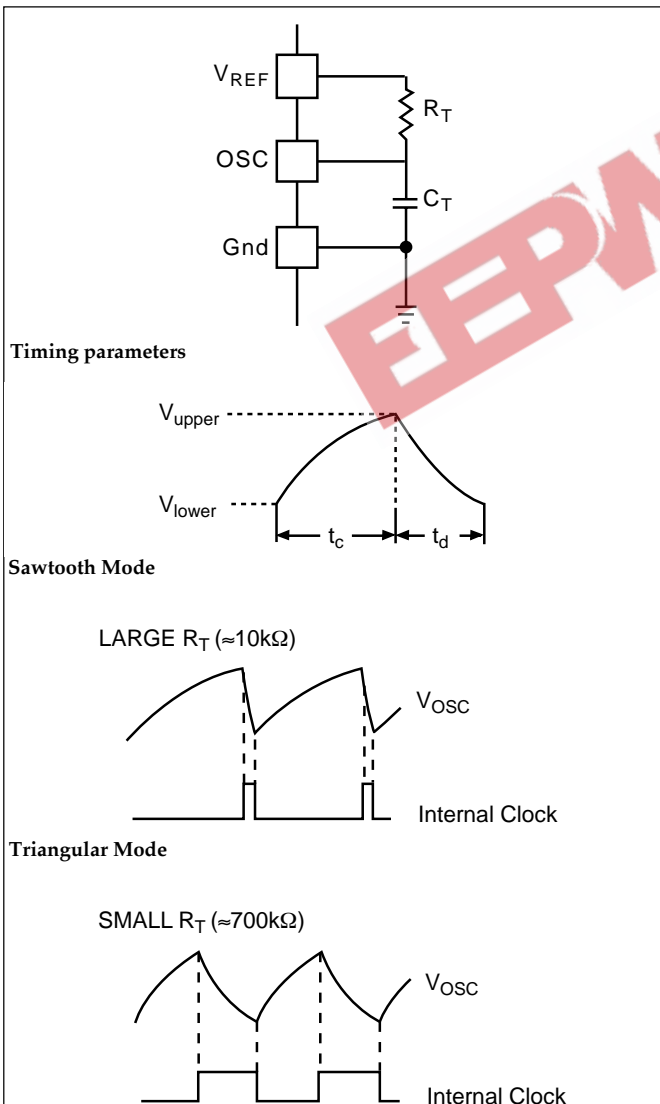

Figure 3: Oscillator Timing Network and parameters

**Package Specification**

**PACKAGE DIMENSIONS IN mm (INCHES)**

Lead Count	D			
	Metric		English	
	Max	Min	Max	Min
8 Lead PDIP	10.16	9.02	.400	.355
14 Lead SO Narrow	8.75	8.55	.344	.337

**PACKAGE THERMAL DATA**

Thermal Data		8 L PDIP	14 L SO Narrow	
$R_{\theta JC}$	typ	52	30	$^{\circ}C/W$
$R_{\theta JA}$	typ	100	125	$^{\circ}C/W$

**Surface Mount Narrow Body (D); 150 mil wide**

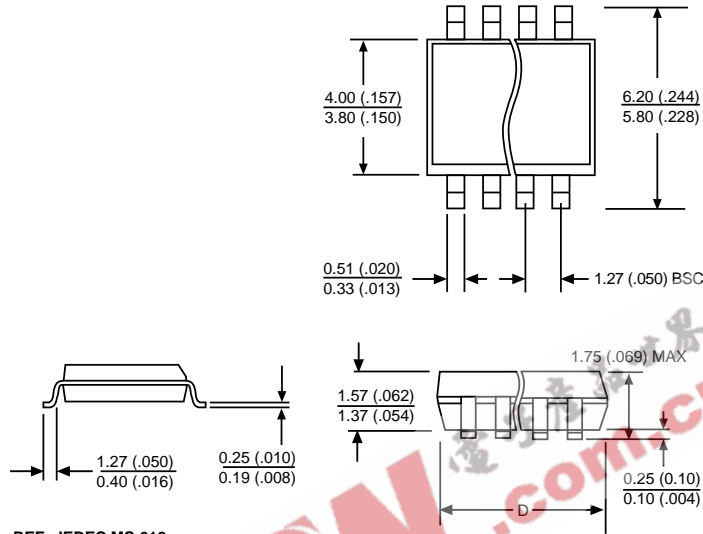

**Plastic DIP (N); 300 mil wide**

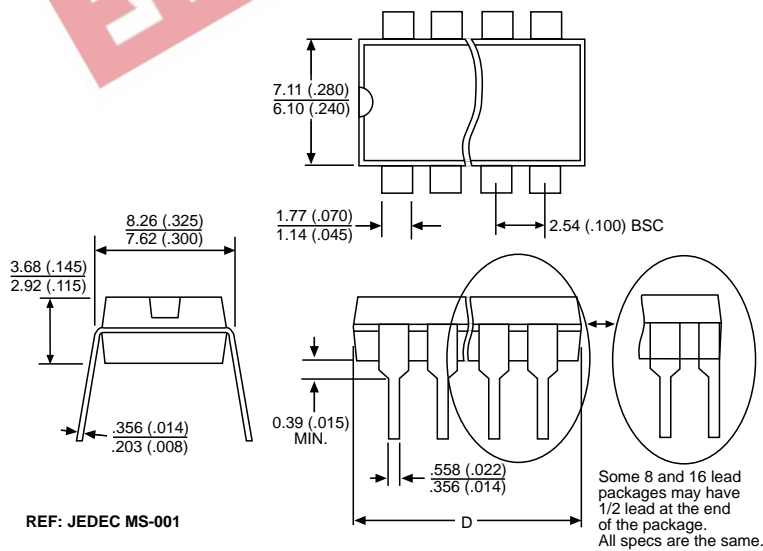

**Ordering Information**

Part Number	Description
CS2841BEN8	8L PDIP
CS2841BED14	14L SO Narrow
CS2841BEDR14	14L SO Narrow (tape & reel)

Cherry Semiconductor Corporation reserves the right to make changes to the specifications without notice. Please contact Cherry Semiconductor Corporation for the latest available information.