



System Photoelectric Smoke Detector

Description

The CS235 System Smoke Detector is a photo electric type with a pulsed infrared LED as the light source and a silicon photodiode as the light detector. The CS235 IC, along with passive external components, controls the system timing and signal processing.

Low average current is attained by pulsing the system once every 10 seconds for 20 milliseconds. Bias is applied to the signal processing circuitry for this time interval. During the second half of the pulse, the last 10 milliseconds, the IR LED is pulsed and the unit samples for an alarm level smoke condition. After the first alarm level signal the sample rate increases to a two second interval. After three consecutive alarm level samples the logic drives the output latch signalling the system panel.

The signal processing circuit blocks

are amplifiers A1 and A2, synchronous detector, voltage comparator and the decode counter. The voltage gain of A2 and the comparator reference voltage are set by external resistors.

Additional on-chip features include an I_{CC} current limiter. The current limiter eliminates power-on false alarming.

The oscillator controls the IR LED excitation frequency and provides drive to the synchronous detector. The synchronous detection method has very high noise rejection performance.

The internal latch is capable of sinking 100 milliamps maximum and will clamp the V_{CC} pin to 5 volts when tripped. The latch current is determined by an external resistor typically located in the master panel and is reset by temporary removal of detector power.

Block Diagram

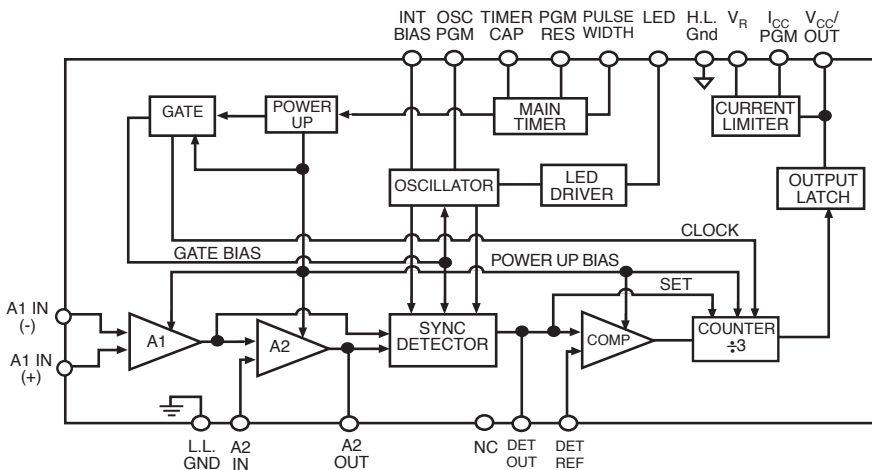

Features

- Synchronous Detection for High Noise Immunity
- Pulsed Operation for Low Average Current Drain
- System Gain Externally Set
- System Sensitivity Externally Adjustable
- System Operation Monitored by Means of External Red LED

Package Options

18 Lead PDIP & SOIC Wide

Timer Pulse Width	1	18	Timer Cap
I_{CC} Program	2	17	Timer Period Program
V_{CC} /Output	3	16	V REG
Hi Level GND	4	15	LED Output
A1 Input (-)	5	14	Oscillator Program
A1 Input (+)	6	13	Internal Bias
LO Level GND	7	12	NC
A2 Input	8	11	Detector Output
A2 Output	9	10	Detector Reference

Absolute Maximum Ratings

Lead Temperature Soldering	
Wave Solder (through hole styles only)	10 sec. max, 260°C peak
Reflow (SMD styles only)	60 sec. max above 183°C, 230°C peak
Storage Temperature Range	-65°C to 150°C

Electrical Characteristics: $T_A = 25^\circ\text{C}$, unless otherwise stated.

PARAMETER	TEST CONDITIONS	MIN	TYP	MAX	UNIT
Absolute Maximum Voltage	(pin 3)			38	V
Output Latch Current				100	mA
Operation Temperature Range, T_A		0		70	°C

■ 24V System ($C_2 = 100\ \mu\text{F}$, $R_7 = 12\ \text{M}\Omega$)

Operating Voltage	(pin 3)	13.8	22.5	35	V
Average Supply Current	V (pin 3) = 22.5V		35	60	μA
Peak Supply Current	V (pin 3) = 22.5V (non "speed up")			100	μA
Peak Supply Current	V (pin 16) = 12V ("speed up")		150	350	μA
Regulator Voltage	(pin 16)	12.8		15.7	V

■ 12V System ($C_2 = 150\ \mu\text{F}$, $R_7 = 12\ \text{M}\Omega$)

Operating Voltage	(pin 3)	8.7	12		V
Average Supply Current	V (pin 3) = 12V			60	μA
Peak Supply Current	V (pin 3) = 12V (non "speed up")			100	μA
Peak Supply Current	V (pin 16) = 8V ("speed up" mode)			350	μA
Regulator Voltage	(pin 16) (V pin 3 = 12V)		11.85		V

■ Oscillator

Output Frequency	$R_6 = 18\text{k}\Omega$, $C_3 = .0068\ \mu\text{F}$	2.1	3.3	4.4	kHz
Sink Current	(pin 14)	16	26	35	μA
Source Current	(pin 14)	19	26	32	μA
High Trip Point Voltage	(pin 14)	1.8	1.9	2.2	V
Low Trip Point Voltage	(pin 14)	1.2	1.4	1.5	V

■ LED Drive (Detector LED and Status LED)

Source Current (pin 15)	$R_8 = 36\ \Omega$				
Detector LED	V IR LED = 1.156V	20	30	40	mA
Status LED (alarm)	V Status LED = 1.99V	10			mA
Regulator Voltage (pin 15)	$I_{\text{SOURCE}} = 30\text{mA}$	3.7	4.4	5.2	V

■ Amplifier A1

Fixed Gain			26		dB
Input Current B_1	(pin 5)		500	1000	nA
Input Current B_2	(pin 6)		500	1000	nA
Input current (B_1 - B_2)				250	nA

Electrical Characteristics: $T_A = 25^\circ\text{C}$

PARAMETER	TEST CONDITIONS	MIN	TYP	MAX	UNIT
■ Amplifier A2					
DC Output (pin 9)	R3 = 6k Ω , R4 = 510 Ω , C5 = .47 μ F		2.5		V
Input Bias Current (pin 8)	(Externally adjusted gain with R3 and R4. Unity DC gain)			250	nA
Voltage gain @ 3.5kHz	(Externally adjusted gain with R3 and R4. Unity DC gain)		21.6		dB
■ Detector and Reference Output (C4 = .47μF)					
Reference Resistance		13	19	25	k Ω
Reference Voltage	(pin 10)	1.8	3.6	5.5	V
Detector Output Resistance		10	15	20	k Ω
Detector Output Voltage	(pin 11) (No signal, and at 2X time Constant)	1.4	2.8	4.3	V
■ Main Timer (R1 = 20MΩ, R2 = 75kΩ, C1 = .47μF)					
Power Up Pulse Period	Standby Mode (pin 1)	8	10	12	Sec
Power Up Pulse Period	Speed Up Mode (pin 1)	1.5	2	2.5	Sec
Power Up Pulse Width	(pin 1)		20		ms
Gate Pulse Width	Power up pulse width 12		10		ms
Sink Current (pin 18)	V (pin 16) = 16V	415	460	505	nA
Source Current (pin 18)	V (pin 16) = 16V	-220	-235	-250	μ A
■ Output Circuit					
Output Latch Voltage	(pin 3) $I_{\text{SUPPLY}} = 100\text{mA}$	4.4	5.2	6.1	V
Leakage Current	V (pin 3) = 38V, V (pins 2, 16) = 0V		500		μ A
■ Alarm					
Alarm Reset	Supply interruption			5	Sec
Power up time				30	Sec
System will go into alarm upon detection and transfer of three consecutive alarm level signals into the counter.					

Timing Diagrams

Timing Diagram Out of Alarm

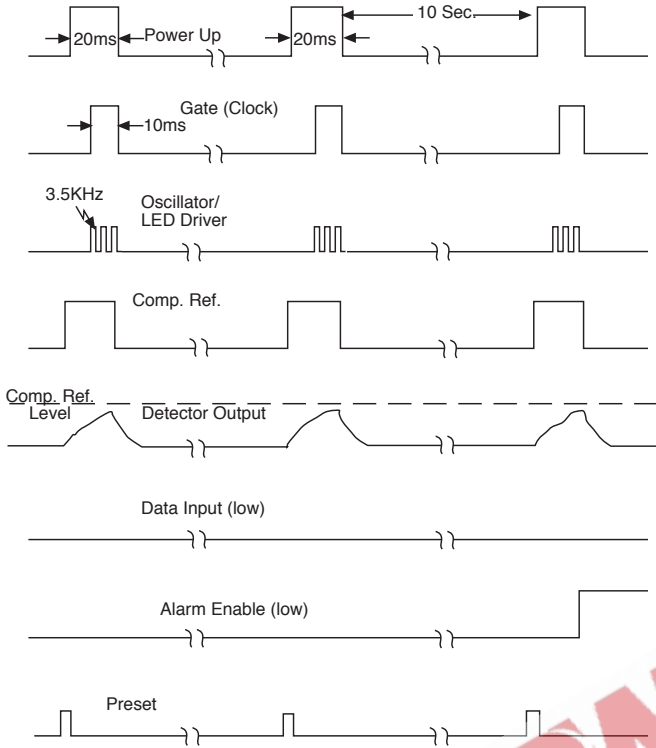

Timing Diagram In Alarm

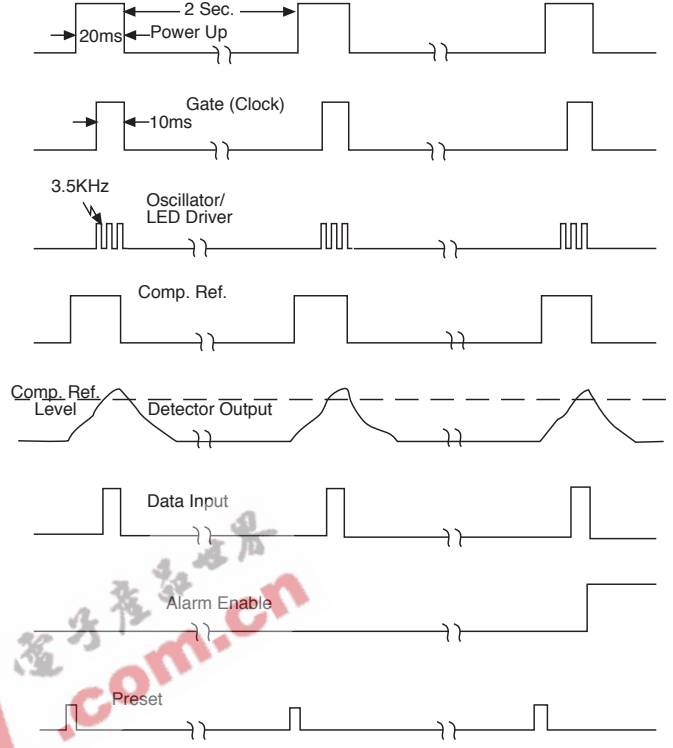

EEPW 电子产业世界 .com.cn

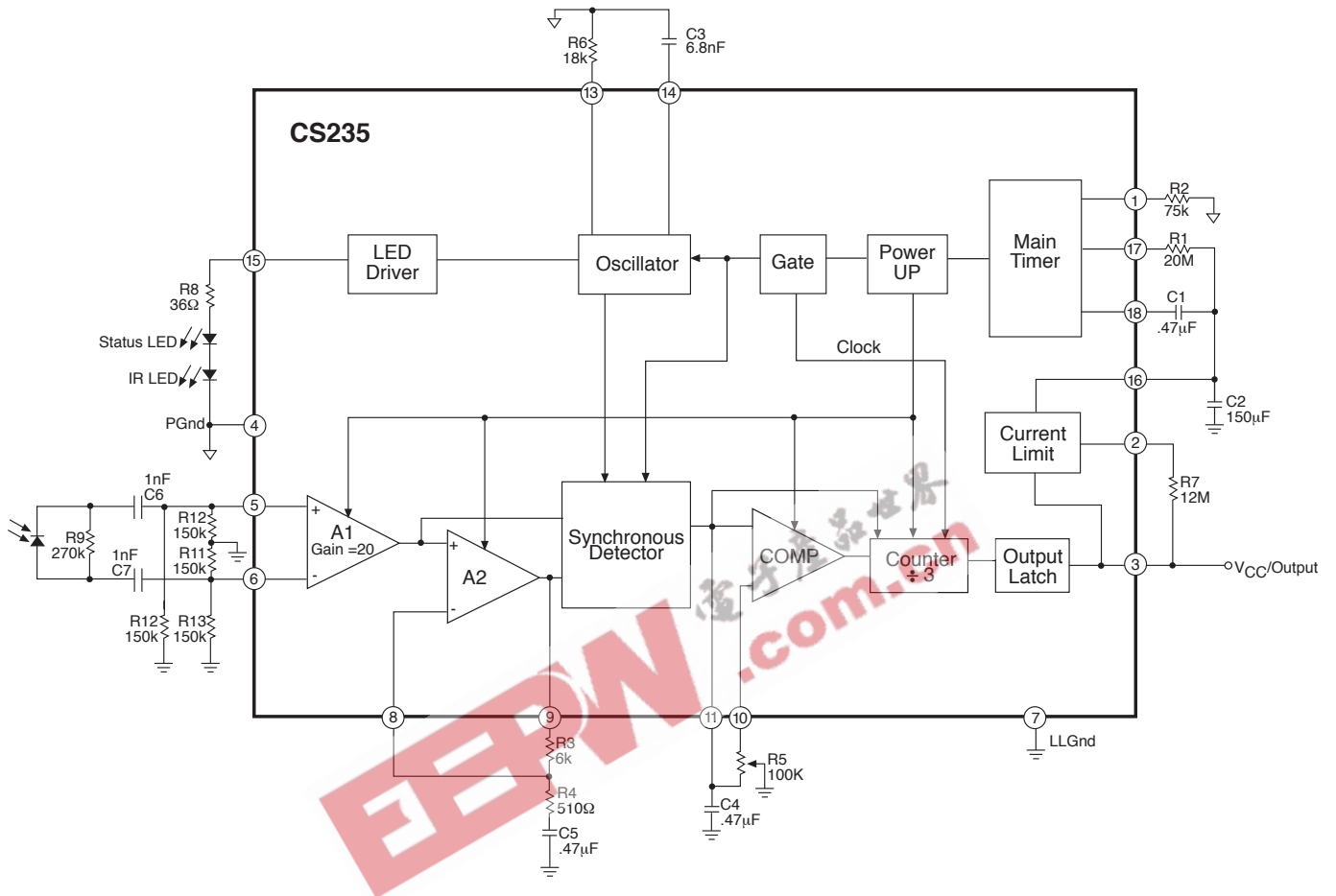

Package Specification

PACKAGE DIMENSIONS IN mm (INCHES)

Lead Count	D			
	Metric		English	
	Max	Min	Max	Min
18L PDIP	23.37	22.35	.920	.880
18L SO Wide	11.75	11.35	.463	.447

PACKAGE THERMAL DATA

Thermal Data		18L SO Wide	18L PDIP	
R _{θJC}	typ	21	29	°C/W
R _{θJA}	typ	100	65	°C/W

Plastic DIP (N); 300 mil wide

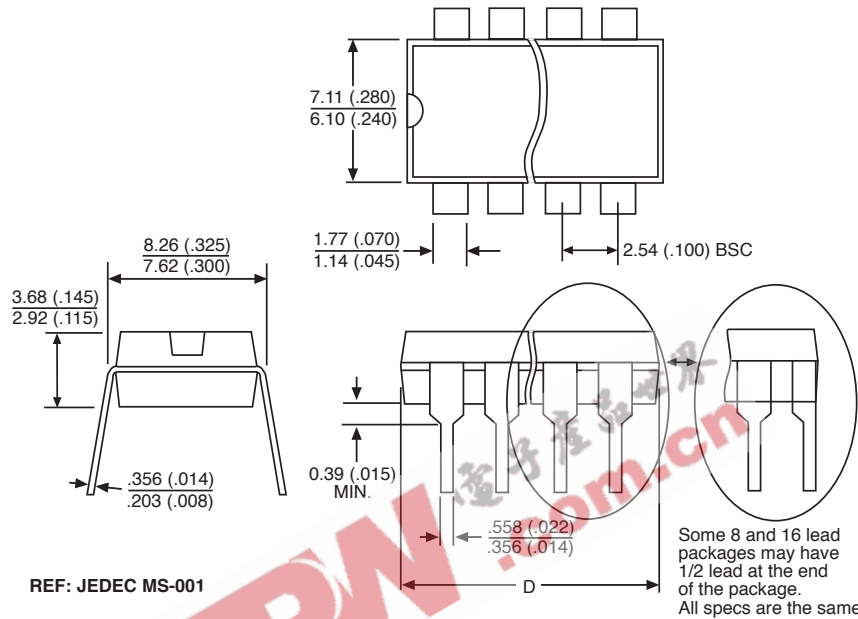

Surface Mount Wide Body (DW); 300 mil wide

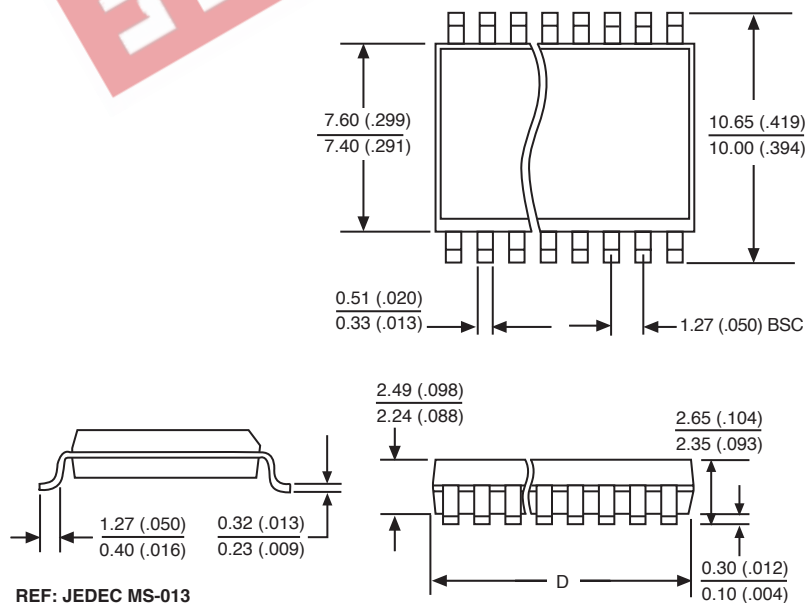

Ordering Information

Part Number	Description
CS235GDW18	18L SO
CS235GDWR18	18L SO (tape & reel)
CS235GN18	18L PDIP

Cherry Semiconductor Corporation reserves the right to make changes to the specifications without notice. Please contact Cherry Semiconductor Corporation for the latest available information.