



20mA Air-Core Tachometer Drive Circuit

Description

The CS289 is specifically designed for use with air-core meter movements. The IC has charge pump circuitry for frequency-to-voltage conversion, a shunt regulator for stable

operation, a function generator, and sine and cosine amplifiers. The buffered sine and cosine outputs will typically sink or source 20mA.

Absolute Maximum Ratings

Supply Voltage (V_{CC}).....	20V
Operating Temperature	-40°C to +100°C
Junction Temperature.....	-40°C to 150°C
Storage Temperature.....	-65°C to +150°C
Lead Temperature Soldering	
Wave Solder (through hole styles only).....	10 sec. max, 260°C peak
Reflow (SMD styles only).....	60 sec. max above 183°C, 230°C peak

Block Diagram

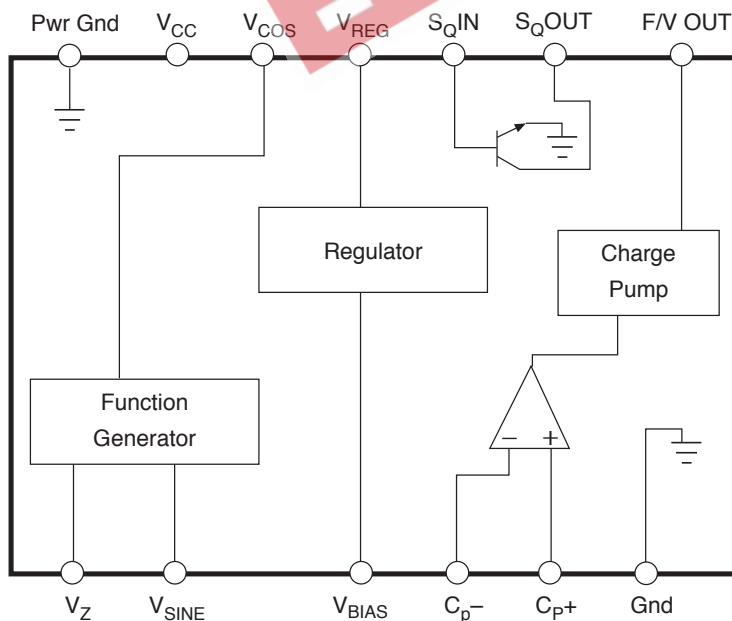

Features

- Single Supply Operation
- On-Chip Regulation
- 20mA Output Drive Capability

Package Options

14L PDIP

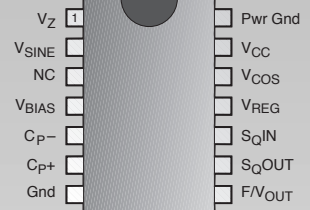

20L SOIC Wide (internally fused leads)

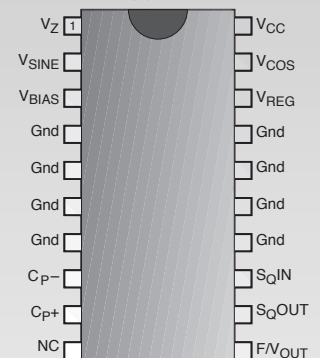

Cherry Semiconductor Corporation
 2000 South County Trail, East Greenwich, RI 02818
 Tel: (401)885-3600 Fax: (401)885-5786
 Email: info@cherry-semi.com
 Web Site: www.cherry-semi.com

Electrical Characteristics: ($V_{CC} = 13.1V$, $-30^{\circ}C \leq T_A \leq 85^{\circ}C$)

PARAMETER	TEST CONDITIONS	MIN	TYP	MAX	UNIT
Supply Current (Note 2)	$V_{CC} = 15.0V$		54		mA
	$V_{CC} = 13.1V$		60	65	mA
	$V_{CC} = 11.3V$		60	65	mA
Regulated Voltage	$I_{REG} = 4.3mA$	7.7	8.5	9.3	V
Regulation	$I_{REG} = 0$ to 5mA		0.10	0.20	V
Signal Input Current	$T = 25^{\circ}C$	0.1	2.0	4.0	mA
Saturation Voltage	$I_{SQ\ OUT} = 5mA$, $I_{SQ\ IN} = 500\mu A$		0.20	0.55	V
Leakage Current	$I_{SQ\ OUT} = 16V$, $V_{SQ\ IN} = 0V$			10	μA
Input Current	$C_{P+} = 0$, $T = 25^{\circ}C$		1	15	nA
F to V Output	$V_{SQ\ IN} = 0$ (zero input), $\phi = 0^{\circ}$	1.8	2.1	2.4	V
	$V_{COS} = 0$ (Note 1), $\phi = 270^{\circ}$	6.3	7.1	7.9	
Linearity	E_O vs. Frequency				
	$V_{COS} = 0$ (Note 1), $\phi = 270^{\circ}$, $T = 25^{\circ}C$	-1.5		1.5	%
V_{sine} at $\phi = 0^{\circ}$	$V_{SQ\ IN} = 0$ (zero input), $\phi = 0^{\circ}$	-0.55	0.00	0.55	V
MAX V_{sine+}	$V_{COS} = 0$ (Note 1), $\phi = 90^{\circ}$	3.8	4.5	5.8	V
MAX V_{sine-}	$V_{COS} = 0$ (Note 1), $\phi = 270^{\circ}$	-3.8	-4.5	-5.8	V
Coil Drive Current	$V_{COS} = 0$ (Note 1), $\phi = 90^{\circ}$, $T = 25^{\circ}C$		20	25	mA
	$V_{COS} = 0$ (Note 1), $\phi = 270^{\circ}$		20	25	mA
MAX V_{COS+}	$V_{SQ\ IN} = 0$ (zero input), $\phi = 0^{\circ}$	3.8	4.5	5.8	V
MAX V_{COS-}	$V_{sine} = 0$ (Note 1), $\phi = 180^{\circ}$	-3.8	-4.5	-5.8	V
Coil Drive Current	$V_{SQ\ IN} = 0$ (zero input), $\phi = 0^{\circ}$		20	25	mA
	$V_{sine} = 0$ (Note 1), $\phi = 180^{\circ}$		20	25	mA
External Voltage Ref.		4.98	5.40	5.85	V

Note 1: V_{sine} measured V_{sine} to V_Z . V_{COS} measured V_{COS} to V_Z . All other voltages specified are measured to ground.

Note 2: Max PWR dissipation $\leq V_{CC} \times I_{CC} - (V_2 I_{sine} + V_{I2} I_{COS})$.

Package Pin Description

PACKAGE PIN #	PIN SYMBOL	FUNCTION
20L SO		
<i>(internally fused leads)</i> 14L PDIP		
1	1	V_Z External Zener reference.
2	2	V_{sine} Sine output signal.
3	4	V_{BIAS} Test pin or "0" calibration pin.
4, 5, 6, 7, 14, 15, 16, 17	7	Gnd Analog Ground connection.
8	5	C_{P-} Negative input to charge pump.
9	6	C_{P+} Positive input to charge pump.
10	3	NC No Connection
11	8	F/ V_{OUT} Output voltage proportional to input signal frequency.

Package Pin Description: continued

PACKAGE PIN #		PIN SYMBOL	FUNCTION
20L SO	14L PDIP		
12	9	S _Q OUT	Buffered square wave output signal.
13	10	S _Q IN	Speed or RPM input signal.
18	11	V _{REG}	Voltage regulator output.
19	12	V _{COS}	Cosine output signal.
20	13	V _{CC}	Supply voltage.
	14	Pwr Gnd	Power Ground connection.

Note 1: V_{sine} measured V_{sine} to V_Z. V_{cos} measured V_{cos} to V_Z. All other voltages specified are measured to ground.

Note 2: Max PWR dissipation $\leq V_{CC} \times I_{CC} - (V_2 I_{sine} + V_{12} I_{cos})$.

Typical Performance Characteristics

Output Angle in Polar Form

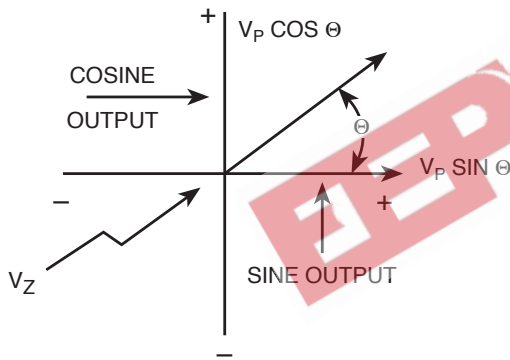

Charge Pump Output Voltage

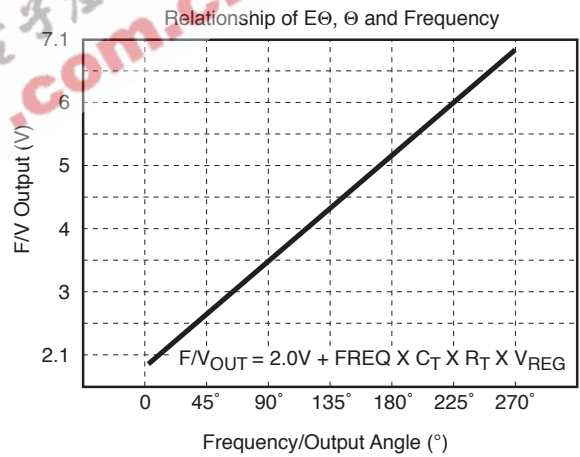

Function Generator Output Voltage

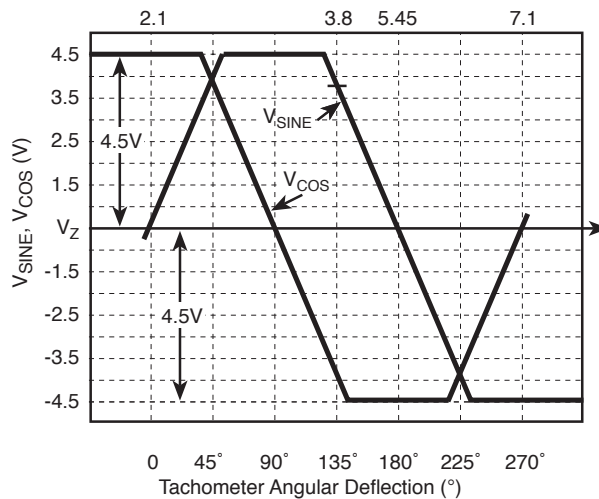

Charge Pump

The input frequency is buffered through a transistor, then applied to the charge pump for frequency-to-voltage conversion (Figure 1). The charge pump output voltage, $E\phi$, will range from 2.1V with no input ($\phi = 0^\circ$) to 7.1V at $\phi = 270^\circ$. The charge that appears on C_T is reflected to C_{OUT} through a Norton amplifier. The frequency applied at S_QIN charges and discharges C_T through R_1 and R_2 . C_{OUT} reflects the charge as a voltage across resistor R_T .

Function Generator/Sine and Cosine Amplifiers

The output waveforms of the sine and cosine amplifiers are derived by On-Chip Amplifier/Comparator circuitry. The various trip points for the circuit (i.e. 90° , 180° , 270°) are determined by an internal resistor divider connected to the voltage regulator. The voltage $E\phi$ is compared to the divider network by the function generator circuitry. Use of an external zener reference at V_Z allows both sine and cosine amplifiers to swing positive and negative with respect to this reference. The output magnitudes and directions have the relationship as shown in Typical Characteristics diagrams.

Note: Pin connections referenced are for the 14L DIP.

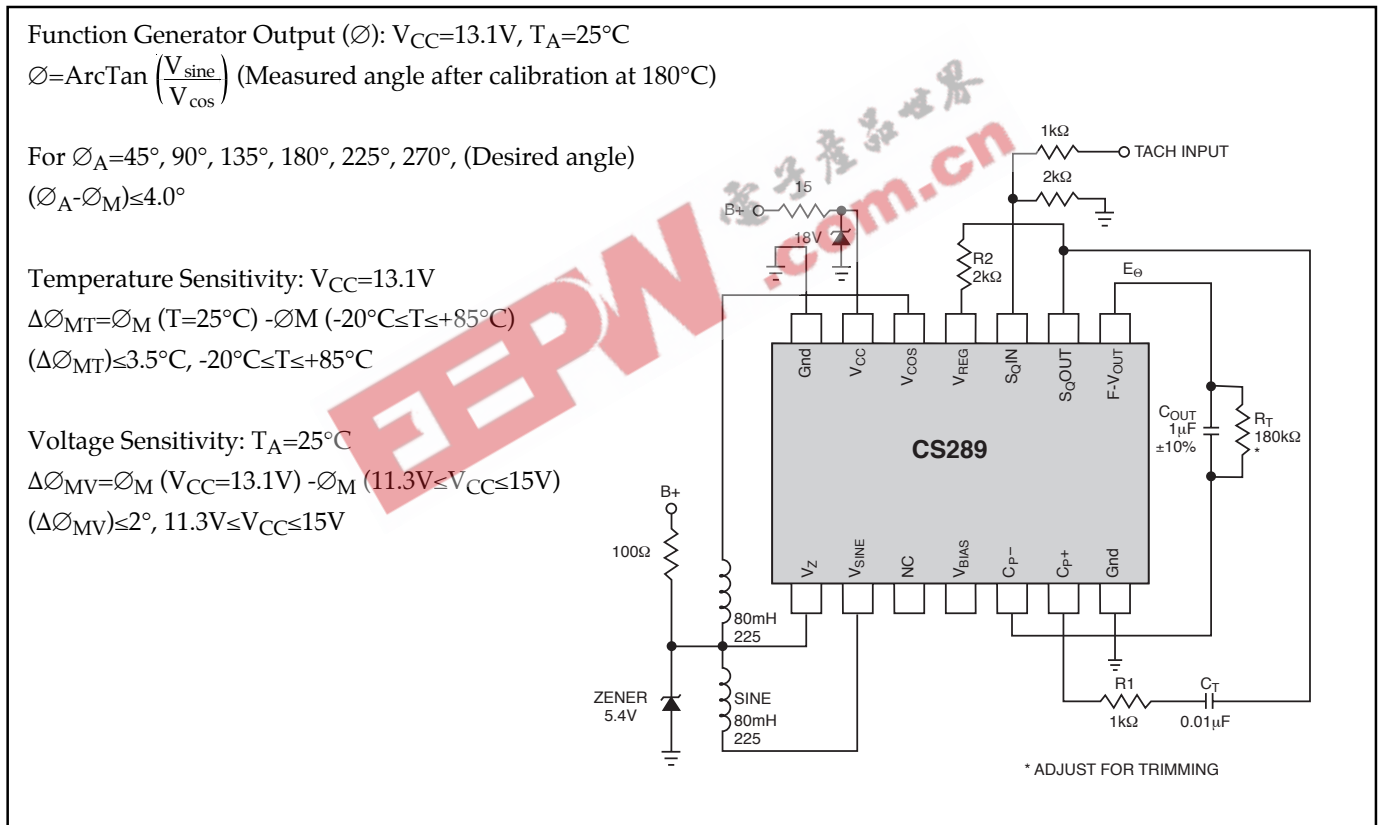

Figure 1. Functional Diagram of CS289 Circuit.

$$\frac{\text{RPM}}{60} \times \frac{\# \text{ OF CYL.}}{2} = \text{Frequency}$$

$$V_{F/V_{OUT}} = 2.1 + \text{Frequency} \times C_T \times R_T (V_{REG} - 0.7)$$

The above equations were used in calculating the following values, where $V_{F/V_{OUT}} = 7.1V$ at $\pm 270^\circ$ and $C_T = 0.01 F$.

- 4 cylinder: Freq = 200Hz, $R_T = 320k\Omega$
- 6 cylinder: Freq = 300Hz, $R_T = 220k\Omega$
- 8 cylinder: Freq = 400Hz, $R_T = 150k\Omega$

Typical values shown above apply to a nominal value of V_{REG} of 8.5 volts. It must be realized that trimming of R_T will be necessary to compensate for variations in regulator voltage from one unit to another.

An alternative to this adjustment is to replace R_2 with a potentiometer, as shown in Figure 2.

Partial schematic shown in Figure 3 represents one method for use with DC applications instead of frequency.

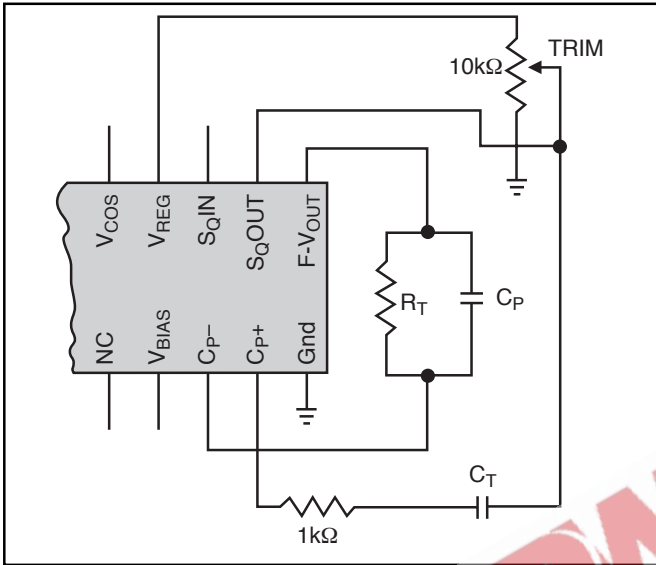

Figure 2: Alternate Trimming Method

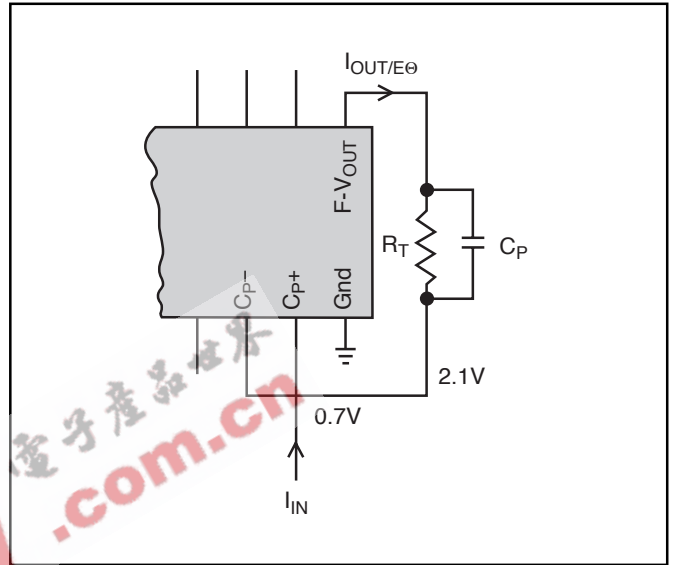

Figure 3: DC Application

EEPW.com.cn

Package Specification

PACKAGE DIMENSIONS IN mm (INCHES)

Lead Count	D			
	Metric		English	
	Max	Min	Max	Min
14L PDIP	19.69	18.67	.775	.735
20L SO Wide <i>(internally fused leads)</i>	13.00	12.60	.512	.496

PACKAGE THERMAL DATA

Thermal Data		14L PDIP Wide	20L SOIC <i>(internally fused leads)</i>	
R _{θJC}	typ	48	17	°C/W
R _{θJA}	typ	85	90	°C/W

Plastic DIP (N); 300 mil wide

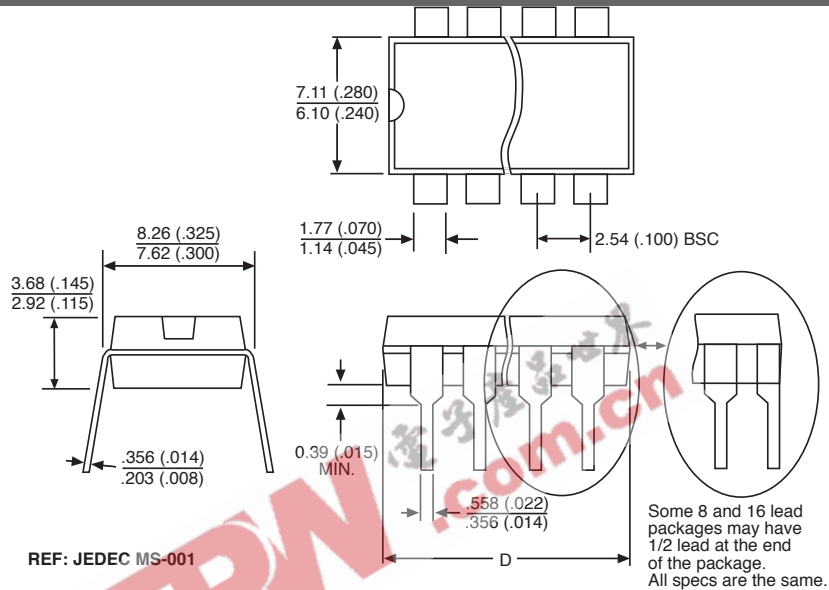

Surface Mount Wide Body (DW); 300 mil wide

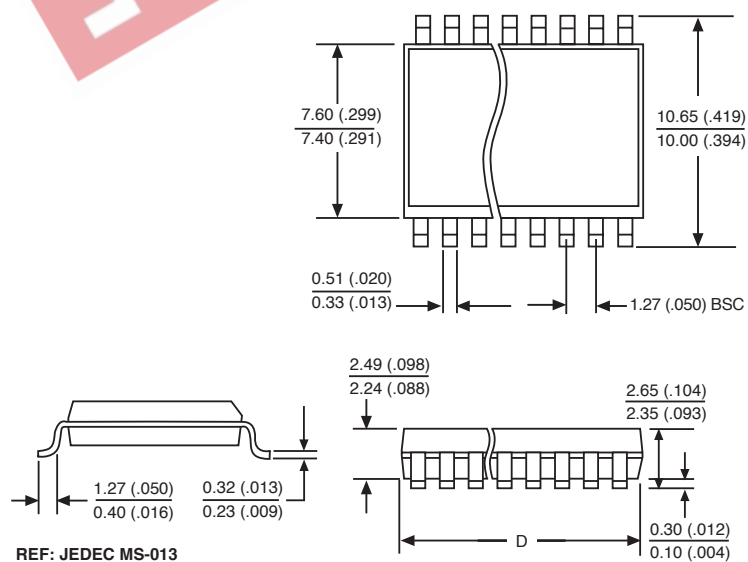

Ordering Information

Part Number	Description
CS289GDWF20	20 Lead SO Wide <i>(internally fused leads)</i>
CS289GDWFR20	20 Lead SO Wide <i>(internally fused leads)</i> <i>(tape & reel)</i>
CS289GN14	14 Lead PDIP

Cherry Semiconductor Corporation reserves the right to make changes to the specifications without notice. Please contact Cherry Semiconductor Corporation for the latest available information.