

## FM/AM Radio

**Description**

CXA1691M/S is a one-chip FM/AM radio IC designed for radio-cassette tape recorders.

**Features**

- Small number of peripheral components.
- Low current consumption ( $V_{CC}=3V$ )
  - FM:  $I_D=5.3mA$  (Typ.)
  - AM:  $I_D=3.4mA$  (Typ.)
- Built-in FM/AM select switch.
- Large output of AF amplifier.
  - $V_{CC}=6V$ , EIAJ output= $500mW$  (Typ.)
  - when load impedance  $8\Omega$

**Functions****FM section**

- RF amplifier, Mixer and OSC (incorporating AFC variable capacitor).
- IF amplifier
- Quadrature detection
- Tuning LED driver

**AM section**

- RF amplifier, Mixer and OSC (with RF AGC)
- IF amplifier (with IF AGC)
- Detector
- Tuning LED driver

**AF section**

- Electronic volume control
- FM muting

**Structure**

Bipolar monolithic IC

CXA1691M  
28 pin SOP (Plastic)

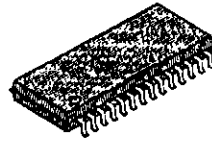

CXA1691S  
30 pin SDIP (Plastic)

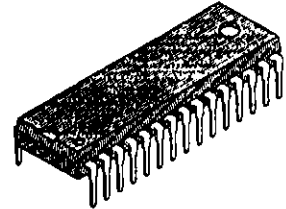

EEPW 电子产品世界 .com.cn

**Absolute Maximum Ratings (Ta=25°C)**

• Supply voltage	Vcc	14	V
• Operating temperature	Topr	-10 to +60	V
• Storage temperature	Tstg	-50 to +125	V
• Allowable power dissipation	PD	700	mW (CXA1691M)
	PD	1000	mW (CXA1691S)

**Recommended Operating Conditions**

Supply voltage	Vcc	2 to 7.5	V (CXA1691M)
	Vcc	2 to 8.5	V (CXA1691S)

**Block Diagram**

**CXA1691M**

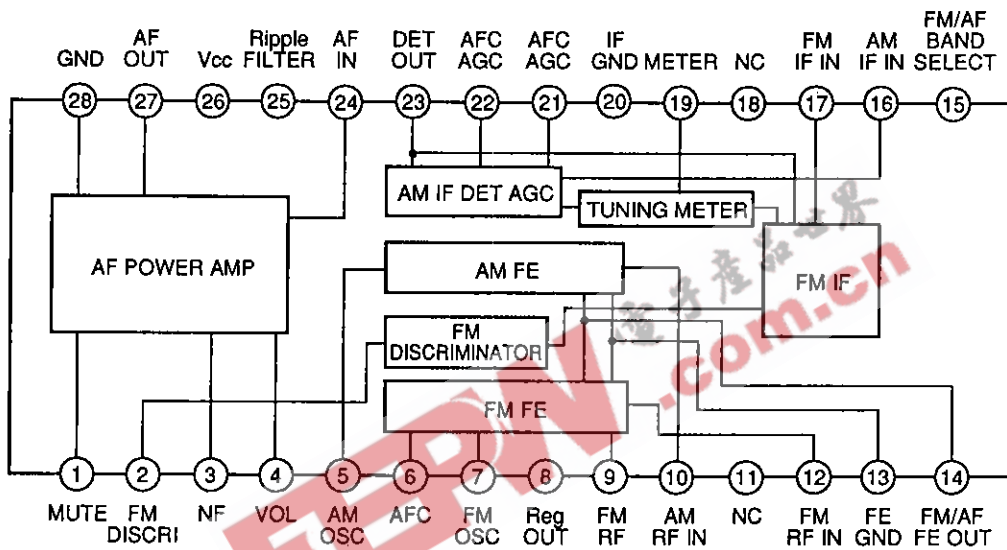

**CXA1691S**

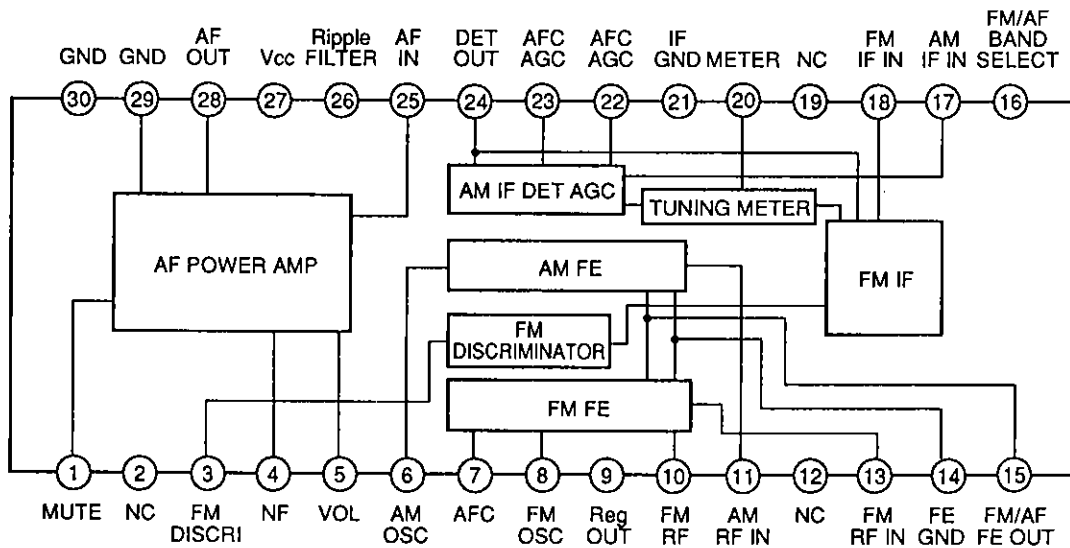

Standard Circuit Design Data

(The pin numbers in the parenthesis are for CXA1691S.)

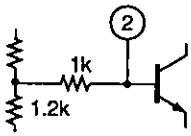
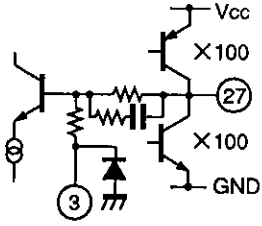
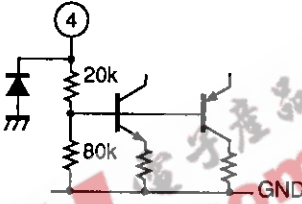
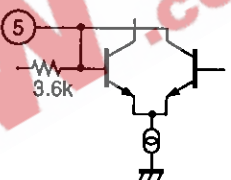
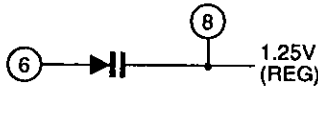
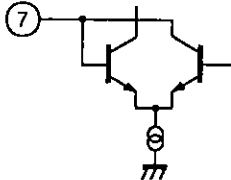
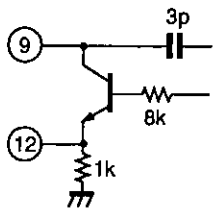
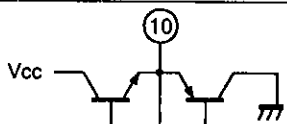
No.	Symbol	Voltage (V)				Equivalent circuit	Description
		Vcc=3V		Vcc=6V			
		FM	AM	FM	AM		
1 (1)	MUTE	0	0	0	0		
2 (3)	FM DISCRI	2.18	2.70	4.88	5.43		Phase-shift circuit Connect ceramic discriminator
3 (4)	NF	1.5	1.5	3.0	3.0		Negative feedback pin
27 (28)	AF OUT	1.5	1.5	3.0	3.0		Power amplifier output pin
4 (5)	VOL CONT	1.25	1.25	1.25	1.25		Connect variable resistor for electronic volume control.
5 (6)	AM OSC	1.25	1.25	1.25	1.25		AM local oscillation circuit
6 (7)	AFC	1.25	*	1.25	*		AFC variable capacitor pin
8 (9)	REG OUT	1.25	1.25	1.25	1.25		Regulator pin 1.25V (Typ.)
7 (8)	FM OSC	1.25	1.25	1.25	1.25		FM local oscillation circuit
9 (10)	FM RF	1.25	1.25	1.25	1.25		Connect FM RF tuning coil
12 (13)	FM RF IN	0.3	0	0.3	0		FM RF input pin
10 (11)	AM RF IN	1.25	1.25	1.25	1.25		AM RF input pin

No.	Symbol	Voltage (V)				Equivalent circuit	Description
		Vcc=3V		Vcc=6V			
		FM	AM	FM	AM		
11 (12)	NC	0	0	0	0		
13 (14)	GND (FE GND)	0	0	0	0		
14 (15)	FM/AM FE OUT	0.36	0.2	0.36	0.2		IF output pin of FM and AM. Connect IF filter
15 (16)	BAND SELECT	0.84	0	0.88	0		FM and AM bands selection switch pin. During GND it becomes AM and during open it becomes FM.
16 (17)	AM IF IN	0	0	0	0		Input pin of AM IF
17 (18)	FM IF IN	1.30	0	1.30	0		Input pin of FM IF
18 (19)	NC	0	0	0	0		
19 (20)	METER	1.6	1.6	4.5	4.5		Meter drive circuit (For tuning indicator)
20 (21)	GND	0	0	0	0		

No.	Symbol	Voltage (V)				Equivalent circuit	Description
		Vcc=3V		Vcc=6V			
		FM	AM	FM	AM		
21 (22)	AFC /AGC	1.25	1.49	1.25	1.49		AFC pin of W band. During AM, it determines time constant of AGC.
22 (23)	AFC /AGC	1.25	1.25	1.25	1.25		AFC pin of J band. During AM, it determines time constant of AGC.
23 (24)	DET OUT	1.25	1.0	1.25	1.0		Detection output pin
24 (25)	AF IN	0	0	0	0		Power amplifier input pin
25 (26)	RIPPLE FILTER	2.71	2.71	5.4	5.4		Ripple filter
26 (27)	Vcc	3.0	3.0	6.0	6.0		Power supply pin
28 (29)	GND	0	0	0	0		Power GND

\* The pin voltage of pin 6 during AM, it is the same pin voltage of pin 22 (23) during J BAND and is the same pin voltage of pin 21 (22) during W BAND.

**Electrical Characteristics**

(See the Electrical Characteristics Test Circuit,  $T_a=25^\circ\text{C}$ ,  $V_{CC}=6\text{V}$ )

No.	Item	Symbol	SW conditions						Test Point	Conditions	Min.	Typ.	Max.	Unit
			1	2	3	4	5	6						
1	AM circuit current	ID1	A	B	A	A	A	A	IA	No signal, AM	—	3.5	10.0	mA
2	FM circuit current	ID2	A	B	A	A	B	A	IA	No signal, FM	—	7.0	14.0	mA
3	FM front end voltage gain	GV1	A	B	A	A	B	A	VA	$V_{IN1}=40\text{dB}\mu\text{V}$ , 100MHz	32	39	46	dB
4	FM detection output level	VD1	A	—	—	A	B	A	VD	$V_{IN3}=90\text{dB}\mu\text{V}$ , 10.7MHz (1kHz, 22.5kHz DEV)	39	77.5	155	Vrms
5	FM IF knee level	VD2	A	—	—	A	B	A	VD	$V_{IN3}$ =level at a point 3dB down from $V_{IN3}=90\text{dB}\mu\text{V}$ , 10.7MHz (1kHz, 22.5kHz DEV)	—	24	32	dB $\mu\text{V}$
6	FM detection output distortion factor	THD1	A	—	—	A	B	A	VD	$V_{IN3}=90\text{dB}\mu\text{V}$ , 10.7MHz (1kHz, 75kHz DEV)	—	0.3	2.0	%
7	FM meter current	IB1	A	—	—	A	B	A	IM	$V_{IN3}=60\text{dB}\mu\text{V}$ , 10.7MHz	1.8	3.5	7.0	mA
8	AM front end voltage gain	GV2	A	A	A	A	A	A	VB	$V_{IN2}=60\text{dB}\mu\text{V}$ , 1660kHz	15	22	29	dB
9	AM IF voltage gain	GV3	A	A	—	A	A	A	VD	$V_{IN3}$ when 455kHz (1kHz 30% MOD) output is -34dBm	14	20	27	dB $\mu\text{V}$
10	AM detection output level	VD3	A	A	—	A	A	A	VD	$V_{IN3}=85\text{dB}\mu\text{V}$ , 455kHz (1kHz, 30% MOD)	39	77.5	155	Vrms
11	AM meter current	IB2	A	A	—	A	A	A	IM	$V_{IN3}=85\text{dB}\mu\text{V}$ , 455kHz (1kHz, 30% MOD)	1.3	3.0	7.0	mA
12	AM detection output distortion factor	THD2	A	A	B	A	A	A	VD	$V_{IN2}=95\text{dB}\mu\text{V}$ , 1660kHz (1kHz, 30% MOD) $V_{CC}=7.8\text{V}$	—	0.6	2.0	%
13	Audio voltage gain	GV4	A	—	—	—	—	B	VE	$V_{IN3}=60\text{dB}\mu\text{V}$ , 10.7MHz $V_{IN4}=-30\text{dBm}$ , 1kHz	27	31.5	36	dB
14	Audio distortion factor	THD3	A	—	—	—	—	B	VE	Distortion factor for output of 50mW $V_{IN3}=60\text{dB}\mu\text{V}$ , 10.7MHz $V_{IN4}=-20\text{dBm}$ , 1kHz	—	0.3	2.5	%
15	Muting level	VD4	A	—	—	—	—	B	VE	Muting level for 50mW output $V_{IN4}=-20\text{dBm}$ , 1kHz $V_{IN3}$ OFF	8	15	22	dB

0dB $\mu\text{V}=1\mu\text{V}$



Application Circuit 1

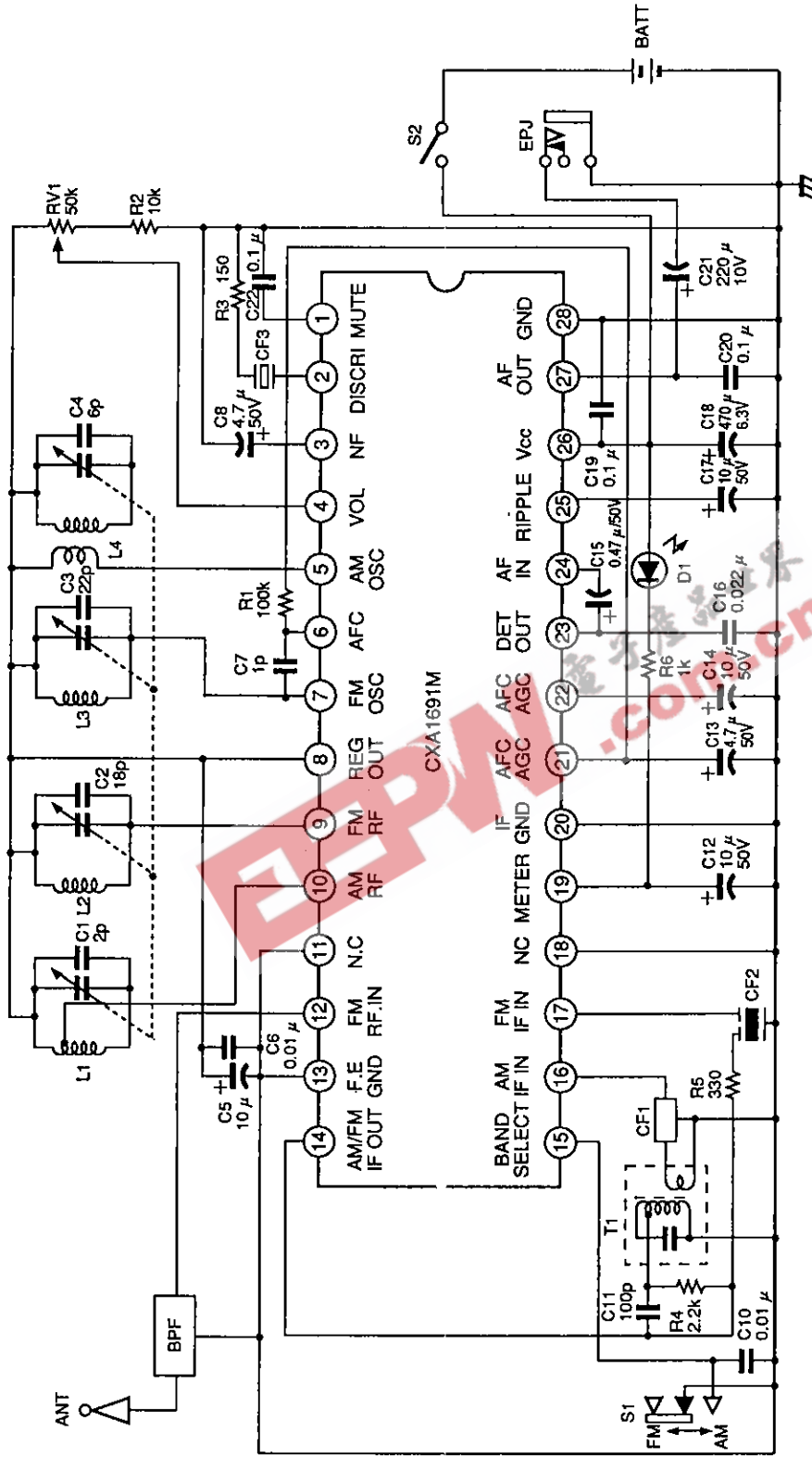

Application circuits shown are typical examples illustrating the operation of the devices. Sony cannot assume responsibility for any problems arising out of the use of these circuits or for any infringement of third party patent and other right due to same.



Application Circuit 2

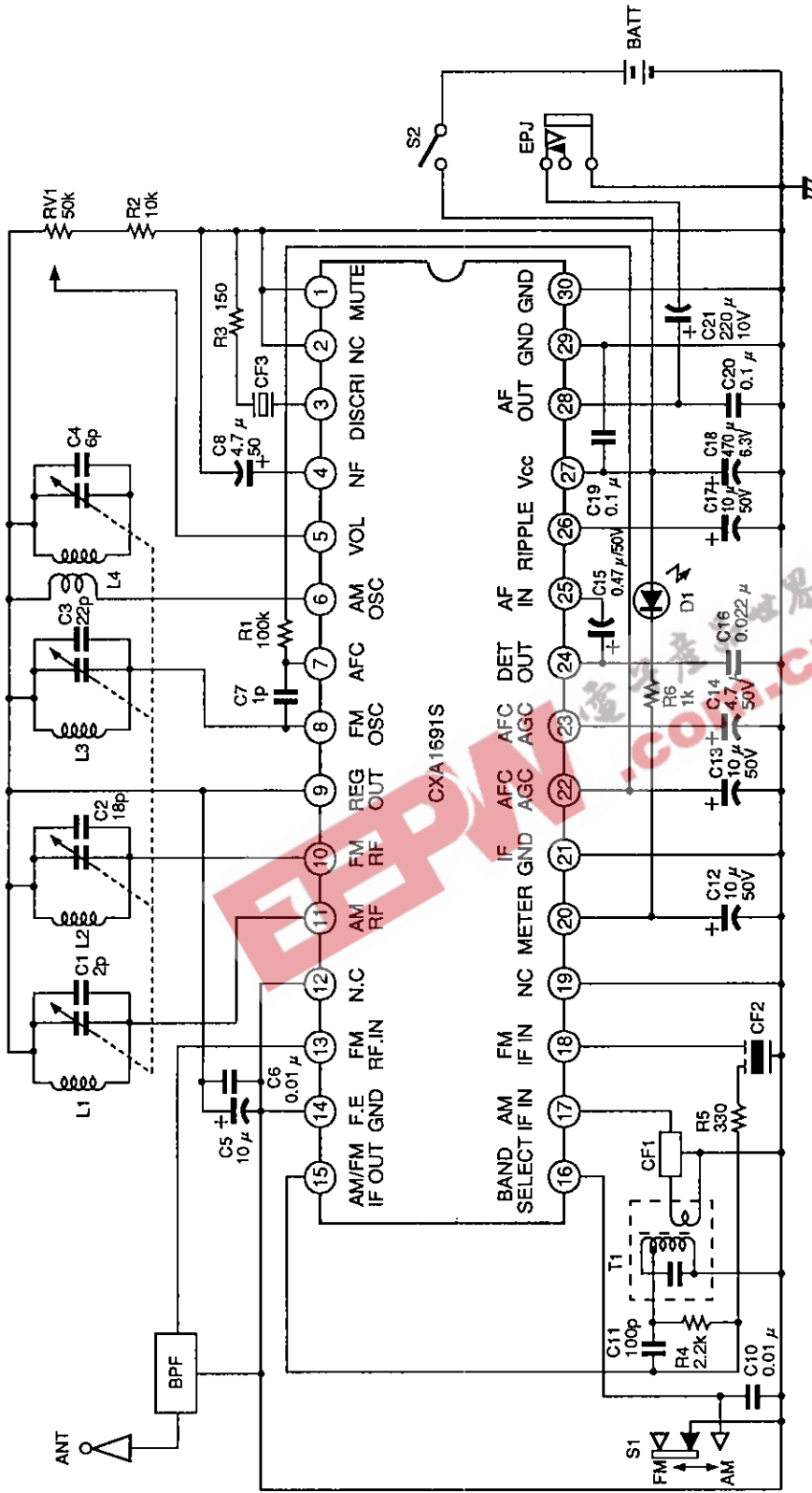

Application circuits shown are typical examples illustrating the operation of the devices. Sony cannot assume responsibility for any problems arising out of the use of these circuits or for any infringement of third party patent and other right due to same.

Coil data

AM OSC

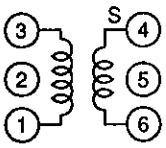

Core diameter  $\phi$  0.06mm 2UEW

f (kHz)	L ( $\mu$ H) 1 to 3	Qo 1 to 3	Number of windings (t)	
			1 to 3	4 to 6
796	270	125	107	29

Equivalent to L-5K7-H5 R12-1684X. Mitsumi Electric Co., Ltd.  
or 7TRS-8441X TOKO Co., Ltd.

AM IFT

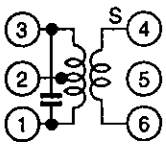

Core diameter  $\phi$  0.07mm UEW

Co (pF) 1 to 3	Qo 1 to 3	Number of windings (t)		
		1 to 2	2 to 3	4 to 6
180	90	111	35	7

Equivalent to 21K7-H5 R12-8558A. Mitsumi Electric Co., Ltd.  
or 7MC-7789N TOKO Co., Ltd.

FM RF

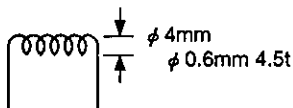

FM OSC

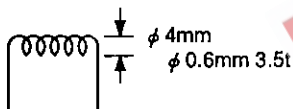

AM bar antenna

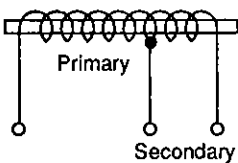

f (kHz)	L ( $\mu$ H)	Primary	Secondary
796	650	9t	20t

BPF PFW8  
(88 to 108MHz) Soshin Electric Co., Ltd.

CF1 SFU-455B Murata Mfg. Co., Ltd. Or BFCFL-455 TOKO Co., Ltd.

CF2 SFE10.7MA5 Murata Mfg. Co., Ltd.

CF3 CDA10.7MC1 Murata Mfg. Co., Ltd.

CXA1691M Evaluation Board

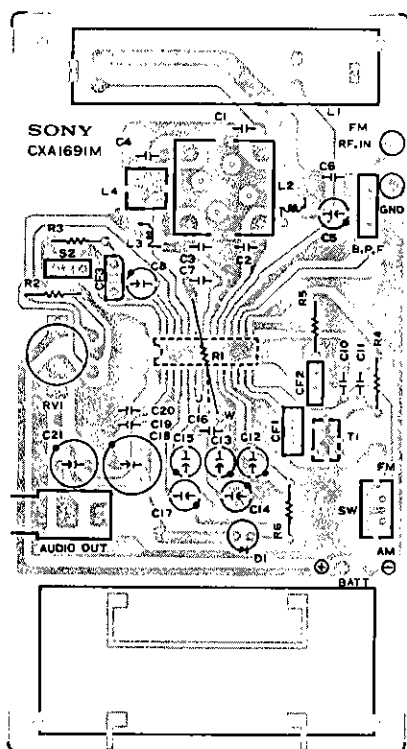

Parts layout (mounting side)

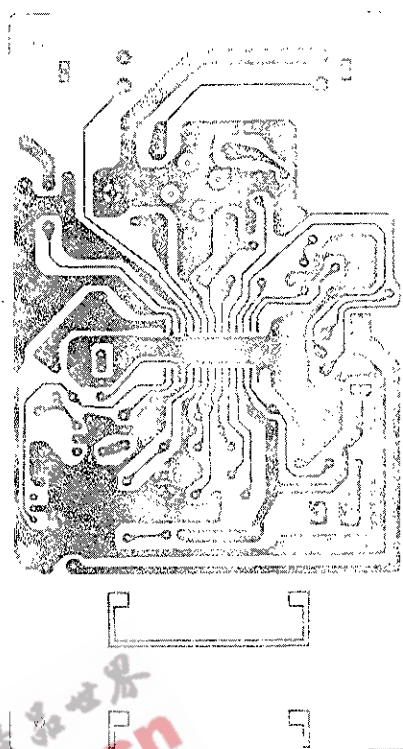

Pattern

CXA1691S Evaluation Board

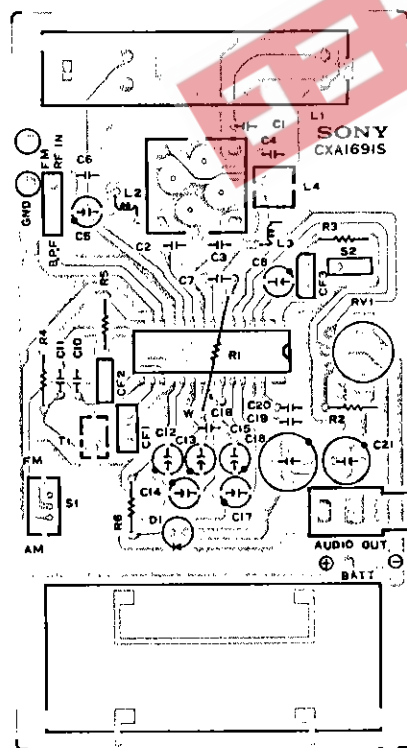

Parts layout (mounting side)

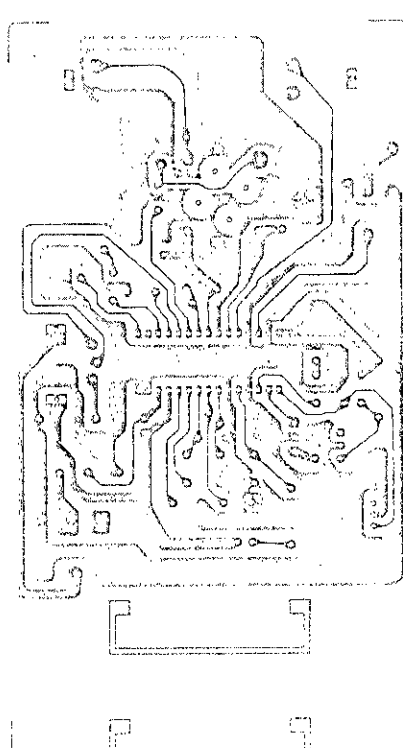

Pattern

Example of Representative Characteristics

AM FE+IF+AF Input-output characteristics

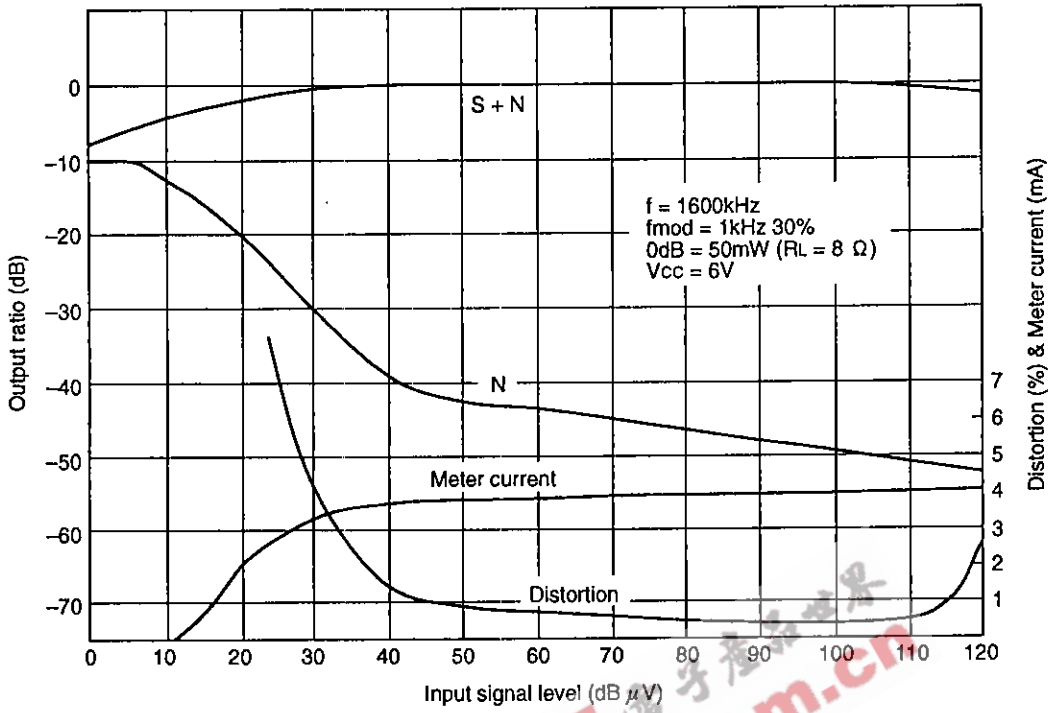

FM FE+IF+AF Input-output characteristics

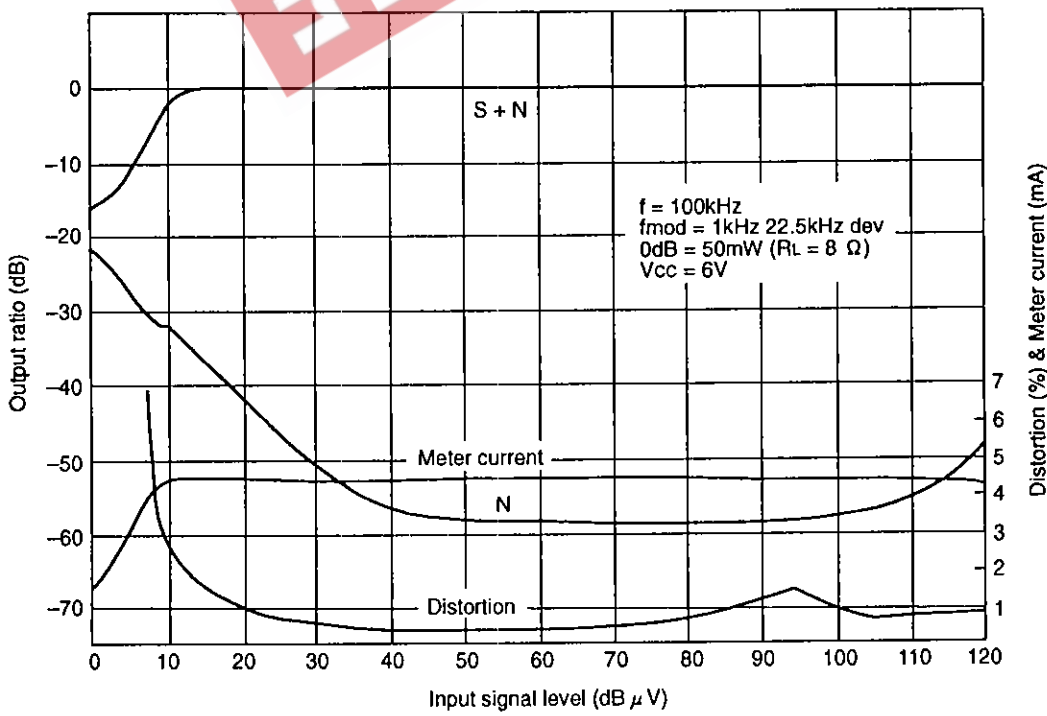

Package Outline

Unit : mm

CXA1691M

28 pin SOP (Plastic)

375mil 0.6g

375mil 0.7g

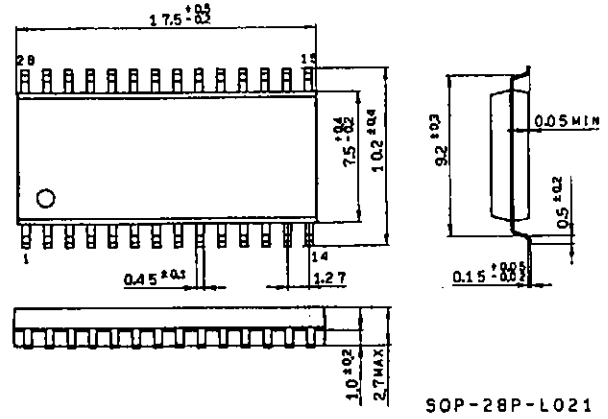
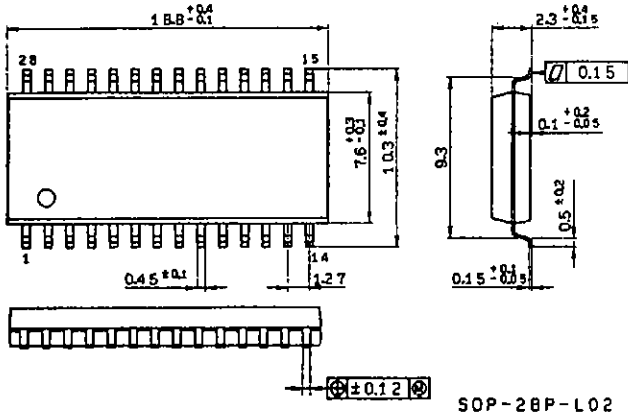

CXA1691S

30 pin SDIP (Plastic)

400mil 1.8g

400mil

