

MOS FET Relay

G3VM-353A/B/D/E

MOS FET Relay with N.C. (Normally Closed) Contacts for Switching Analog Signals

- SPST-NC contact form.
- Switches minute analog signals.
- Switches AC and DC.
- Low ON-resistance.
- UL/CSA approval pending.



■ Appearance

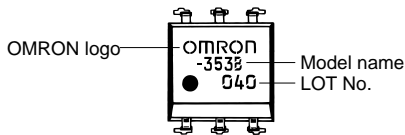

Note: "G3VM" is not printed on the actual product.

Ordering Information

Contact form	Terminals	Load voltage (peak value)	Model	Number per stick	Taping quantity
SPST-NC	PCB terminals	350 VAC	G3VM-353A	100	---
			G3VM-353B	50	
			G3VM-353D	100	
			G3VM-353E	50	
	Surface-mounting terminals		G3VM-353D(TR)	---	1,500
			G3VM-353E(TR)	---	

Application Examples

- Electronic automatic exchange systems
- Datacoms and modems
- Measuring systems
- Security systems
- FA

Specifications

■ G3VM-353A/D

Absolute Maximum Ratings (Ta = 25°C)

Item		Symbol	Rating	Conditions
Input	LED forward current	I_F	50 mA	---
	LED forward current reduction rate	$\Delta I_F/^\circ\text{C}$	-0.5 mA/°C	Ta ≥ 25°C
	Repetitive peak LED forward current	I_{FP}	1 A	100-μs pulses, 100 pps
	LED reverse voltage	V_R	5 V	---
	Permissible loss	P_{in}	50 mW	---
	Connection temperature	T_J	125°C	---
Output	Output dielectric strength	V_{OFF}	350 V	AC peak value
	Continuous load current	I_O	150 mA	---
	Peak load current	I_{peak}	0.35 A	---
	Output loss	P_{out}	506 mW	---
	ON current reduction rate	$\Delta I_{ON}/^\circ\text{C}$	-1.5 mA/°C	Ta ≥ 25°C
Total permissible loss		P_T	556 mW	---
Dielectric strength between I/O terminals (See note.)		V_{I-O}	2,500 Vrms	AC, 1 min
Insulation resistance		R_{I-O}	5×10^{10} MΩ	$V_S = 500$ V, ambient operating humidity ≤ 60%
Storage temperature		T_{stg}	-55 to 125°C	---
Ambient operating temperature		T_a	-40 to 85°C	---

Note The dielectric strength between I/O terminals was measured with voltage applied to all of the input pins and all of the output pins.

Electrical Performance (Ta = 25°C)

Item		Symbol	Minimum	Standard	Maximum	Conditions
Input	LED forward current	V_F	1.0 V	1.15 V	1.3 V	$I_F = 10$ mA
	Reverse current	I_R	---	---	10 μA	$V_R = 5$ V
	Capacity between terminals	C_T	---	30 pF	---	$V = 0$, $f = 1$ MHz
Output	Maximum resistance with output ON	R_{ON}	---	15 Ω	25 Ω	$I_{ON} = 150$ mA
	Current leakage when the relay is closed	I_{LEAK}	---	---	1 μA	$V_{OFF} = 350$ V, $I_F = 5$ mA
Turn-ON time		T_{ON}	---	0.1 ms	1 ms	$R_L = 200$ Ω (See note.) $V_{DD} = 20$ V, $I_F = 5$ mA
Turn-OFF time		T_{OFF}	---	1 ms	3 ms	
Floating capacity between I/O terminals		C_{I-O}	---	0.8 pF	---	$V_S = 0$ V, $f = 1$ MHz

Note The operate and release time were measured in the way shown below.

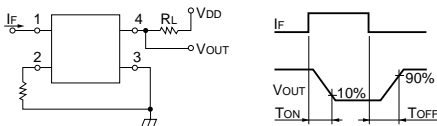

Recommended Operating Conditions

Item	Symbol	Minimum	Standard	Maximum
Operating voltage	V_{DD}	---	---	280 V
Forward current	I_F	5 mA	---	25 mA
Continuous load current	I_O	---	---	150 mA
Operating temperature	T_a	-20°C	---	65°C

■ G3VM-353B/E

Absolute Maximum Ratings (Ta = 25°C)

Item		Symbol	Rating	Conditions	
Input	LED forward current	I_F	50 mA	---	
	LED forward current reduction rate	$\Delta I_F/^\circ\text{C}$	-0.5 mA/°C	Ta ≥ 25°C	
	Repetitive peak LED forward current	I_{FP}	1 A	100- μs pulses, 100 pps	
	LED reverse voltage	V_R	5 V	---	
	Permissible loss	P_{in}	50 mW	---	
	Connection temperature	T_J	125°C	---	
Output	Output dielectric strength	V_{OFF}	350 V	AC peak value	
	Continuous load current (See note.)	A connection	I_O	150 mA	---
		B connection		150 mA	
		C connection		300 mA	
	Peak load current	I_{peak}	0.35 A	---	
	Output loss	P_{out}	506 mW	---	
	ON current reduction rate	A connection	$\Delta I_{ON}/^\circ\text{C}$	-1.5 mA/°C	Ta ≥ 25°C
		B connection		-1.5 mA/°C	
C connection		-3.0 mA/°C			
Total permissible loss		P_T	556 mW	---	
Dielectric strength between I/O terminals (See note.)		V_{I-O}	2,500 Vrms	AC, 1 min	
Insulation resistance		R_{I-O}	5×10^{10} M Ω	V _S = 500 V, ambient operating humidity ≤ 60%	
Storage temperature		T _{stg}	-55 to 125°C	---	
Ambient operating temperature		T _a	-40 to 85°C	---	

Note The dielectric strength between I/O terminals was measured with voltage applied to pins 1, 2, and 3 together, and to pins 4, 5, and 6 together.

Connection Circuit Diagram

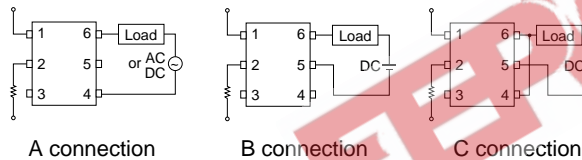

Electrical Performance (Ta = 25°C)

Item		Symbol	Minimum	Standard	Maximum	Conditions	
Input	LED forward current	V_F	1.0 V	1.15 V	1.3 V	$I_F = 10 \text{ mA}$	
	Reverse current	I_R	---	---	10 μA	$V_R = 5 \text{ V}$	
	Capacity between terminals	C_T	---	30 pF	---	$V = 0, f = 1 \text{ MHz}$	
Output	Maximum resistance with output ON	A connection	---	15 Ω	25 Ω	$I_{ON} = 150 \text{ mA}$	
		B connection	R_{ON}	---	8 Ω	14 Ω	$I_{ON} = 150 \text{ mA}$
		C connection	---	4 Ω	7 Ω	$I_{ON} = 300 \text{ mA}$	
	Current leakage when the relay is closed	I_{LEAK}	---	---	1 μA	$V_{OFF} = 350 \text{ V}, I_F = 5 \text{ mA}$	
Operate time		T_{ON}	---	0.1 ms	1 ms	$R_L = 200 \Omega$ (See note.) $V_{DD} = 20 \text{ V},$ $I_F = 5 \text{ mA}$	
Release time		T_{OFF}	---	1 ms	3 ms		
Floating capacity between I/O terminals		C_{I-O}	---	0.8 pF	---	$V_S = 0 \text{ V}, f = 1 \text{ MHz}$	

Note The operate and release time were measured in the way shown below.

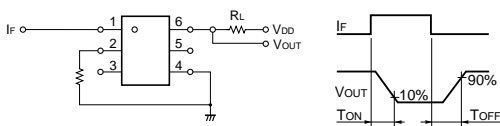

Recommended Operating Conditions

Item	Symbol	Minimum	Standard	Maximum
Operating voltage	V_{DD}	---	---	280 V
Forward current	I_F	5 mA	---	25 mA
Continuous load current	I_O	---	---	150 mA
Operating temperature	T_a	-20°C	---	65°C

Dimensions

Note All units are in millimeters unless otherwise indicated.

G3VM-353A

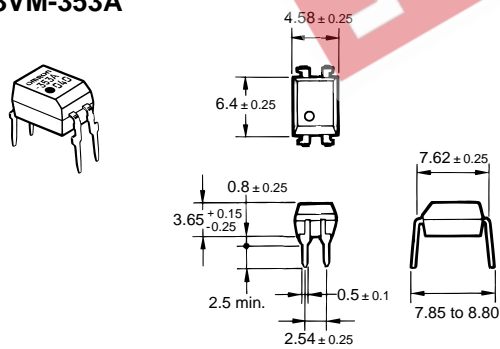

Weight: 0.26 g

G3VM-353D

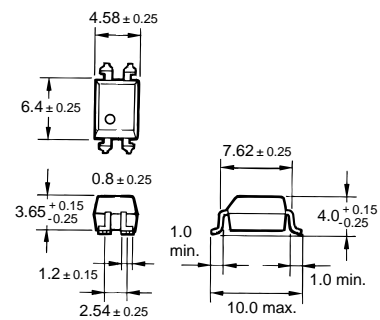

Weight: 0.26 g

Note: "G3VM" is not printed on the actual product.

G3VM-353B

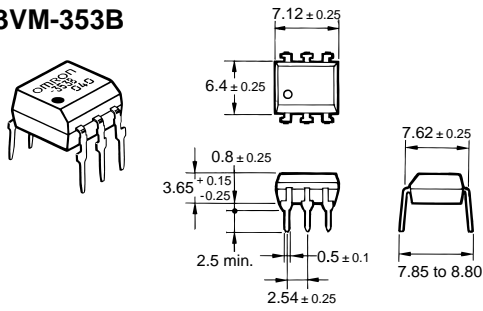

Weight: 0.4 g

Note: "G3VM" is not printed on the actual product.

G3VM-353E

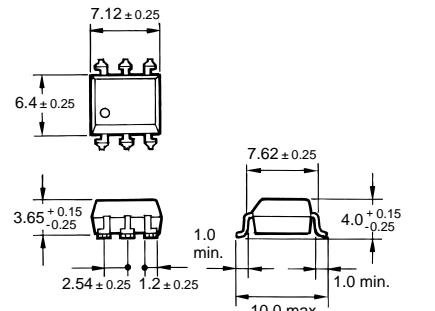

Weight: 0.4 g

■ **PCB Dimensions (Bottom View)**

G3VM-353A

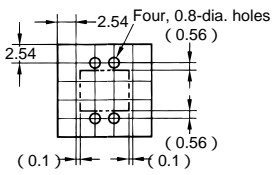

G3VM-353B

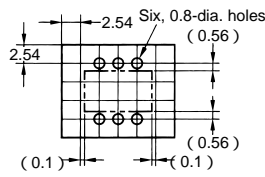

■ **Actual Mounting Pad Dimensions (Recommended Value, Top View)**

G3VM-353D

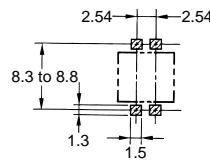

G3VM-353E

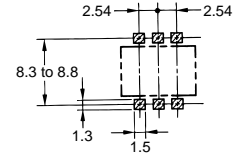

Installation

■ **Terminal Arrangement/Internal Connection (Top View)**

G3VM-353A

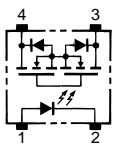

G3VM-353B

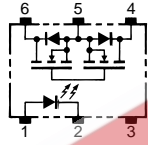

G3VM-353D

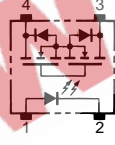

G3VM-353E

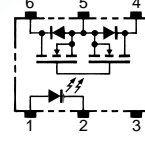

Precautions

! WARNING

Be sure to turn OFF the power when wiring the Relay, otherwise an electric shock may be received.

! WARNING

Do not touch the charged terminals of the SSR, otherwise an electric shock may be received.

! Caution

Do not apply overvoltage or overcurrent to the I/O circuits of the SSR, otherwise the SSR may malfunction or burn.

! Caution

Be sure to wire and solder the Relay under the proper soldering conditions, otherwise the Relay in operation may generate excessive heat and the Relay may burn.

Correct Use

Typical Relay Driving Circuit Examples

C-MOS

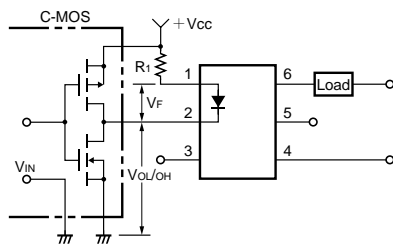

Transistor

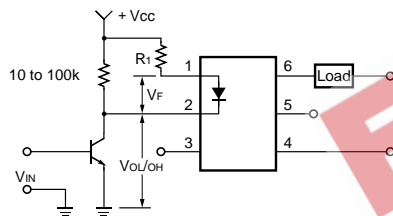

Use the following formula to obtain the LED current limiting resistance value to assure that the relay operates accurately.

$$R_1 = \frac{V_{CC} - V_{OL} - V_F(ON)}{5 \text{ to } 20 \text{ mA}}$$

Use the following formula to obtain the LED forward voltage value to assure that the relay releases accurately.

$$V_{F(OFF)} = V_{CC} - V_{OH} < 0.8 \text{ V}$$

Protection from Surge Voltage on the Input Terminals

If any reversed surge voltage is imposed on the input terminals, insert a diode in parallel to the input terminals as shown in the following circuit diagram and do not impose a reversed voltage value of 3 V or more.

Surge Voltage Protection Circuit Example

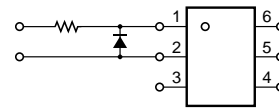

Protection from Spike Voltage on the Output Terminals

If a spike voltage exceeding the absolute maximum rated value is generated between the output terminals, insert a C-R snubber or clamping diode in parallel to the load as shown in the following circuit diagram to limit the spike voltage.

Spike Voltage Protection Circuit Example

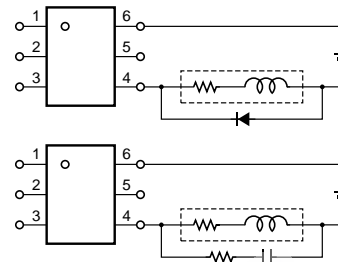

Unused Terminals (6-pin only)

Terminal 3 is connected to the internal circuit. Do not connect anything to terminal 3 externally.

Pin Strength for Automatic Mounting

In order to maintain the characteristics of the relay, the force imposed on any pin of the relay for automatic mounting must not exceed the following.

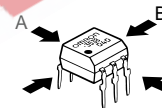

In direction A: 1.96 N max.
In direction B: 1.96 N max.

Load Connection

Do not short-circuit the input and output terminals while the relay is operating or the relay may malfunction.

AC Connection

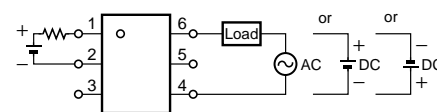

DC Single Connection

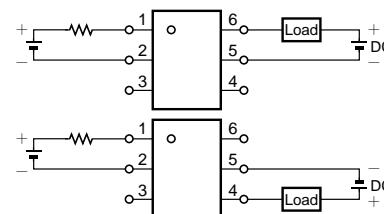

DC Parallel Connection

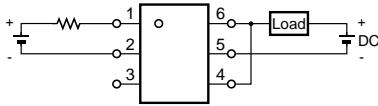

Solder Mounting

Maintain the following conditions during manual or reflow soldering of the relays in order to prevent the temperature of the relays from rising.

1. Pin Soldering
Solder each pin at a maximum temperature of 260°C within 10 s.
2. Reflow Soldering
 - a. Solder each pin at a maximum temperature of 260°C within 10 s.
 - b. Make sure that the ambient temperature on the surface of the resin casing is 240°C max. for 10 s maximum.
 - c. The following temperature changes are recommendable for soldering.

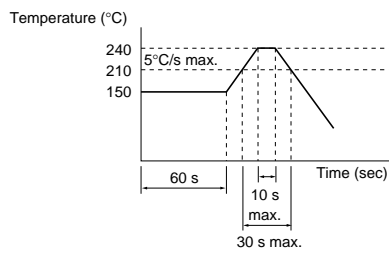

EEPW 电子产品世界
.com.cn



ALL DIMENSIONS SHOWN ARE IN MILLIMETERS.
To convert millimeters into inches, multiply by 0.03937. To convert grams into ounces, multiply by 0.03527.

Cat. No. K115-E1-1 **In the interest of product improvement, specifications are subject to change without notice.**

OMRON Corporation

Electronics Components Company

Electronic & Mechanical Components Division H.Q.
Low Signal Relay Division
2-1, 2-chome, Nishikusatsu, Kusatsu-city,
Siga-pref., 525-0035 Japan
Phone: (81)77-565-5481 Fax: (81)77-565-5581

Printed in Japan
0201-2M (0201) (A)