



DAC7621

For most current data sheet and other product information, visit www.burr-brown.com

12-Bit, Parallel Input DIGITAL-TO-ANALOG CONVERTER

FEATURES

- **LOW POWER:** 2.5mW
- **FAST SETTLING:** 7 μ s to 1 LSB
- **1mV LSB WITH 4.095V FULL-SCALE RANGE**
- **COMPLETE WITH REFERENCE**
- **12-BIT LINEARITY AND MONOTONICITY OVER INDUSTRIAL TEMP RANGE**
- **ASYNCHRONOUS RESET TO 0V**

APPLICATIONS

- **PROCESS CONTROL**
- **DATA ACQUISITION SYSTEMS**
- **CLOSED-LOOP SERVO-CONTROL**
- **PC PERIPHERALS**
- **PORTABLE INSTRUMENTATION**

DESCRIPTION

The DAC7621 is a 12-bit digital-to-analog converter (DAC) with guaranteed 12-bit monotonicity performance over the industrial temperature range. It requires a single +5V supply and contains an input register, latch, 2.435V reference, DAC, and high speed rail-to-rail output amplifier. For a full-scale step, the output will settle to 1 LSB within 7 μ s. The device consumes 2.5mW (0.5mA at 5V).

The parallel interface is compatible with a wide variety of microcontrollers. The DAC7621 accepts a 12-bit parallel word, has a double-buffered input logic structure and provides data readback. In addition, two control pins provide a chip select (\overline{CS}) function and asynchronous clear (CLR) input. The CLR input can be used to ensure that the DAC7621 output is 0V on power-up or as required by the application.

The DAC7621 is available in a 20-lead SSOP package and is fully specified over the industrial temperature range of -40°C to +85°C.

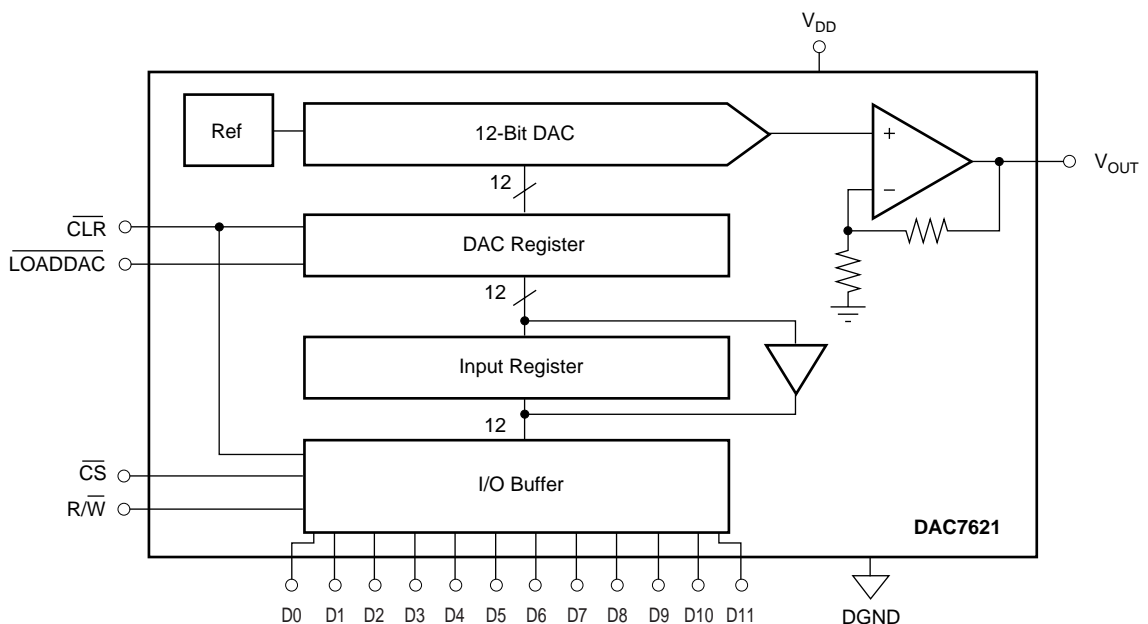

International Airport Industrial Park • Mailing Address: PO Box 11400, Tucson, AZ 85734 • Street Address: 6730 S. Tucson Blvd., Tucson, AZ 85706 • Tel: (520) 746-1111
 Twx: 910-952-1111 • Internet: <http://www.burr-brown.com/> • Cable: BBRCORP • Telex: 066-6491 • FAX: (520) 889-1510 • Immediate Product Info: (800) 548-6132

SPECIFICATIONS

ELECTRICAL

At $T_A = -40^{\circ}\text{C}$ to $+85^{\circ}\text{C}$, and $V_{DD} = +5\text{V}$, unless otherwise noted.

PARAMETER	CONDITIONS	DAC7621E			DAC7621EB			UNITS
		MIN	TYP	MAX	MIN	TYP	MAX	
RESOLUTION		12			*			Bits
ACCURACY								
Relative Accuracy ⁽¹⁾	Guaranteed Monotonic Code 000 _H Code FFF _H	-2	±1/2	+2	-1	±1/4	+1	LSB
Differential Nonlinearity		-1	±1/2	+1	-1	±1/4	+1	LSB
Zero-Scale Error		-1	+1	+3	*	*	*	LSB
Full Scale Voltage		4.079	4.095	4.111	4.087	4.095	4.103	V
ANALOG OUTPUT								
Output Current	Code 800 _H $R_{LOAD} \geq 402\Omega$, Code 800 _H	±5	±7		*	*	*	mA
Load Regulation		1	3		*	*	*	LSB
Capacitive Load	No Oscillation GND or V_{DD}		500		*	*	*	pF
Short-Circuit Current			±20		*	*	*	mA
Short-Circuit Duration			Indefinite		*	*	*	
DIGITAL INPUT								
Data Format	Parallel Straight Binary CMOS	$0.7 \cdot V_{DD}$				*		
Data Coding						*		
Logic Family						*		
Logic Levels								
V_{IH}					*		V	
V_{IL}						*	V	
I_{IH}						*	μA	
I_{IL}						*	μA	
DYNAMIC PERFORMANCE								
Settling Time ⁽²⁾ (t_s)	To ±1 LSB of Final Value		7			*		μs
DAC Glitch			5			*		nV-s
Digital Feedthrough			2			*		nV-s
POWER SUPPLY								
V_{DD}	$V_{IH} = 5\text{V}$, $V_{IL} = 0\text{V}$, No Load, at Code 000 _H $V_{IH} = 5\text{V}$, $V_{IL} = 0\text{V}$, No Load $\Delta V_{DD} = \pm 5\%$	+4.75	+5.0	+5.25	*	*	*	V
I_{DD}			0.5	1		*	*	mA
Power Dissipation			2.5	5		*	*	mW
Power Supply Sensitivity			0.001	0.004		*	*	%/%
TEMPERATURE RANGE								
Specified Performance		-40		+85	*		*	°C

* Same specification as for DAC7621E.

NOTES: (1) This term is sometimes referred to as Linearity Error or Integral Nonlinearity (INL). (2) Specification does not apply to negative-going transitions where the final output voltage will be within 3 LSBs of ground. In this region, settling time may be double the value indicated.

The information provided herein is believed to be reliable; however, BURR-BROWN assumes no responsibility for inaccuracies or omissions. BURR-BROWN assumes no responsibility for the use of this information, and all use of such information shall be entirely at the user's own risk. Prices and specifications are subject to change without notice. No patent rights or licenses to any of the circuits described herein are implied or granted to any third party. BURR-BROWN does not authorize or warrant any BURR-BROWN product for use in life support devices and/or systems.

PIN CONFIGURATION

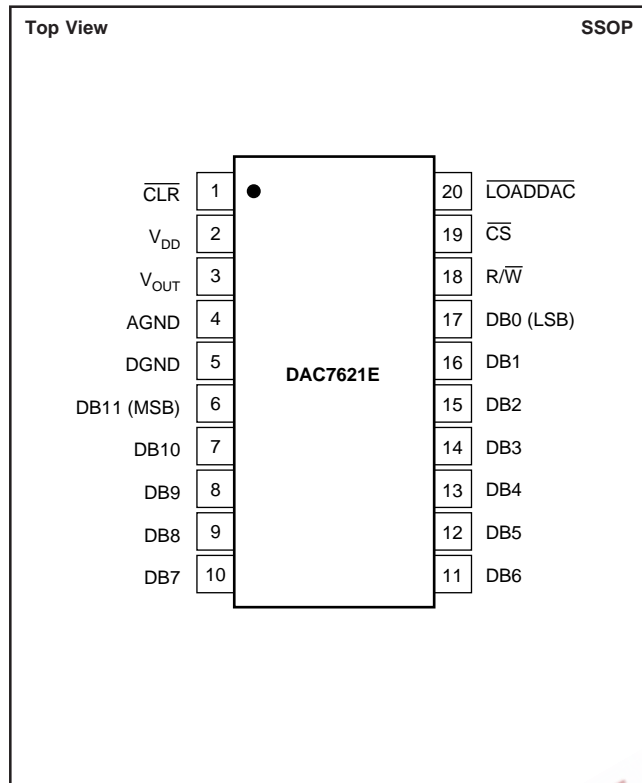

PIN DESCRIPTIONS

PIN	LABEL	DESCRIPTION
1	$\overline{\text{CLR}}$	Reset. Resets the DAC register to zero. Active LOW. Asynchronous input.
2	V_{DD}	Positive Power Supply
3	V_{OUT}	DAC Output Voltage
4	AGND	Analog Ground
5	DGND	Digital Ground
6	DB11	Data Bit 11, MSB
7	DB10	Data Bit 10
8	DB9	Data Bit 9
9	DB8	Data Bit 8
10	DB7	Data Bit 7
11	DB6	Data Bit 6
12	DB5	Data Bit 5
13	DB4	Data Bit 4
14	DB3	Data Bit 3
15	DB2	Data Bit 2
16	DB1	Data Bit 1
17	DB0	Data Bit 0, LSB
18	$\overline{\text{R/W}}$	Read and Write Control
19	$\overline{\text{CS}}$	Chip Select. Active LOW.
20	LOADDAC	Loads the internal DAC register. The DAC register is a transparent latch and is transparent when LOADDAC is LOW (regardless of the state of $\overline{\text{CS}}$ or CLK).

ABSOLUTE MAXIMUM RATINGS⁽¹⁾

V_{DD} to GND	-0.3V to 6V
Digital Inputs to GND	-0.3V to $V_{\text{DD}} + 0.3\text{V}$
V_{OUT} to GND	-0.3V to $V_{\text{DD}} + 0.3\text{V}$
Power Dissipation	325mW
Thermal Resistance, θ_{JA}	150°C/W
Maximum Junction Temperature	+150°C
Operating Temperature Range	-40°C to +85°C
Storage Temperature Range	-65°C to +150°C
Lead Temperature (soldering, 10s)	+300°C

NOTE: (1) Stresses above those listed under "Absolute Maximum Ratings" may cause permanent damage to the device. Exposure to absolute maximum conditions for extended periods may affect device reliability.



ELECTROSTATIC DISCHARGE SENSITIVITY

This integrated circuit can be damaged by ESD. Burr-Brown recommends that all integrated circuits be handled with appropriate precautions. Failure to observe proper handling and installation procedures can cause damage.

ESD damage can range from subtle performance degradation to complete device failure. Precision integrated circuits may be more susceptible to damage because very small parametric changes could cause the device not to meet its published specifications.

PACKAGE/ORDERING INFORMATION

PRODUCT	MINIMUM RELATIVE ACCURACY (LSB)	DIFFERENTIAL NONLINEARITY (LSB)	SPECIFICATION TEMPERATURE RANGE	PACKAGE	PACKAGE DRAWING NUMBER ⁽¹⁾	ORDERING NUMBER ⁽²⁾	TRANSPORT MEDIA
DAC7621E	±2	±1	-40°C to +85°C	20-Lead SSOP	334	DAC7621E	Rails
"	"	"	"	"	"	DAC7621E/1K	Tape and Reel
DAC7621EB	±1	±1	-40°C to +85°C	20-Lead SSOP	334	DAC7621EB	Rails
"	"	"	"	"	"	DAC7621EB/1K	Tape and Reel

NOTES: (1) For detailed drawing and dimension table, please see end of data sheet, or Appendix C of Burr-Brown IC Data Book. (2) Models with a slash (/) are available only in Tape and Reel in the quantities indicated (e.g., /1K indicates 1000 devices per reel). Ordering 1000 pieces of "DAC7621E/1K" will get a single 1000-piece Tape and Reel. For detailed Tape and Reel mechanical information, refer to Appendix B of Burr-Brown IC Data Book.

TIMING DIAGRAMS

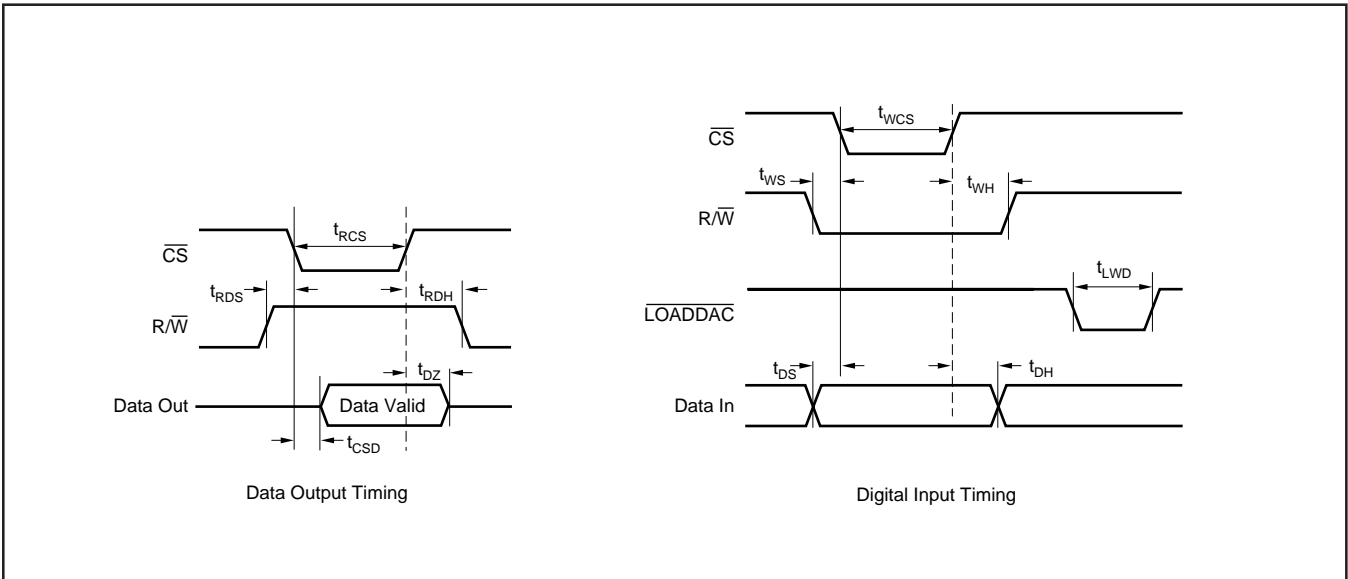

TIMING SPECIFICATIONS

$T_A = -40^\circ\text{C}$ to $+85^\circ\text{C}$

SYMBOL	DESCRIPTION	MIN	TYP	MAX	UNITS
t_{RCS}	\overline{CS} LOW for Read	200			ns
t_{RDS}	R/\overline{W} HIGH to \overline{CS} LOW	10			ns
t_{RDH}	R/\overline{W} HIGH after \overline{CS} HIGH	0			ns
t_{DZ}	\overline{CS} HIGH to Data Bus in High Impedance		100		ns
t_{CSD}	\overline{CS} LOW to Data Bus Valid		100	160	ns
t_{WCS}	\overline{CS} LOW for Write	50			ns
t_{WS}	R/\overline{W} LOW to \overline{CS} LOW	0			ns
t_{WH}	R/\overline{W} LOW after \overline{CS} HIGH	5			ns
t_{DS}	Data Valid to \overline{CS} LOW	0			ns
t_{DH}	Data Valid after \overline{CS} HIGH	5			ns
t_{LWD}	$\overline{LOADDAC}$ LOW	50			ns

LOGIC TRUTH TABLE

R/\overline{W}	\overline{CS}	$\overline{LOADDAC}$	INPUT REGISTER	DAC REGISTER	MODE
L	L	L	Write	Write	Write
L	L	H	Write	Hold	Write Input
H	L	H	Read	Hold	Read Input
X	H	L	Hold	Update	Update
X	H	H	Hold	Hold	Hold

X = Don't Care.

TYPICAL PERFORMANCE CURVES

At $T_A = +25^\circ$, and $V_{DD} = 5V$, unless otherwise specified.

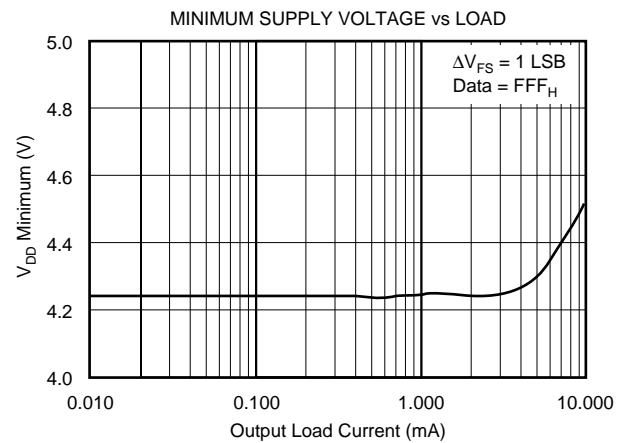
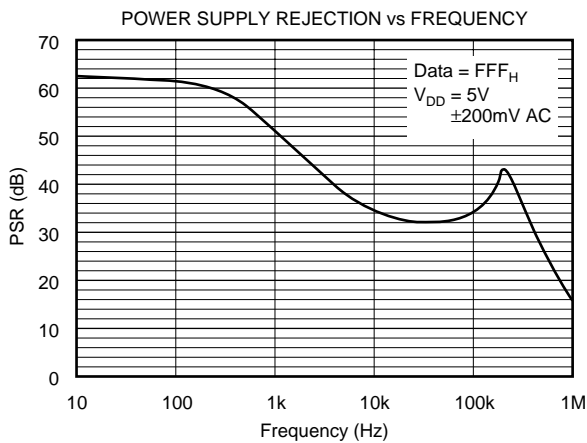
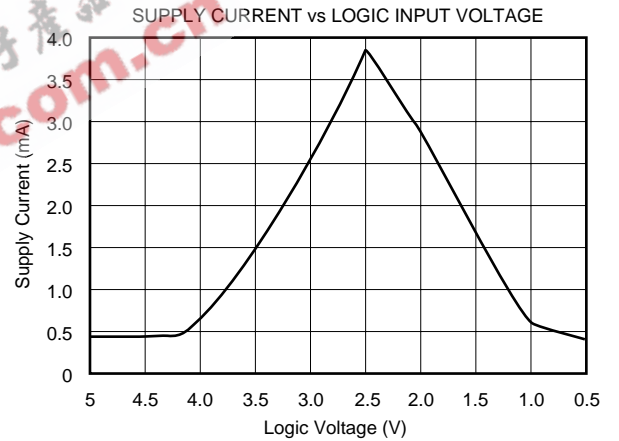
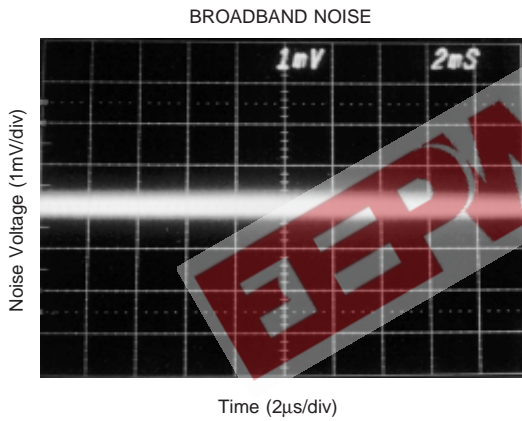
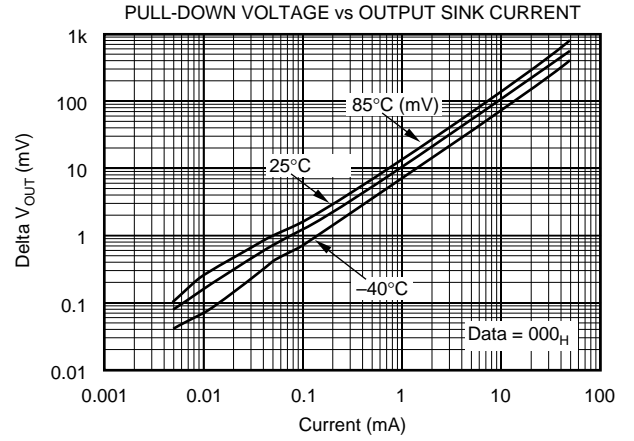
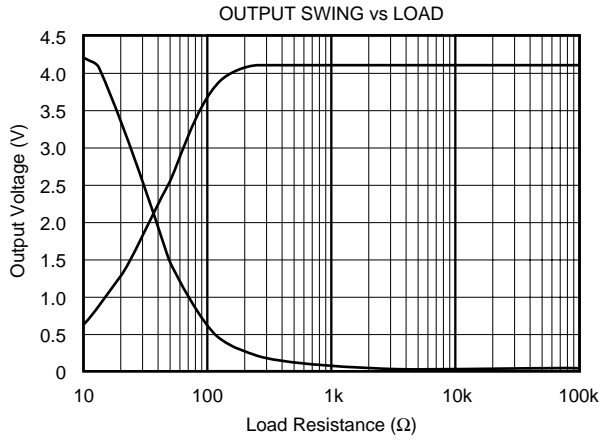

TYPICAL PERFORMANCE CURVES (CONT)

At $T_A = +25^\circ$, and $V_{DD} = 5V$, unless otherwise specified.

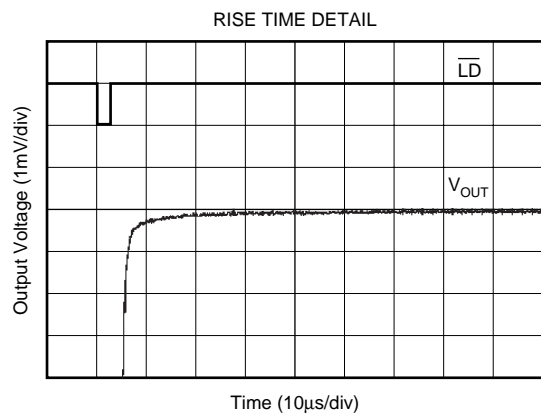
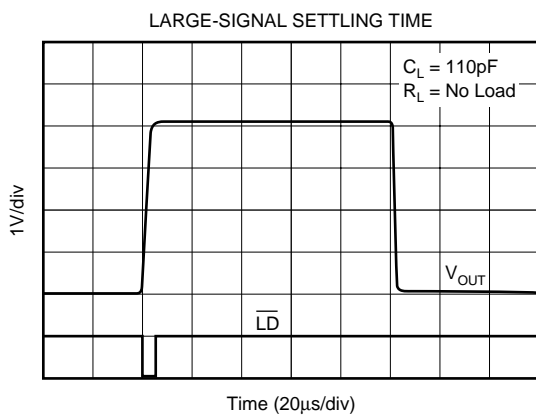
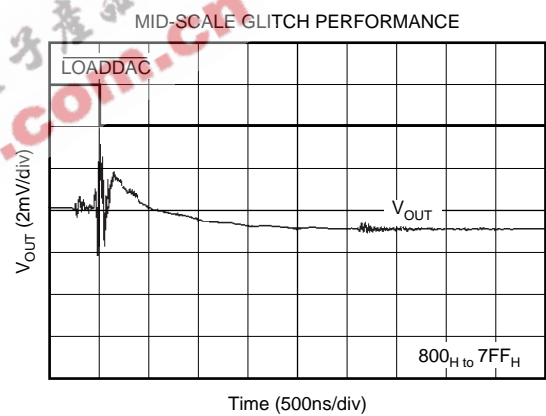
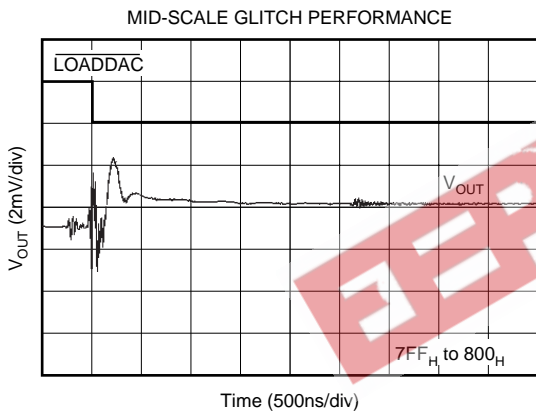
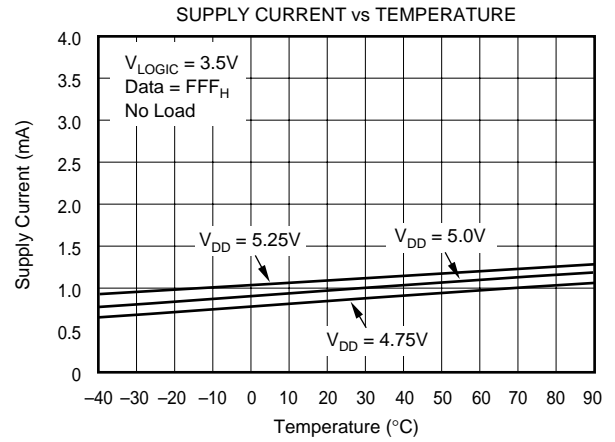
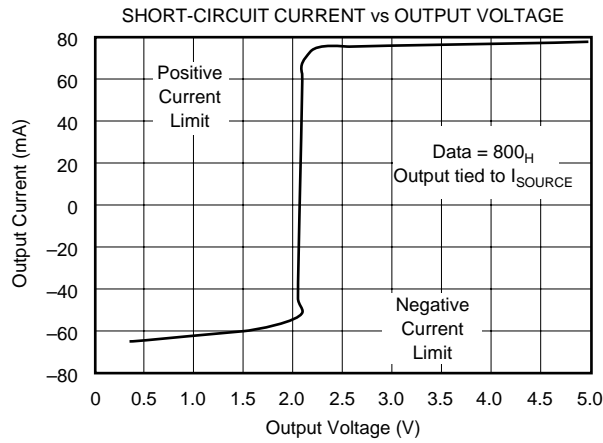

TYPICAL PERFORMANCE CURVES (CONT)

At $T_A = +25^\circ$, and $V_{DD} = 5V$, unless otherwise specified.

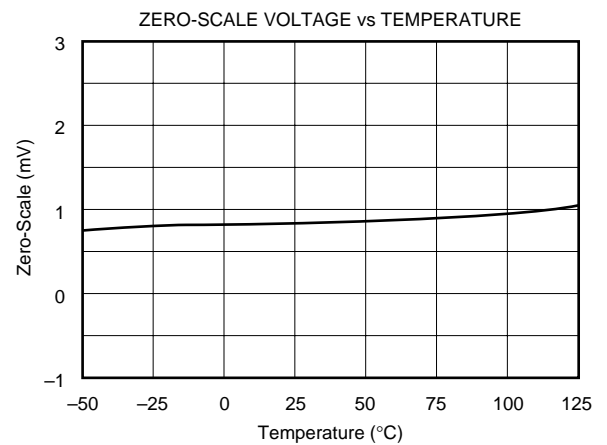
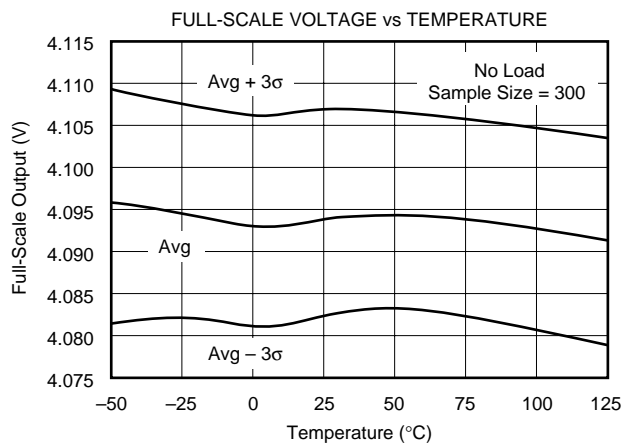
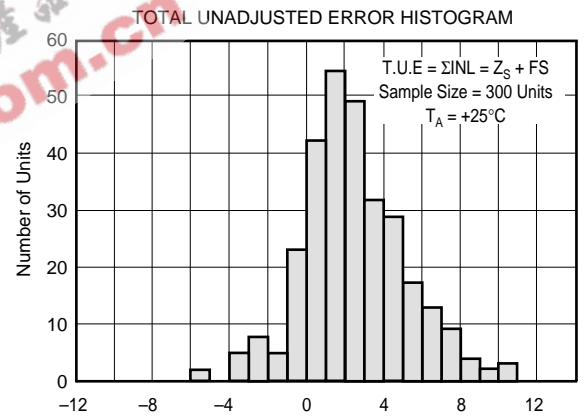
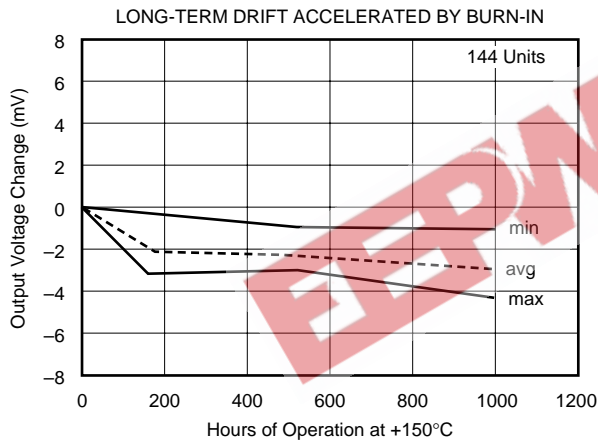
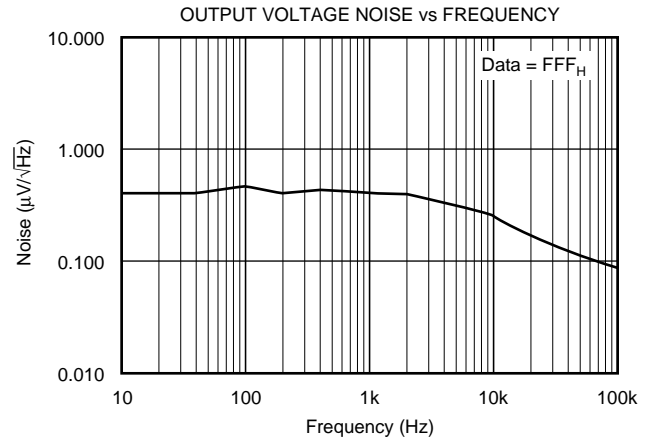
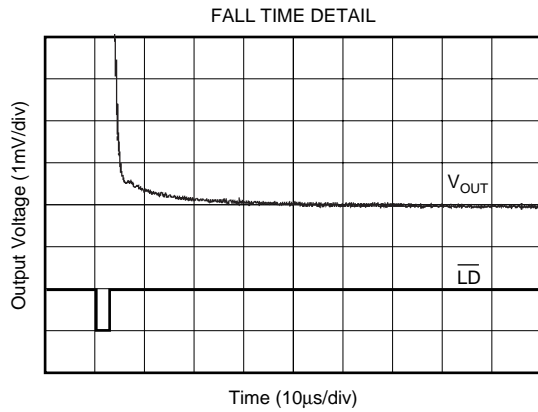

TYPICAL PERFORMANCE CURVES (CONT)

At $T_A = +25^\circ$, and $V_{DD} = 5V$, unless otherwise specified.

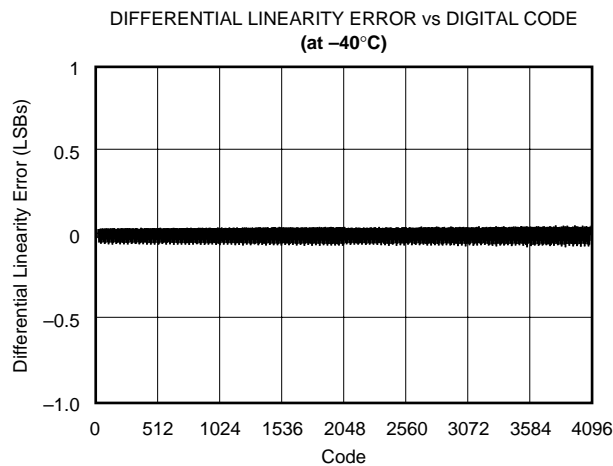
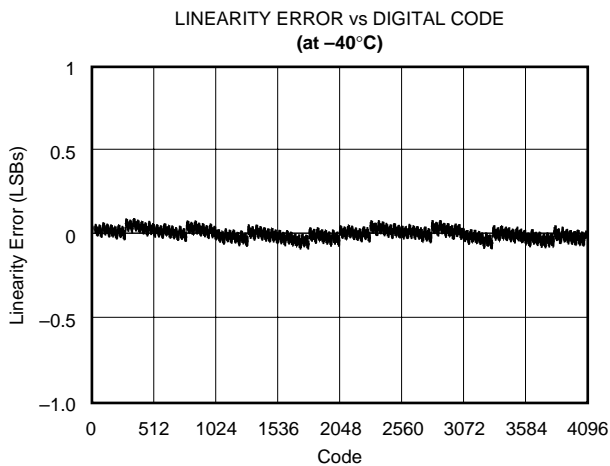
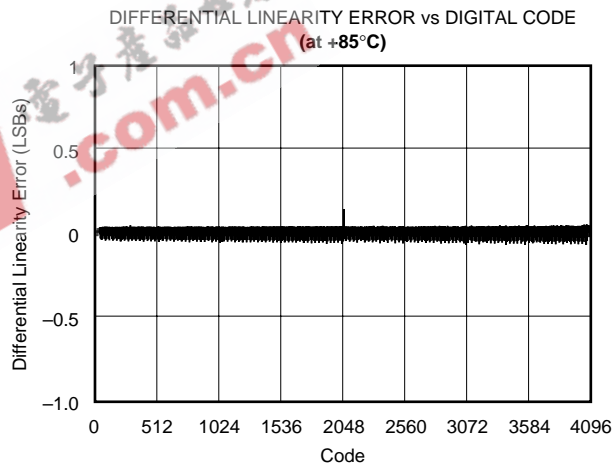
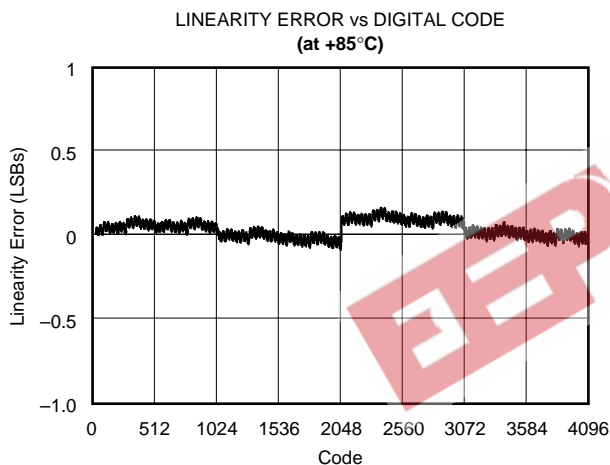
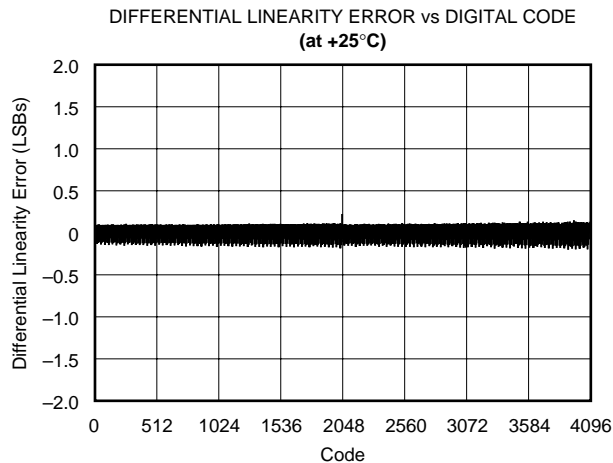
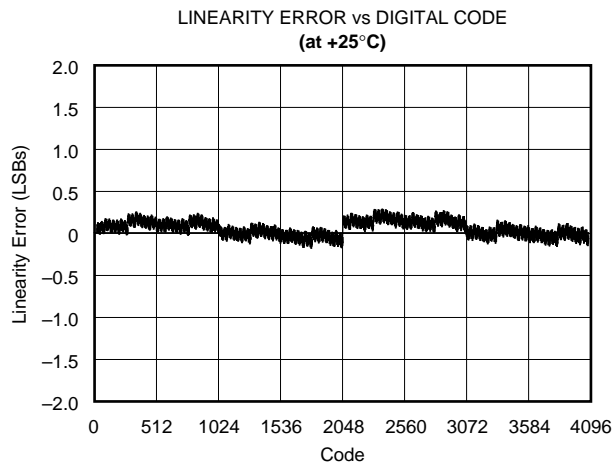

OPERATION

The DAC7621 is a 12-bit digital-to-analog converter (DAC) complete with an input shift register, DAC register, laser-trimmed 12-bit DAC, on-board reference, and a rail-to-rail output amplifier. Figure 1 shows the basic operation of the DAC7621.

INTERFACE

Figure 1 shows the basic connection between a microcontroller and the DAC7621. The interface consists of a Read/Write (R/W), data, and a load DAC signal (LOADDAC). In addition, a chip select (CS) input is available to enable the DAC7621 when there are multiple devices. The data format is Straight Binary. An asynchronous clear input (CLR) is provided to simplify start-up or periodic resets. Table I shows the relationship between input code and output voltage.

DAC7621 Full-Scale Range = 4.095V Least Significant Bit = 1mV		
DIGITAL INPUT CODE STRAIGHT OFFSET BINARY	ANALOG OUTPUT (V)	DESCRIPTION
FFF _H	+4.095	Full Scale
801 _H	+2.049	Midscale + 1 LSB
800 _H	+2.048	Midscale
7FF _H	+2.047	Midscale - 1 LSB
000 _H	0	Zero Scale

TABLE I. Digital Input Code and Corresponding Ideal Analog Output.

The digital data into the DAC7621 is double-buffered. This means that new data can be entered into the DAC without disturbing the old data and the analog output of the converter. At some point after the data has been entered into the serial shift register, this data can be transferred into the DAC register. This transfer is accomplished with a HIGH to LOW transition of the $\overline{\text{LOADDAC}}$ pin. However, the $\overline{\text{LOADDAC}}$ pin makes the DAC register transparent. If new data becomes available on the bus register while $\overline{\text{LOADDAC}}$ is LOW, the DAC output voltage will change as the data changes. To prevent this, $\overline{\text{CS}}$ must be returned HIGH prior to changing data on the bus.

At any time, the contents of the DAC register can be set to 000_H (analog output equals 0V) by taking the $\overline{\text{CLR}}$ input LOW. The DAC register will remain at this value until $\overline{\text{CLR}}$ is returned HIGH and $\overline{\text{LOADDAC}}$ is taken LOW to allow the contents of the input register to be transferred to the DAC register. If $\overline{\text{LOADDAC}}$ is LOW when $\overline{\text{CLR}}$ is taken LOW, the DAC register will be set to 000_H and the analog output driven to 0V. When $\overline{\text{CLR}}$ is returned HIGH, the DAC register and the analog output will respond accordingly.

DIGITAL-TO-ANALOG CONVERTER

The internal DAC section is a 12-bit voltage output device that swings between ground and the internal reference voltage. The DAC is realized by a laser-trimmed R-2R ladder network which is switched by N-channel MOSFETs. The DAC output is internally connected to the rail-to-rail output operational amplifier.

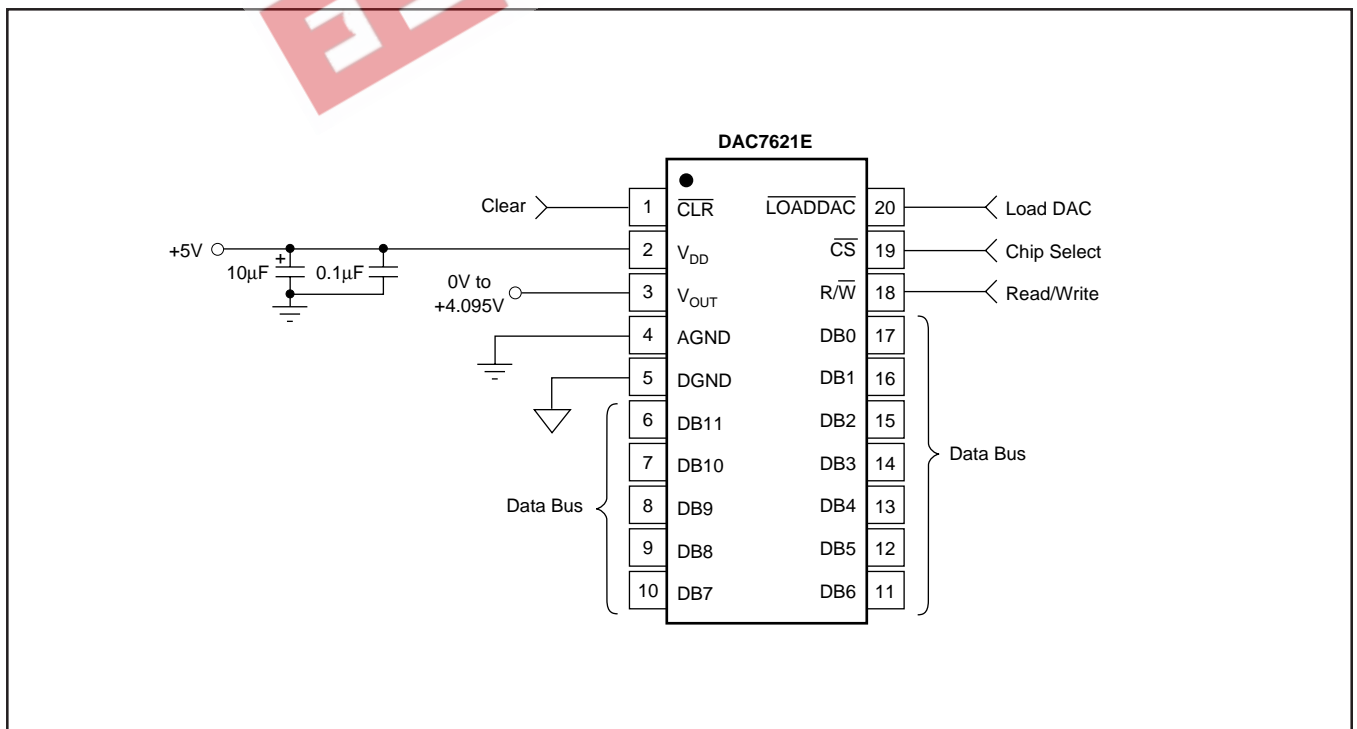

FIGURE 1. Basic Operation of the DAC7621.

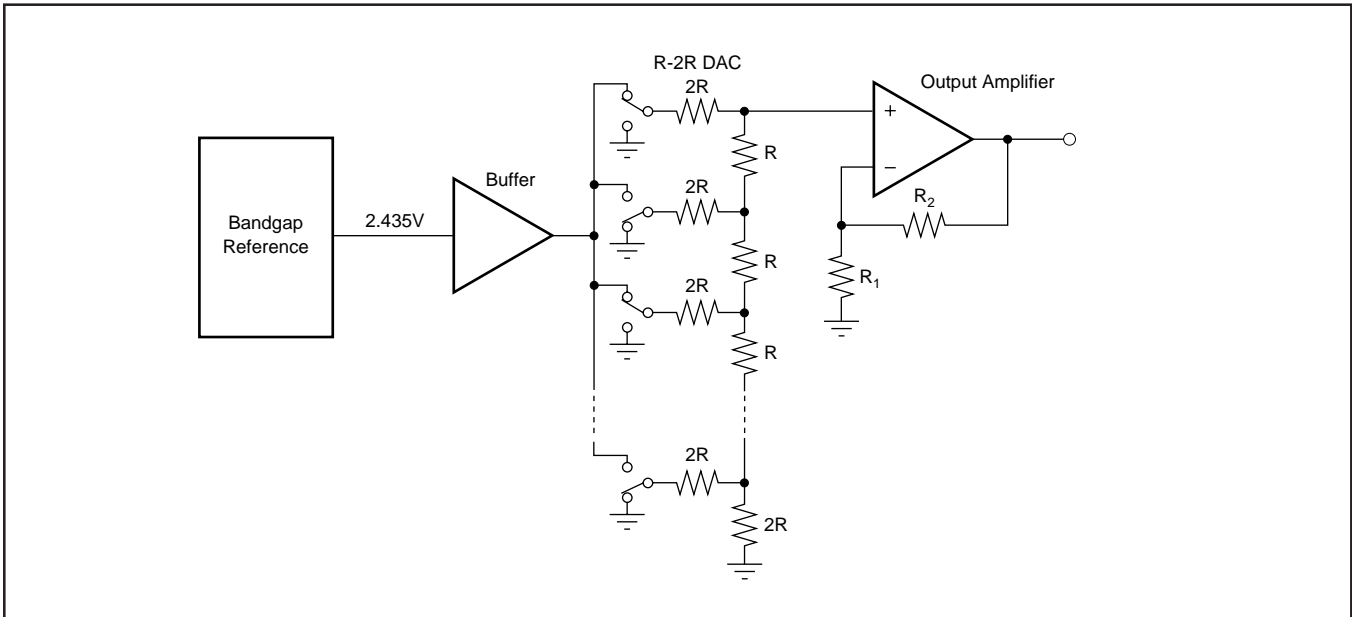

FIGURE 2. Simplified Schematic of Analog Portion.

OUTPUT AMPLIFIER

A precision, low-power amplifier buffers the output of the DAC section and provides additional gain to achieve a 0V to 4.095V range. The amplifier has low offset voltage, low noise, and a set gain of 1.682V/V (4.095/2.435). See Figure 2 for an equivalent circuit schematic of the analog portion of the DAC7621.

The output amplifier has a 7 μ s typical settling time to ± 1 LSB of the final value. Note that there are differences in the settling time for negative-going signals versus positive-going signals.

The rail-to-rail output stage of the amplifier provides the full-scale range of 0V to 4.095V while operating on a supply voltage as low as 4.75V. In addition to its ability to drive resistive loads, the amplifier will remain stable while driving capacitive loads of up to 500pF. See Figure 3 for an equivalent circuit schematic of the amplifier's output driver and the Typical Performance Curves section for more information regarding settling time, load driving capability, and output noise.

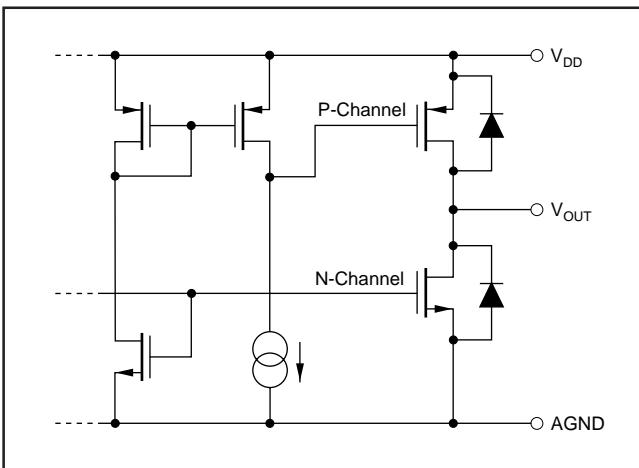

FIGURE 3. Simplified Driver Section of Output Amplifier.

POWER SUPPLY

A BiCMOS process and careful design of the bipolar and CMOS sections of the DAC7621 result in a very low power device. Bipolar transistors are used where tight matching and low noise are needed to achieve analog accuracy, and CMOS transistors are used for logic, switching functions and for other low power stages.

If power consumption is critical, it is important to keep the logic levels on the digital inputs (R/\bar{W} , CLK, \bar{CS} , $\bar{LOADDAC}$, CLR) as close as possible to either V_{DD} or ground. This will keep the CMOS inputs (see "Supply Current vs Logic Input Voltages" in the Typical Performance Curves) from shunting current between V_{DD} and ground.

The DAC7621 power supply should be bypassed as shown in Figure 1. The bypass capacitors should be placed as close to the device as possible, with the 0.1 μ F capacitor taking priority in this regard. The "Power Supply Rejection vs Frequency" graph in the Typical Performance Curves section shows the PSRR performance of the DAC7621. This should be taken into account when using switching power supplies or DC/DC converters.

In addition to offering guaranteed performance with V_{DD} in the 4.75V to 5.25V range, the DAC7621 will operate with reduced performance down to 4.5V. Operation between 4.5V and 4.75V will result in longer settling time, reduced performance, and current sourcing capability. Consult the " V_{DD} vs Load Current" graph in the Typical Performance Curves section for more information.

APPLICATIONS

POWER AND GROUNDING

The DAC7621 can be used in a wide variety of situations—from low power, battery operated systems to large-scale industrial process control systems. In addition, some applications require better performance than others, or are particularly sensitive to one or two specific parameters. This diversity makes it difficult to define definite rules to follow concerning the power supply, bypassing, and grounding. The following discussion must be considered in relation to the desired performance and needs of the particular system.

A precision analog component requires careful layout, adequate bypassing, and a clean, well-regulated power supply. As the DAC7621 is a single-supply, +5V component, it will often be used in conjunction with digital logic, microcontrollers, microprocessors, and digital signal processors. The more digital logic present in the design and the higher the switching speed, the more difficult it will be to achieve good performance.

The DAC7621 has separate analog ground and digital ground pins. The current through DGND is mostly switching transients and are up to 4mA peak in amplitude. The current through AGND is typically 0.5mA.

For best performance, separate analog and digital ground planes with a single interconnection point to minimize ground loops. The analog pins are located adjacent to each other to help isolate analog from digital signals. Analog signals should be routed as far as possible from digital

signals and should cross them at right angles. A solid analog ground plane around the D/A package, as well as under it in the vicinity of the analog and power supply pins, will isolate the D/A from switching currents. It is recommended that DGND and AGND be connected directly to the ground planes under the package.

If several DAC7621s are used, or if sharing supplies with other components, connecting the AGND and DGND lines together at the power supplies once, rather than at each chip, may produce better results.

The power applied to V_{DD} should be well regulated and low-noise. Switching power supplies and DC/DC converters will often have high-frequency glitches or spikes riding on the output voltage. In addition, digital components can create similar high frequency spikes as their internal logic switches states. This noise can easily couple into the DAC output voltage through various paths between V_{DD} and V_{OUT} .

As with the GND connection, V_{DD} should be connected to a +5V power supply plane or trace that is separate from the connection for digital logic until they are connected at the power entry point. In addition, the 10 μ F and 0.1 μ F capacitors shown in Figure 4 are strongly recommended and should be installed as close to V_{DD} and ground as possible. In some situations, additional bypassing may be required such as a 100 μ F electrolytic capacitor or even a “Pi” filter made up of inductors and capacitors—all designed to essentially lowpass filter the +5V supply, removing the high frequency noise (see Figure 4).

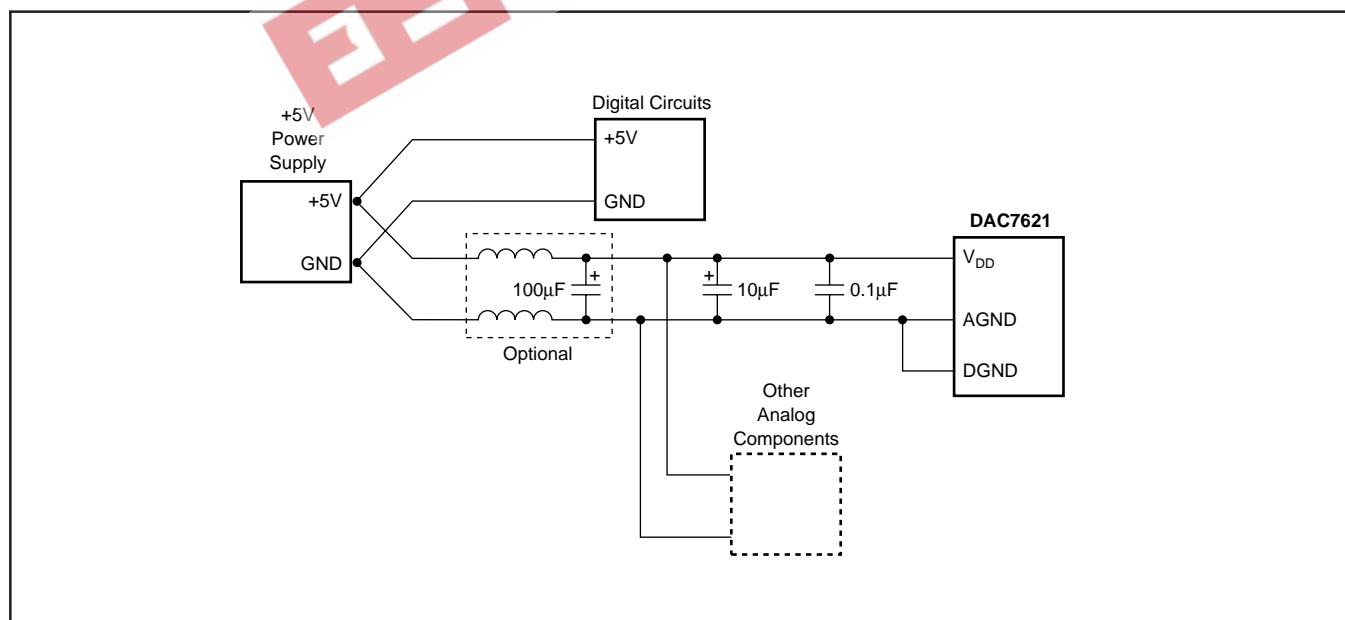

FIGURE 4. Suggested Power and Ground Connections for a DAC7621 Sharing a +5V Supply with a Digital System with a Single Ground Plane.