

FEATURES

- 180 - 2000 MHz
- High Density MIC
- 26 dB Gain
- Flatpack Case

HDI



MODEL NO.
DAD08059

L-Band / UHF Hybrid

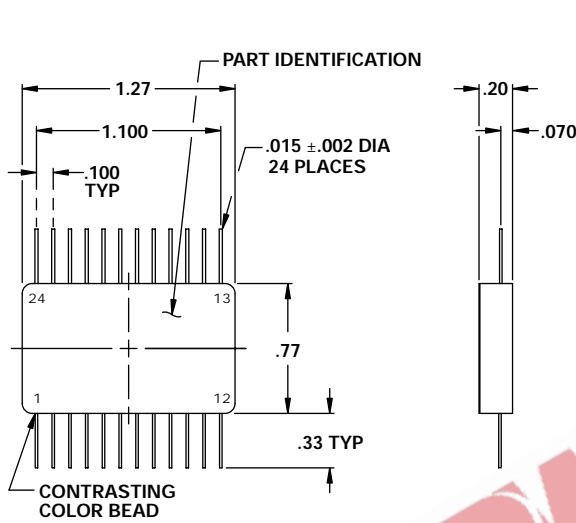

.xx = .02
.xxx = .010

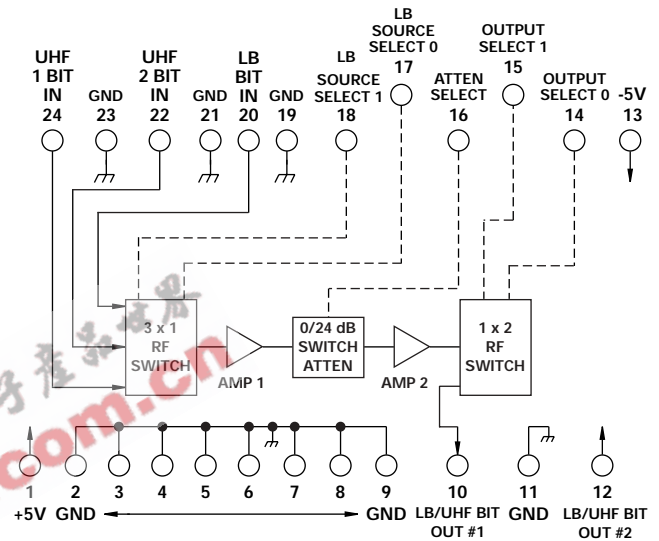

Source Select Control Logic		
Source Select 1	Source Select 0	Function
0	0	Off
0	1	L-Band Bit In
1	0	UHF 2 Bit In
1	1	UHF 1 Bit In

Output Select Control Logic		
Source Select 1	Source Select 0	Function
0	0	Off
0	1	Output #1 On
1	0	Output #2 On
1	1	Not Valid State

Switchable Attenuator Control Logic	
Source Select 1	Function
0	0 dB Selected
1	24 dB Selected

GUARANTEED PERFORMANCE

Parameter	Min	Typ	Max	Units	Conditions
Operating Frequency	180		2000	MHz	
DC Current		0.3	140	mA	At +5 VDC Supply At -5 VDC Supply
Control Type		TTL			Line
Control Current			±20	µA	V _{IH} = +2.7 V V _{IL} = +0.5 V
Gain	24.5		27.5	dB	Attenuator Disabled
Gain Variation with Temp	-1.5		+1.5		Attenuator Disabled
Switch Attenuation	23		25	dB	
Variation with Temperature	-1		+1		
Output Select RF Switch Isolation	45			dB	Between Any Selected Output and Other Non-Selected Output
Source Select RF Switch Isolation	40			dB	Between Any Selected Input and Other Non-Selected Inputs
VSWR			1.5/1		Input Selected or Not Selected Output Selected or Not Selected
Impedance		50		OHMS	
Switching Speed		30	100	nSec	50% TTL - 90% / 10% RF
Transition (Rise/Fall) Time		5		nSec	10% / 90% or 90% / 10% RF
Switching (Video) Transients		50		mV	Peak Value
Intercept Points		36		dBm	MHz
		23		dBm	MHz
RF Power	+10	+13		dBm	Attenuator Disabled
Operating Temperature	-55	+25	+70	°C	TA