

Features

- Epitaxial Planar Die Construction
- Complementary PNP Types Available (DDTB)
- Built-In Biasing Resistors
- Lead Free Product

Mechanical Data

- Case: SOT-323, Molded Plastic
- Case material - UL Flammability Rating 94V-0
- Moisture sensitivity: Level 1 per J-STD-020A
- Terminals: Finish - Matte Tin (Note 1)
Solderable per MIL-STD-202, Method 208
- Terminal Connections: See Diagram
- Marking: Date Code and Marking Code
(See Diagrams & Page 2)
- Weight: 0.006 grams (approx.)
- Ordering Information (See Page 2)

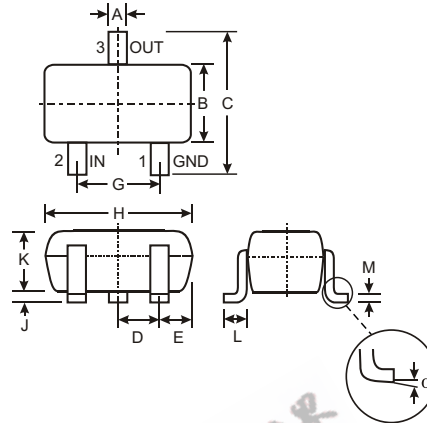

SOT-323		
Dim	Min	Max
A	0.25	0.40
B	1.15	1.35
C	2.00	2.20
D	0.65 Nominal	
E	0.30	0.40
G	1.20	1.40
H	1.80	2.20
J	0.0	0.10
K	0.90	1.00
L	0.25	0.40
M	0.10	0.18
α	0°	8°
All Dimensions in mm		

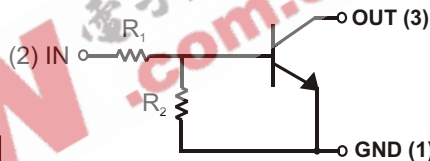

P/N	R1 (NOM)	R2 (NOM)	MARKING
DDTD122LU	0.22KΩ	10KΩ	N75
DDTD142JU	0.47KΩ	10KΩ	N76
DDTD122TU	0.22KΩ	OPEN	N77
DDTD142TU	0.47KΩ	OPEN	N78

Maximum Ratings @ T_A = 25°C unless otherwise specified

Characteristic	Symbol	Value	Unit
Supply Voltage, (3) to (1)	V _{CC}	50	V
Input Voltage, (2) to (1)	V _{IN}	-5 to +6	V
Input Voltage, (1) to (2)	V _{EBO (MAX)}	5	V
Output Current	I _C	500	mA
Power Dissipation (Note 2)	P _d	200	mW
Thermal Resistance, Junction to Ambient Air (Note 2)	R _{θJA}	625	°C/W
Operating and Storage and Temperature Range	T _J , T _{STG}	-55 to +150	°C

- Note: 1. If lead-bearing terminal plating is required, please contact your Diodes Inc. sales representative for availability and minimum order details.
2. Mounted on FR4 PC Board with recommended pad layout at <http://www.diodes.com/datasheets/ap02001.pdf>.

Electrical Characteristics @ T_A = 25°C unless otherwise specified

R1, R2 Types

Characteristic		Symbol	Min	Typ	Max	Unit	Test Condition
Input Voltage	DDTD122LU DDTD142JU	V _{I(off)}	0.3 0.3	—	—	V	V _{CC} = 5V, I _O = 100μA
	DDTD122LU DDTD142JU	V _{I(on)}	—	—	2.0 2.0	V	V _O = 0.3V, I _O = 20mA V _O = 0.3V, I _O = 20mA
Output Voltage		V _{O(on)}	—	—	0.3V	V	I _O /I _I = 50mA/2.5mA
Input Current	DDTD122LU DDTD142JU	I _I	—	—	28 13	mA	V _I = 5V
Output Current		I _{O(off)}	—	—	0.5	μA	V _{CC} = 50V, V _I = 0V
DC Current Gain	DDTD122LU DDTD142JU	G _I	56 56	—	—	—	V _O = 5V, I _O = 50mA
Gain-Bandwidth Product*		f _T	—	200	—	MHz	V _{CE} = 10V, I _E = 5mA, f = 100MHz

* Transistor - For Reference Only

Electrical Characteristics @ T_A = 25°C unless otherwise specified

R1-Only, R2-Only Types

Characteristic		Symbol	Min	Typ	Max	Unit	Test Condition
Collector-Base Breakdown Voltage		BV _{CBO}	50	—	—	V	I _C = 50μA
Collector-Emitter Breakdown Voltage		BV _{CEO}	40	—	—	V	I _C = 1mA
Emitter-Base Breakdown Voltage	DDTD122TU DDTD142TU	BV _{EBO}	5	—	—	V	I _E = 50μA I _E = 50μA
Collector Cutoff Current		I _{CBO}	—	—	0.5	μA	V _{CB} = 50V
Emitter Cutoff Current	DDTD122TU DDTD142TU	I _{EBO}	—	—	0.5 0.5	μA	V _{EB} = 4V
Collector-Emitter Saturation Voltage		V _{CE(sat)}	—	—	0.3	V	I _C = 50mA, I _B = 2.5mA
DC Current Transfer Ratio	DDTD122TU DDTD142TU	h _{FE}	100 100	250 250	600 600	—	I _C = 5mA, V _{CE} = 5V
Gain-Bandwidth Product*		f _T	—	200	—	MHz	V _{CE} = 10V, I _E = -5mA, f = 100MHz

* Transistor - For Reference Only

Ordering Information (Note 2)

Device	Packaging	Shipping
DDTD122LU-7	SOT-323	3000/Tape & Reel
DDTD142JU-7	SOT-323	3000/Tape & Reel
DDTD122TU-7	SOT-323	3000/Tape & Reel
DDTD142TU-7	SOT-323	3000/Tape & Reel

Notes: 1. If lead-bearing terminal plating is required, please contact your Diodes Inc. sales representative for availability and minimum order details.
3. For Packaging Details, go to our website at <http://www.diodes.com/datasheets/ap02007.pdf>.

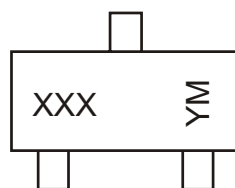
Marking Information

XXX = Product Type Marking Code
See Sheet 1 Diagrams
YM = Date Code Marking
Y = Year ex: P = 2003
M = Month ex: 9 = September

Date Code Key

Year	2002	2003	2004	2005	2006	2007	2008	2009
Code	N	P	R	S	T	U	V	W

Month	Jan	Feb	March	Apr	May	Jun	Jul	Aug	Sep	Oct	Nov	Dec
Code	1	2	3	4	5	6	7	8	9	O	N	D

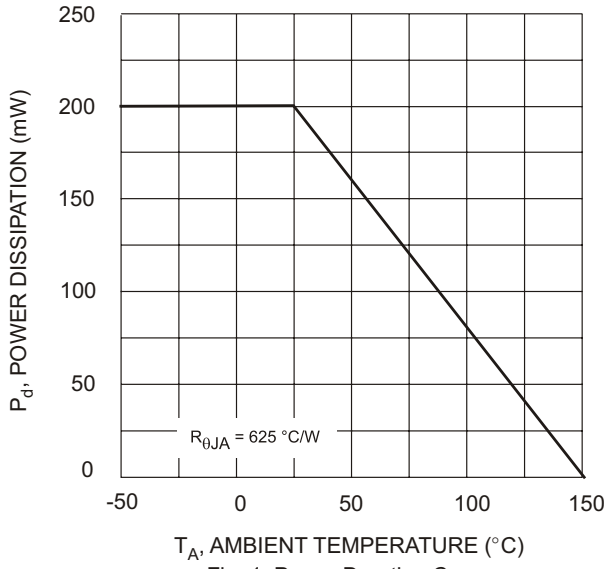

Fig. 1 Power Derating Curve

EEPW 电子产品世界 .com.cn