

## Features

- Epitaxial Planar Die Construction
- Complementary NPN Types Available (DDTD)
- Built-In Biasing Resistors
- Lead Free Product

## Mechanical Data

- Case: SOT-23, Molded Plastic
- Case material - UL Flammability Rating 94V-0
- Moisture sensitivity: Level 1 per J-STD-020A
- Terminals: Finish - Matte Tin (Note 1)  
Solderable per MIL-STD-202, Method 208
- Terminal Connections: See Diagram
- Marking: Date Code and Marking Code (See Diagrams & Page 2)
- Weight: 0.008 grams (approx.)
- Ordering Information (See Page 2)

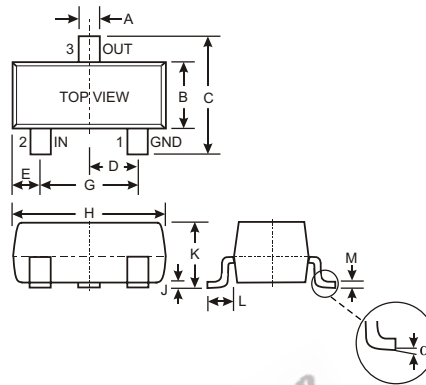

SOT-23		
Dim	Min	Max
A	0.37	0.51
B	1.20	1.40
C	2.30	2.50
D	0.89	1.03
E	0.45	0.60
G	1.78	2.05
H	2.80	3.00
J	0.013	0.10
K	0.903	1.10
L	0.45	0.61
M	0.085	0.180
$\alpha$	0°	8°
All Dimensions in mm		

P/N	R1 (NOM)	R2 (NOM)	MARKING
DDTB122LC	0.22K $\Omega$	10K $\Omega$	P75
DDTB142JC	0.47K $\Omega$	10K $\Omega$	P76
DDTB122TC	0.22K $\Omega$	OPEN	P77
DDTB142TC	0.47K $\Omega$	OPEN	P78

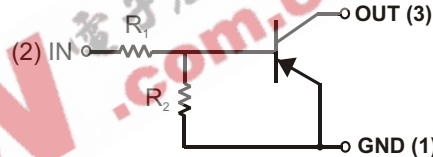

## Maximum Ratings @ T<sub>A</sub> = 25°C unless otherwise specified

Characteristic	Symbol	Value	Unit
Supply Voltage, (3) to (1)	V <sub>CC</sub>	-50	V
Input Voltage, (2) to (1)	V <sub>IN</sub>	+5 to -6 +5 to -6	V
Input Voltage, (1) to (2)	V <sub>EBO (MAX)</sub>	-5	V
Output Current	I <sub>C</sub>	-500	mA
Power Dissipation (Note 2)	P <sub>d</sub>	200	mW
Thermal Resistance, Junction to Ambient Air (Note 2)	R <sub>θJA</sub>	625	°C/W
Operating and Storage and Temperature Range	T <sub>J</sub> , T <sub>STG</sub>	-55 to +150	°C

- Note: 1. If lead-bearing terminal plating is required, please contact your Diodes Inc. sales representative for availability and minimum order details.  
2. Mounted on FR4 PC Board with recommended pad layout at <http://www.diodes.com/datasheets/ap02001.pdf>.

**Electrical Characteristics** @ T<sub>A</sub> = 25°C unless otherwise specified

**R1, R2 Types**

Characteristic	Symbol	Min	Typ	Max	Unit	Test Condition	
Input Voltage	DDTB122LC DDTB142JC	V <sub>I(off)</sub>	-0.3	—	—	V	V <sub>CC</sub> = -5V, I <sub>O</sub> = -100μA
	DDTB122LC DDTB142JC	V <sub>I(on)</sub>	—	—	-2.0 -2.0	V	V <sub>O</sub> = -0.3V, I <sub>O</sub> = -20mA V <sub>O</sub> = -0.3V, I <sub>O</sub> = -20mA
Output Voltage		V <sub>O(on)</sub>	—	—	-0.3V	V	I <sub>O</sub> /I <sub>I</sub> = -50mA/-2.5mA
Input Current	DDTB122LC DDTB142JC	I <sub>I</sub>	—	—	-28 -13	mA	V <sub>I</sub> = -5V
Output Current		I <sub>O(off)</sub>	—	—	-0.5	μA	V <sub>CC</sub> = -50V, V <sub>I</sub> = 0V
DC Current Gain	DDTB122LC DDTB142JC	G <sub>I</sub>	56 56	—	—	—	V <sub>O</sub> = -5V, I <sub>O</sub> = -50mA
Gain-Bandwidth Product*		f <sub>T</sub>	—	200	—	MHz	V <sub>CE</sub> = -10V, I <sub>E</sub> = -5mA, f = 100MHz

\* Transistor - For Reference Only

**Electrical Characteristics** @ T<sub>A</sub> = 25°C unless otherwise specified

**R1-Only Types**

Characteristic	Symbol	Min	Typ	Max	Unit	Test Condition	
Collector-Base Breakdown Voltage	BV <sub>CBO</sub>	-50	—	—	V	I <sub>C</sub> = -50μA	
Collector-Emitter Breakdown Voltage	BV <sub>CEO</sub>	-40	—	—	V	I <sub>C</sub> = -1mA	
Emitter-Base Breakdown Voltage	DDTB122TC DDTB142TC	BV <sub>EBO</sub>	-5	—	V	I <sub>E</sub> = -50μA I <sub>E</sub> = -50μA	
Collector Cutoff Current	I <sub>CBO</sub>	—	—	-0.5	μA	V <sub>CB</sub> = -50V	
Emitter Cutoff Current	DDTB122TC DDTB142TC	I <sub>EBO</sub>	—	-0.5 -0.5	μA	V <sub>EB</sub> = -4V	
Collector-Emitter Saturation Voltage	V <sub>CE(sat)</sub>	—	—	-0.3	V	I <sub>C</sub> = -50mA, I <sub>B</sub> = -2.5mA	
DC Current Transfer Ratio	DDTB122TC DDTB142TC	h <sub>FE</sub>	100 100	250 250	600 600	—	I <sub>C</sub> = -5mA, V <sub>CE</sub> = -5V
Gain-Bandwidth Product*		f <sub>T</sub>	—	200	—	MHz	V <sub>CE</sub> = -10V, I <sub>E</sub> = 5mA, f = 100MHz

\* Transistor - For Reference Only

**Ordering Information** (Note 3)

Device	Packaging	Shipping
DDTB122LC-7	SOT-23	3000/Tape & Reel
DDTB142JC-7	SOT-23	3000/Tape & Reel
DDTB122TC-7	SOT-23	3000/Tape & Reel
DDTB142TC-7	SOT-23	3000/Tape & Reel

- Notes: 1. If lead-bearing terminal plating is required, please contact your Diodes Inc. sales representative for availability and minimum order details.  
3. For Packaging Details, go to our website at <http://www.diodes.com/datasheets/ap02007.pdf>.

**Marking Information**

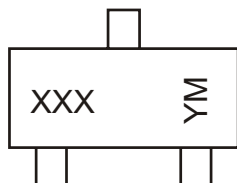

XXX = Product Type Marking Code  
See Sheet 1 Diagrams  
YM = Date Code Marking  
Y = Year ex: P = 2003  
M = Month ex: 9 = September

Date Code Key

Year	2002	2003	2004	2005	2006	2007	2008	2009
Code	N	P	R	S	T	U	V	W

Month	Jan	Feb	March	Apr	May	Jun	Jul	Aug	Sep	Oct	Nov	Dec
Code	1	2	3	4	5	6	7	8	9	O	N	D

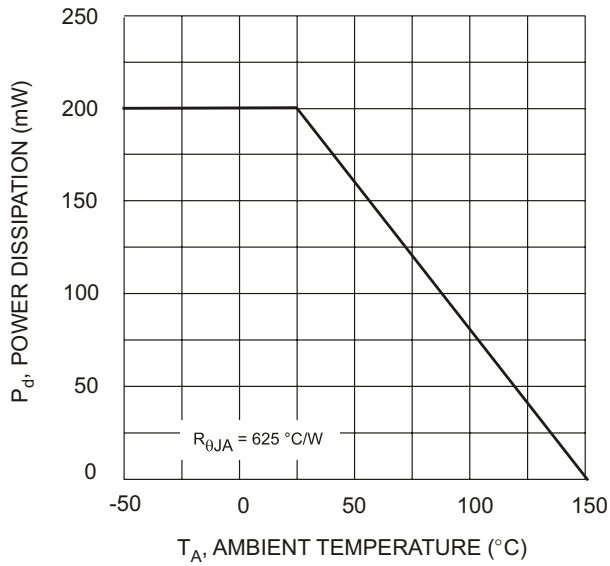

Fig. 1 Power Derating Curve

EEPW 电子产品世界 .com.cn