



**MODEL NUMBER
DAD02006**

Analog Level Detector

FEATURES

- 500-2000 MHz
- ± 0.4 dB Temperature Stability
- 185 mV Output Voltage @ $P_{in} = -10$ dBm
- ± 1 dB Input Flatness
- Broad Temperature Range
- 5 Pin TO-8 Package
- -20 to +10 dBm Dynamic Range

TD

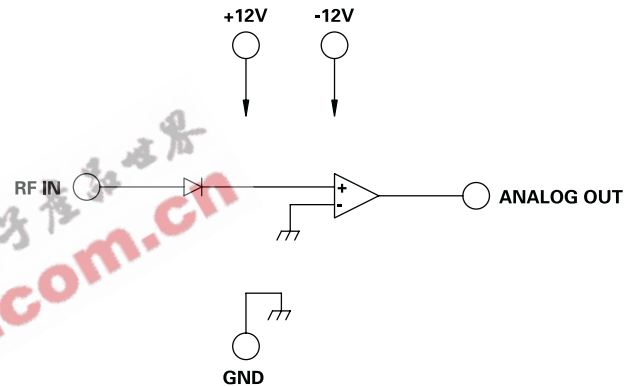
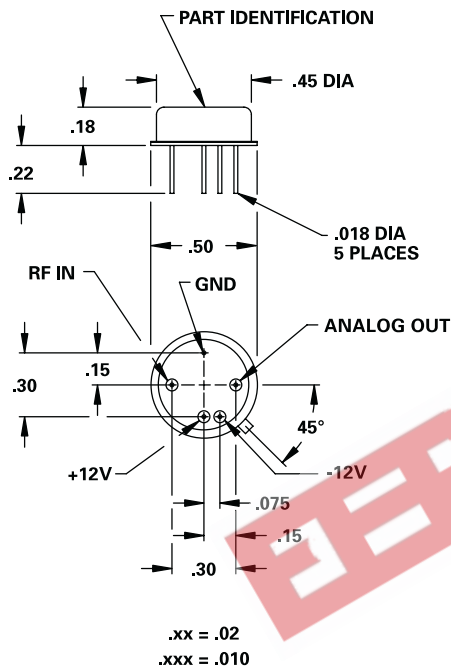

GUARANTEED PERFORMANCE

Parameter	Min	Typ	Max	Units	Conditions
Operating Frequency	500		2000	MHz	
Dynamic Range	-20		+10	dBm	
Temperature Stability		± 0.4	± 1.0	dB	+10 to -10 dBm
Input Flatness		± 0.4	± 1.0	dB	+10 to -10 dBm
Analog Output		835		mV	$P_{in} = 0$ dBm
		410		mV	$P_{in} = -5$ dBm
		185		mV	$P_{in} = -10$ dBm
Rise Time		12	20	μ Sec	10% / 90%
Input VSWR		1.4/1	1.7/1		
Output Offset Drift		50		mV	No Input Power Over Temp.
DC Current		1.4	2	mA	At +12 VDC
		1.5	2	mA	At -12 VDC
Operating Temperature	-55	+25	+110	$^{\circ}$ C	TA

**TYPICAL PERFORMANCE
at 25 $^{\circ}$ C**

