

Features

- Epitaxial Planar Die Construction
- Complementary PNP Types Available (DDTA)
- Built-In Biasing Resistors
- **Lead Free/RoHS Compliant (Note 2)**

Mechanical Data

- Case: SOT-523
- Case Material: Molded Plastic. UL Flammability Classification Rating 94V-0
- Moisture sensitivity: Level 1 per J-STD-020C
- Terminals: Finish - Solderable per MIL-STD-202, Method 208
- Lead Free Plating (Matte Tin Finish annealed over Alloy 42 leadframe)
- Terminal Connections: See Diagram
- Marking: Date Code and Marking Code (See Diagrams & Page 2)
- Weight: 0.002 grams (approximate)
- Ordering Information (See Page 2)

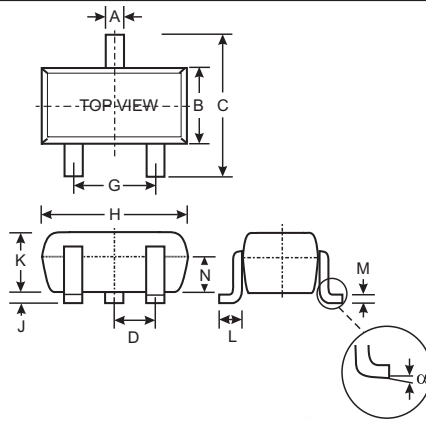

SOT-523			
Dim	Min	Max	Typ
A	0.15	0.30	0.22
B	0.75	0.85	0.80
C	1.45	1.75	1.60
D	—	—	0.50
G	0.90	1.10	1.00
H	1.50	1.70	1.60
J	0.00	0.10	0.05
K	0.60	0.80	0.75
L	0.10	0.30	0.22
M	0.10	0.20	0.12
N	0.45	0.65	0.50
α	0°	8°	—
All Dimensions in mm			

P/N	R1 (NOM)	R2 (NOM)	MARKING
DDTC122LE	0.22K Ω	10K Ω	N81
DDTC142JE	0.47K Ω	10K Ω	N82
DDTC122TE	0.22K Ω	OPEN	N83
DDTC142TE	0.47K Ω	OPEN	N84

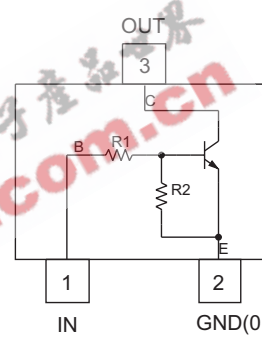

Schematic and Pin Configuration

Maximum Ratings @ T_A = 25°C unless otherwise specified

Characteristic	Symbol	Value	Unit
Supply Voltage, (3) to (2)	V _{CC}	50	V
Input Voltage, (1) to (2)	V _{IN}	-5 to +6	V
Input Voltage, (2) to (1)	V _{EBO (MAX)}	5	V
Output Current	I _C	100	mA
Power Dissipation (Note 1)	P _d	150	mW
Thermal Resistance, Junction to Ambient Air (Note 1)	R _{θJA}	625	°C/W
Operating and Storage and Temperature Range	T _j , T _{STG}	-55 to +150	°C

Note: 1. Mounted on FR4 PC Board with recommended pad layout at <http://www.diodes.com/datasheets/ap02001.pdf>.
2. No purposefully added lead.

Electrical Characteristics @ T_A = 25°C unless otherwise specified

R1, R2 Types

Characteristic		Symbol	Min	Typ	Max	Unit	Test Condition
Input Voltage	DDTC122LE DDTC142JE	V _{I(off)}	0.3 0.3	—	—	V	V _{CC} = 5V, I _O = 100μA
	DDTC122LE DDTC142JE	V _{I(on)}	—	—	2.0 2.0	V	V _O = 0.3V, I _O = 20mA V _O = 0.3V, I _O = 20mA
Output Voltage		V _{O(on)}	—	—	0.3V	V	I _O /I _I = 5mA/0.25mA
Input Current	DDTC122LE DDTC142JE	I _I	—	—	28 13	mA	V _I = 5V
Output Current		I _{O(off)}	—	—	0.5	μA	V _{CC} = 50V, V _I = 0V
DC Current Gain	DDTC122LE DDTC142JE	G _I	56 56	—	—	—	V _O = 5V, I _O = 10mA
Gain-Bandwidth Product*		f _T	—	200	—	MHz	V _{CE} = 10V, I _E = 5mA, f = 100MHz

* Transistor - For Reference Only

Electrical Characteristics @ T_A = 25°C unless otherwise specified

R1-Only

Characteristic		Symbol	Min	Typ	Max	Unit	Test Condition
Collector-Base Breakdown Voltage		BV _{CBO}	50	—	—	V	I _C = 50μA
Collector-Emitter Breakdown Voltage		BV _{CEO}	40	—	—	V	I _C = 1mA
Emitter-Base Breakdown Voltage	DDTC122TE DDTC142TE	BV _{EBO}	5	—	—	V	I _E = 50μA I _E = 50μA
Collector Cutoff Current		I _{CBO}	—	—	0.5	μA	V _{CB} = 50V
Emitter Cutoff Current	DDTC122TE DDTC142TE	I _{EBO}	—	—	0.5 0.5	μA	V _{EB} = 4V
Collector-Emitter Saturation Voltage		V _{CE(sat)}	—	—	0.3	V	I _C = 5mA, I _B = 0.25mA
DC Current Transfer Ratio	DDTC122TE DDTC142TE	h _{FE}	100 100	250 250	600 600	—	I _C = 1mA, V _{CE} = 5V
Gain-Bandwidth Product*		f _T	—	200	—	MHz	V _{CE} = 10V, I _E = -5mA, f = 100MHz

* Transistor - For Reference Only

Ordering Information (Note 3)

Device	Packaging	Shipping
DDTC122LE-7-F	SOT-523	3000/Tape & Reel
DDTC142JE-7-F	SOT-523	3000/Tape & Reel
DDTC122TE-7-F	SOT-523	3000/Tape & Reel
DDTC142TE-7-F	SOT-523	3000/Tape & Reel

Notes: 3. For Packaging Details, go to our website at <http://www.diodes.com/datasheets/ap02007.pdf>.

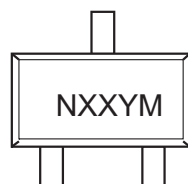
Marking Information

NXX = Product Type Marking Code (See Page 1)
 YM = Date Code Marking
 Y = Year ex: T = 2006
 M = Month ex: 9 = September

Date Code Key

Year	2002	2003	2004	2005	2006	2007	2008	2009	2010	2011	2012
Code	N	P	R	S	T	U	V	W	X	Y	Z

Month	Jan	Feb	Mar	Apr	May	Jun	Jul	Aug	Sep	Oct	Nov	Dec
Code	1	2	3	4	5	6	7	8	9	O	N	D

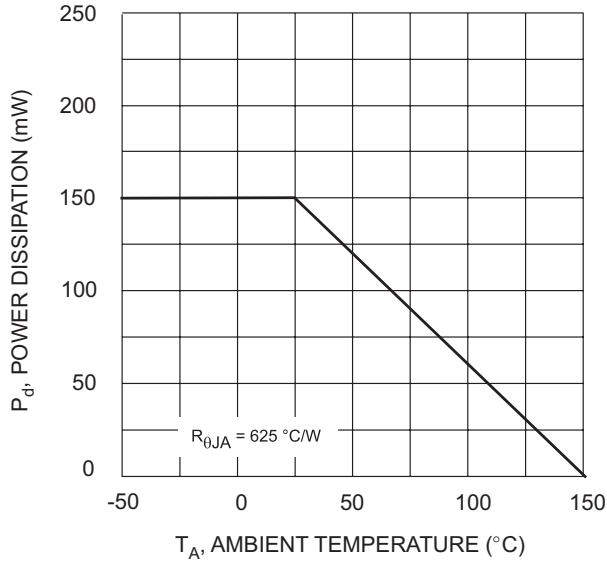

Fig. 1 Power Derating Curve

IMPORTANT NOTICE

Diodes Incorporated and its subsidiaries reserve the right to make modifications, enhancements, improvements, corrections or other changes without further notice to any product herein. Diodes Incorporated does not assume any liability arising out of the application or use of any product described herein; neither does it convey any license under its patent rights, nor the rights of others. The user of products in such applications shall assume all risks of such use and will agree to hold Diodes Incorporated and all the companies whose products are represented on our website, harmless against all damages.

LIFE SUPPORT

Diodes Incorporated products are not authorized for use as critical components in life support devices or systems without the expressed written approval of the President of Diodes Incorporated.