

## Features

- Epitaxial Planar Die Construction
- Complementary PNP Types Available (DDTA)
- Built-In Biasing Resistor, R1 only

## Mechanical Data

- Case: SOT-323, Molded Plastic
- Case Material - UL Flammability Rating 94V-0
- Moisture sensitivity: Level 1 per J-STD-020A
- Terminals: Solderable per MIL-STD-202, Method 208
- Terminal Connections: See Diagram
- Marking: Date Code and Marking Code (See Diagrams & Page 2)
- Weight: 0.006 grams (approx.)
- Ordering Information (See Page 2)

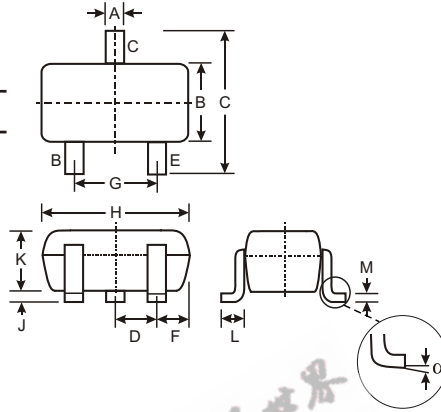

SOT-323		
Dim	Min	Max
A	0.25	0.40
B	1.15	1.35
C	2.00	2.20
D	0.65 Nominal	
E	0.30	0.40
G	1.20	1.40
H	1.80	2.20
J	0.0	0.10
K	0.90	1.00
L	0.25	0.40
M	0.10	0.18
	0	8

All Dimensions in mm

P/N	R1 (NOM)	MARKING
DDTC113TUA	1K	N01
DDTC123TUA	2.2K	N03
DDTC143TUA	4.7K	N07
DDTC114TUA	10K	N12
DDTC124TUA	22K	N16
DDTC144TUA	47K	N19
DDTC115TUA	100K	N23
DDTC125TUA	200K	N25

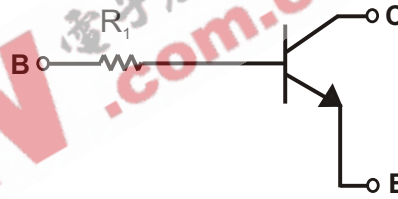

SCHMATIC DIAGRAM

## Maximum Ratings @ T<sub>A</sub> = 25 C unless otherwise specified

Characteristic	Symbol	Value	Unit
Collector-Base Voltage	V <sub>CBO</sub>	50	V
Collector-Emitter Voltage	V <sub>CEO</sub>	50	V
Emitter-Base Voltage	V <sub>EBO</sub>	5	V
Collector Current	I <sub>C</sub> (Max)	100	mA
Power Dissipation	P <sub>d</sub>	200	mW
Thermal Resistance, Junction to Ambient Air (Note 1)	R <sub>JA</sub>	833	C/W
Operating and Storage and Temperature Range	T <sub>J</sub> , T <sub>STG</sub>	-55 to +150	C

Note: 1. Mounted on FR4 PC Board with recommended pad layout at <http://www.diodes.com/datasheets/ap02001.pdf>.

## Electrical Characteristics @ T<sub>A</sub> = 25 C unless otherwise specified

Characteristic	Symbol	Min	Typ	Max	Unit	Test Condition
Collector-Base Breakdown Voltage	BV <sub>CBO</sub>	50			V	I <sub>C</sub> = 50 A
Collector-Emitter Breakdown Voltage	BV <sub>CEO</sub>	50			V	I <sub>C</sub> = 1mA
Emitter-Base Breakdown Voltage	BV <sub>EBO</sub>	5			V	I <sub>E</sub> = 50 A
Collector Cutoff Current	I <sub>CBO</sub>			0.5	A	V <sub>CB</sub> = 50V
Emitter Cutoff Current	I <sub>EBO</sub>			0.5	A	V <sub>EB</sub> = 4V
Collector-Emitter Saturation Voltage	V <sub>CE(sat)</sub>			0.3	V	I <sub>C</sub> /I <sub>B</sub> = 10mA/1mA DDTC113TUA I <sub>C</sub> /I <sub>B</sub> = 5mA/0.5mA DDTC123TUA I <sub>C</sub> /I <sub>B</sub> = 2.5mA/.25mA DDTC143TUA I <sub>C</sub> /I <sub>B</sub> = 1mA/.1mA DDTC114TUA I <sub>C</sub> /I <sub>B</sub> = 5mA/0.5mA DDTC124TUA I <sub>C</sub> /I <sub>B</sub> = 2.5mA/.25mA DDTC144TUA I <sub>C</sub> /I <sub>B</sub> = 1mA/0.1mA DDTC115TUA I <sub>C</sub> /I <sub>B</sub> = .5mA/.05mA DDTC125TUA
DC Current Transfer Ratio	h <sub>FE</sub>	100	250	600		I <sub>C</sub> = 1mA, V <sub>CE</sub> = 5V
Input Resistor (R <sub>1</sub> ) Tolerance	DR <sub>1</sub>	-30		+30	%	
Gain-Bandwidth Product*	f <sub>T</sub>		250		MHz	V <sub>CE</sub> = 10V, I <sub>E</sub> = -5mA, f = 100MHz

\* Transistor - For Reference Only

## Ordering Information (Note 2)

Device	Packaging	Shipping
DDTC113TUA-7	SOT-323	3000/Tape & Reel
DDTC123TUA-7	SOT-323	3000/Tape & Reel
DDTC143TUA-7	SOT-323	3000/Tape & Reel
DDTC114TUA-7	SOT-323	3000/Tape & Reel
DDTC124TUA-7	SOT-323	3000/Tape & Reel
DDTC144TUA-7	SOT-323	3000/Tape & Reel
DDTC115TUA-7	SOT-323	3000/Tape & Reel
DDTC125TUA-7	SOT-323	3000/Tape & Reel

Notes: 2. For Packaging Details, go to our website at <http://www.diodes.com/datasheets/ap02007.pdf>.

## Marking Information

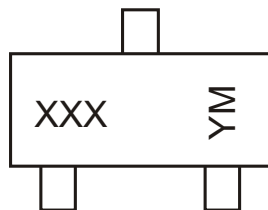

XXX = Product Type Marking Code  
 See Sheet 1 Diagrams  
 YM = Date Code Marking  
 Y = Year ex: N = 2002  
 M = Month ex: 9 = September

Date Code Key

Year	2002	2003	2004	2005	2006	2007	2008	2009
Code	N	P	R	S	T	U	V	W

Month	Jan	Feb	March	Apr	May	Jun	Jul	Aug	Sep	Oct	Nov	Dec
Code	1	2	3	4	5	6	7	8	9	O	N	D

# TYPICAL CURVES - DDTC114TUA

NEW PRODUCT

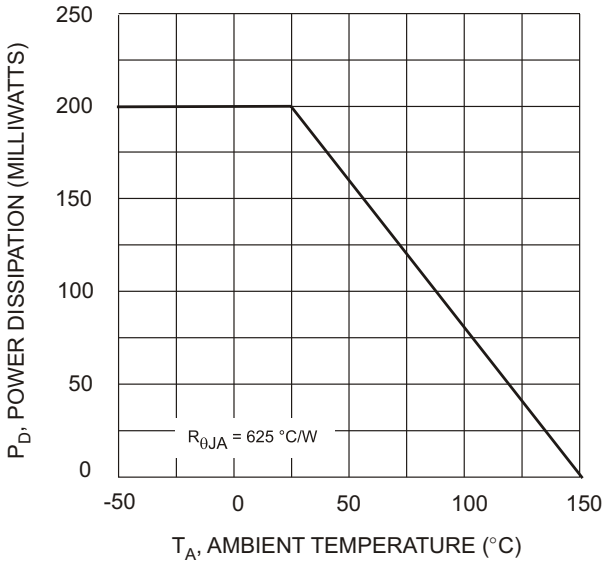

Fig. 1 Derating Curve

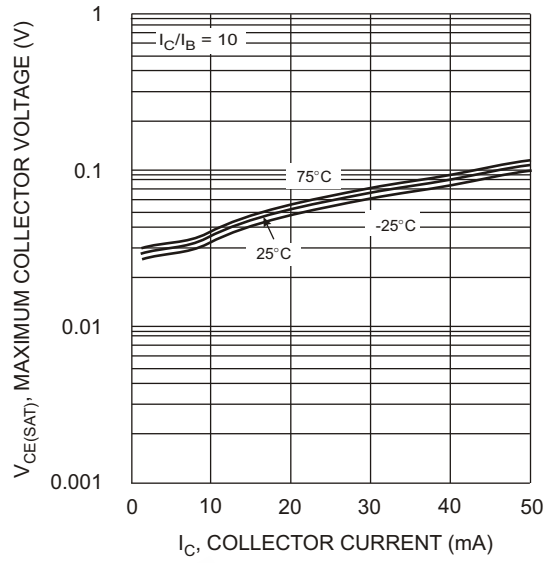

Fig. 2  $V_{CE(SAT)}$  vs.  $I_C$

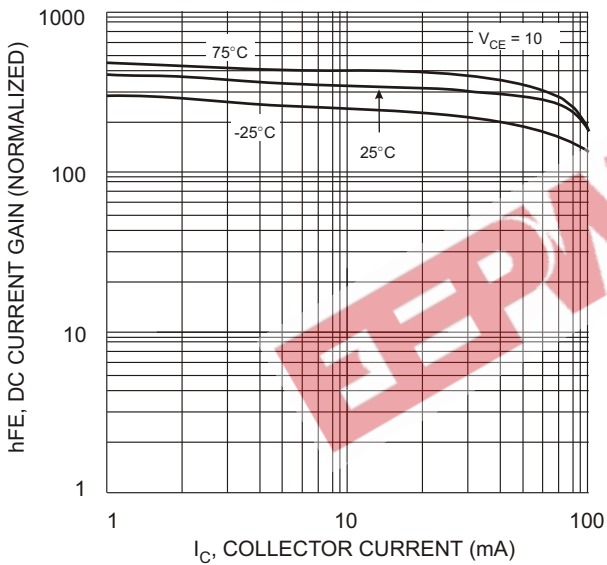

Fig. 3 DC Current Gain

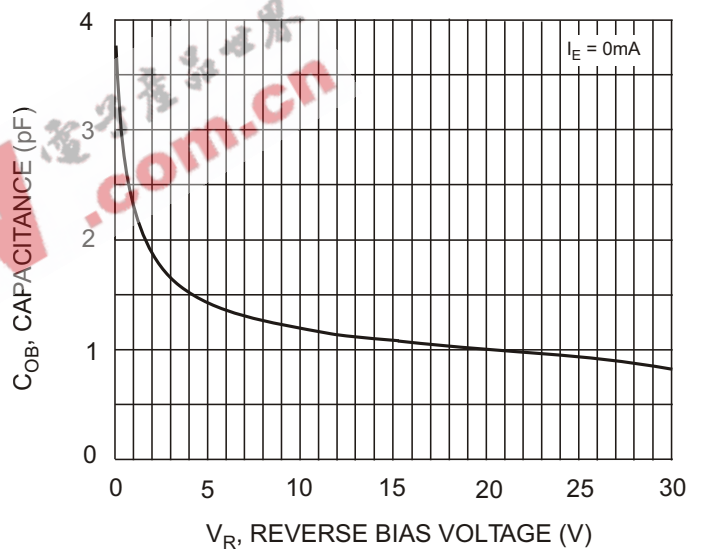

Fig. 4 Output Capacitance

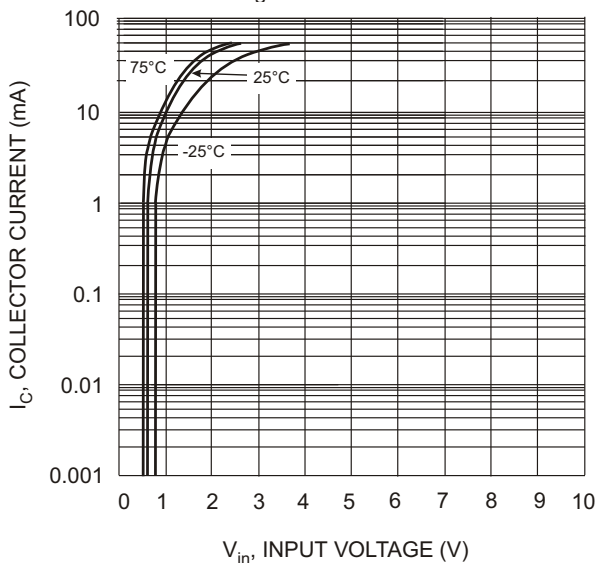

Fig. 5 Collector Current Vs. Input Voltage

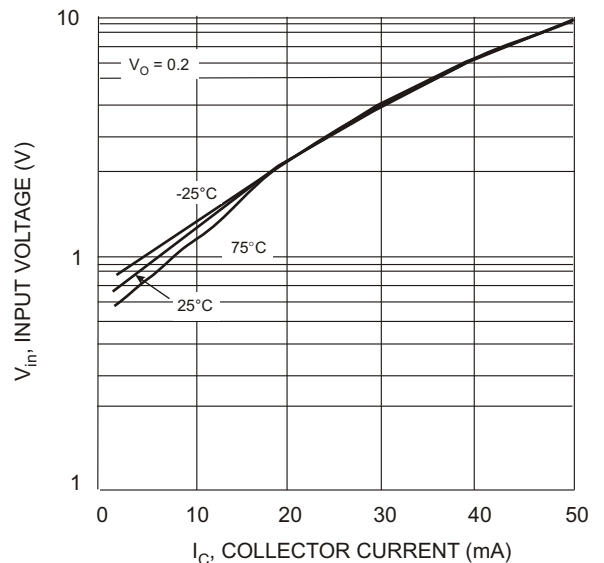

Fig. 6 Input Voltage vs. Collector Current