



DC COMPONENTS CO., LTD.
DISCRETE SEMICONDUCTORS

DC8050S

TECHNICAL SPECIFICATIONS OF NPN EPITAXIAL PLANAR TRANSISTOR

Description

Designed for general purpose amplifier applications.

Pinning

- 1 = Emitter
- 2 = Base
- 3 = Collector

Absolute Maximum Ratings (T_A=25°C)

Characteristic	Symbol	Rating	Unit
Collector-Base Voltage	V _{CB0}	25	V
Collector-Emitter Voltage	V _{CEO}	20	V
Emitter-Base Voltage	V _{EBO}	5	V
Collector Current	I _C	700	mA
Total Power Dissipation	P _D	625	mW
Junction Temperature	T _J	+150	°C
Storage Temperature	T _{STG}	-55 to +150	°C

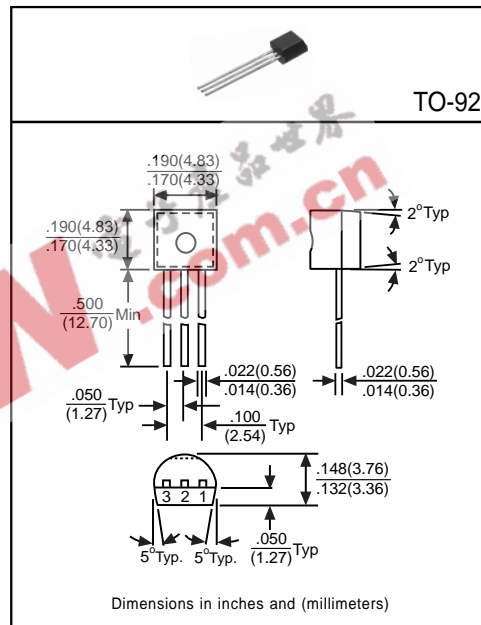

Electrical Characteristics

(Ratings at 25°C ambient temperature unless otherwise specified)

Characteristic	Symbol	Min	Typ	Max	Unit	Test Conditions
Collector-Base Breakdown Voltage	BV _{CB0}	25	-	-	V	I _C =10μA
Collector-Emitter Breakdown Voltage	BV _{CEO}	20	-	-	V	I _C =1mA
Emitter-Base Breakdown Voltage	BV _{EBO}	5	-	-	V	I _E =10μA
Collector Cutoff Current	I _{CBO}	-	-	1	μA	V _{CB} =20V
Emitter Cutoff Current	I _{EBO}	-	-	0.1	μA	V _{EB} =6V
Collector-Emitter Saturation Voltage ⁽¹⁾	V _{CE(sat)}	-	-	0.6	V	I _C =0.5A, I _B =50mA
Base-Emitter On Voltage ⁽¹⁾	V _{BE(on)}	-	-	1	V	I _C =150mA, V _{CE} =1V
DC Current Gain ⁽¹⁾	h _{FE1}	85	-	500	-	I _C =150mA, V _{CE} =1V
	h _{FE2}	-	170	-	-	I _C =500mA, V _{CE} =1V
Transition Frequency	f _T	150	-	-	MHz	I _C =20mA, V _{CE} =10V, f=100MHz
Output Capacitance	C _{ob}	-	-	10	pF	V _{CB} =10V, f=1MHz

(1) Pulse Test: Pulse Width ≤ 380μs, Duty Cycle ≤ 2%

Classification of h_{FE1}

Rank	B	C	D	E
Range	85~160	100~200	150~300	250~500

RATING AND CHARACTERISTIC CURVES OF DC8050S

FIG.1 - Current Gain & Collector Current

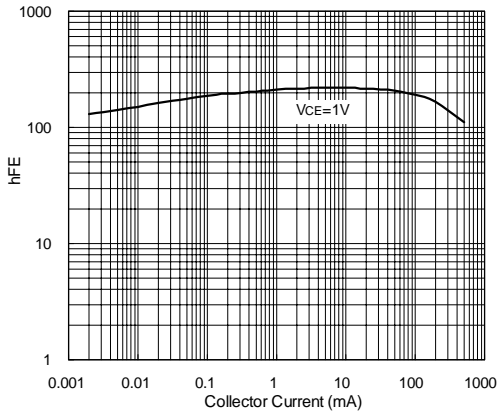

FIG.2 - Saturation Voltage & Collector Current

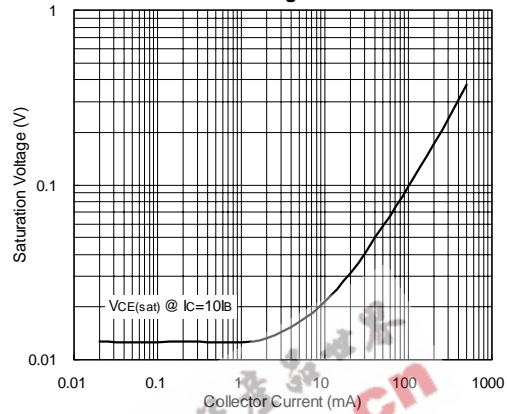

FIG.3 - On Voltage & Collector Current

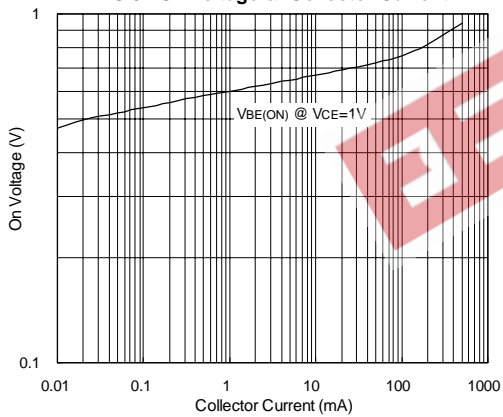

FIG.4 - Cutoff Frequency & Collector Current

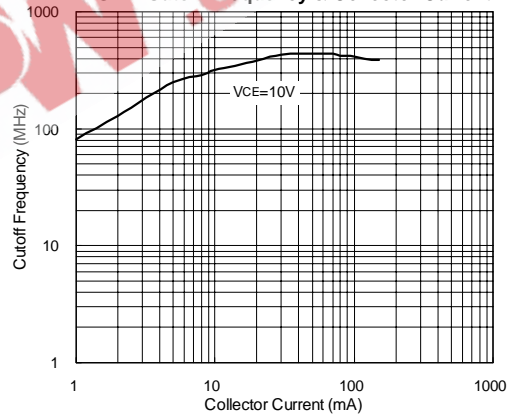

FIG.5 - Capacitance & Reverse-Biased Voltage

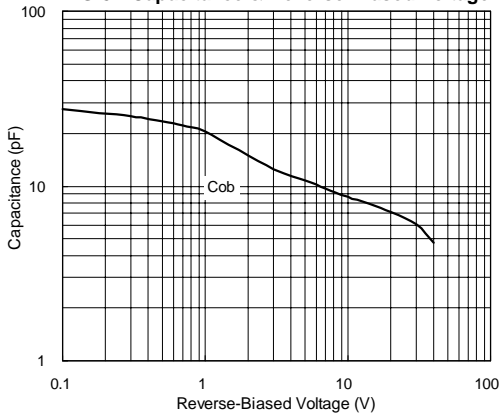

FIG.6 - PD-Ta

