

Features

- Epitaxial Planar Die Construction
- Complementary NPN Types Available (DDTD)
- Built-In Biasing Resistors
- **Lead Free/RoHS Compliant (Note 1)**

Mechanical Data

- Case: SOT-23
- Case Material: Molded Plastic. UL Flammability Classification Rating 94V-0
- Moisture Sensitivity: Level 1 per J-STD-020C
- Terminal Connections: See Diagram
- Terminals: Solderable per MIL-STD-202, Method 208
- Lead Free Plating (Matte Tin Finish annealed over Alloy 42 leadframe).
- Marking: Date Code and Type Code (See Table Below & Page 2)
- Ordering Information (See Page 2)
- Weight: 0.008 grams (approximate)

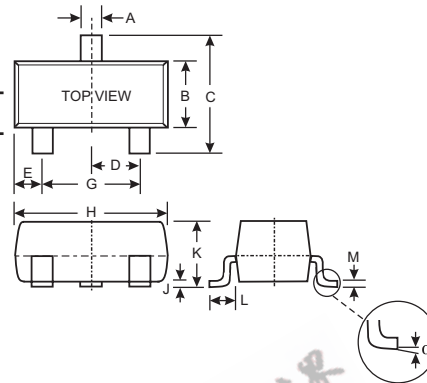

SOT-23		
Dim	Min	Max
A	0.37	0.51
B	1.20	1.40
C	2.30	2.50
D	0.89	1.03
E	0.45	0.60
G	1.78	2.05
H	2.80	3.00
J	0.013	0.10
K	0.903	1.10
L	0.45	0.61
M	0.085	0.180
α	0°	8°

All Dimensions in mm

P/N	R1 (NOM)	R2 (NOM)	Type Code
DDTB122LC	0.22K Ω	10K Ω	P75
DDTB142JC	0.47K Ω	10K Ω	P76
DDTB122TC	0.22K Ω	OPEN	P77
DDTB142TC	0.47K Ω	OPEN	P78

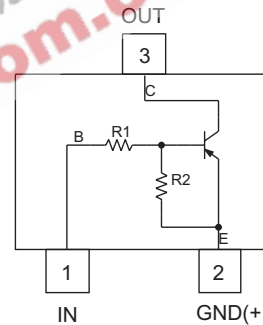

Schematic and Pin Configuration

Maximum Ratings @ T_A = 25°C unless otherwise specified

Characteristic	Symbol	Value	Unit
Supply Voltage, (3) to (2)	V _{CC}	-50	V
Input Voltage, (1) to (2)	V _{IN}	+5 to -6 +5 to -6	V
Input Voltage, (2) to (1)	V _{EBO (MAX)}	-5	V
Output Current	I _C	-500	mA
Power Dissipation (Note 2)	P _d	200	mW
Thermal Resistance, Junction to Ambient Air (Note 2)	R _{θJA}	625	°C/W
Operating and Storage and Temperature Range	T _J , T _{STG}	-55 to +150	°C

- Note: 1. No purposefully added lead.
2. Mounted on FR4 PC Board with recommended pad layout at <http://www.diodes.com/datasheets/ap02001.pdf>.

Electrical Characteristics @ T_A = 25°C unless otherwise specified

R1, R2 Types

Characteristic	Symbol	Min	Typ	Max	Unit	Test Condition	
Input Voltage	DDTB122LC DDTB142JC	V _{I(off)}	-0.3 -0.3	—	—	V	V _{CC} = -5V, I _O = -100μA
	DDTB122LC DDTB142JC	V _{I(on)}	—	—	-2.0 -2.0	V	V _O = -0.3V, I _O = -20mA V _O = -0.3V, I _O = -20mA
Output Voltage		V _{O(on)}	—	—	-0.3V	V	I _O /I _I = -50mA/-2.5mA
Input Current	DDTB122LC DDTB142JC	I _I	—	—	-28 -13	mA	V _I = -5V
Output Current		I _{O(off)}	—	—	-0.5	μA	V _{CC} = -50V, V _I = 0V
DC Current Gain	DDTB122LC DDTB142JC	G _I	56 56	—	—	—	V _O = -5V, I _O = -50mA
Gain-Bandwidth Product*		f _T	—	200	—	MHz	V _{CE} = -10V, I _E = -5mA, f = 100MHz

* Transistor - For Reference Only

Electrical Characteristics @ T_A = 25°C unless otherwise specified

R1-Only Types

Characteristic	Symbol	Min	Typ	Max	Unit	Test Condition	
Collector-Base Breakdown Voltage	BV _{CBO}	-50	—	—	V	I _C = -50μA	
Collector-Emitter Breakdown Voltage	BV _{CEO}	-40	—	—	V	I _C = -1mA	
Emitter-Base Breakdown Voltage	DDTB122TC DDTB142TC	BV _{EBO}	-5	—	V	I _E = -50μA I _E = -50μA	
Collector Cutoff Current		I _{CBO}	—	—	μA	V _{CB} = -50V	
Emitter Cutoff Current	DDTB122TC DDTB142TC	I _{EBO}	—	—	μA	V _{EB} = -4V	
Collector-Emitter Saturation Voltage		V _{CE(sat)}	—	-0.3	V	I _C = -50mA, I _B = -2.5mA	
DC Current Transfer Ratio	DDTB122TC DDTB142TC	h _{FE}	100 100	250 250	600 600	I _C = -5mA, V _{CE} = -5V	
Gain-Bandwidth Product*		f _T	—	200	—	MHz	V _{CE} = -10V, I _E = 5mA, f = 100MHz

* Transistor - For Reference Only

Ordering Information (Note 3)

Device	Packaging	Shipping
DDTB122LC-7-F	SOT-23	3000/Tape & Reel
DDTB142JC-7-F	SOT-23	3000/Tape & Reel
DDTB122TC-7-F	SOT-23	3000/Tape & Reel
DDTB142TC-7-F	SOT-23	3000/Tape & Reel

Notes: 3. For Packaging Details, go to our website at <http://www.diodes.com/datasheets/ap02007.pdf>.

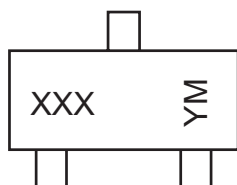
Marking Information

XXX = Product Type Marking Code, See Table on Page 1
 YM = Date Code Marking
 Y = Year ex: T = 2006
 M = Month ex: 9 = September

Date Code Key

Year	2006	2007	2008	2009	2010	2011	2012
Code	T	U	V	W	X	Y	Z

Month	Jan	Feb	Mar	Apr	May	Jun	Jul	Aug	Sep	Oct	Nov	Dec
Code	1	2	3	4	5	6	7	8	9	O	N	D

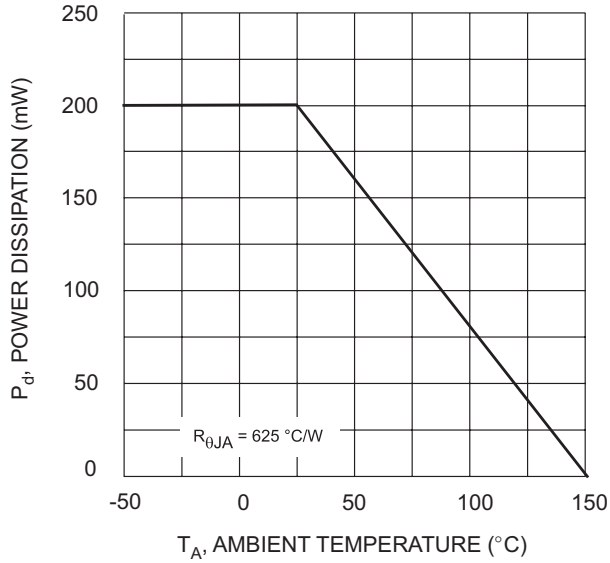

Fig. 1 Power Derating Curve

IMPORTANT NOTICE

Diodes Incorporated and its subsidiaries reserve the right to make modifications, enhancements, improvements, corrections or other changes without further notice to any product herein. Diodes Incorporated does not assume any liability arising out of the application or use of any product described herein; neither does it convey any license under its patent rights, nor the rights of others. The user of products in such applications shall assume all risks of such use and will agree to hold Diodes Incorporated and all the companies whose products are represented on our website, harmless against all damages.

LIFE SUPPORT

Diodes Incorporated products are not authorized for use as critical components in life support devices or systems without the expressed written approval of the President of Diodes Incorporated.