

Tous droits réservés. Reproduction ou communication de ces tiers interdite sans autorisation écrite de la FCI. Toute réimpression sans la permission écrite de la FCI est formellement interdite.

**A**  
FCI

All rights reserved. Reproduction or communication of these parts in any form without the written permission of FCI is strictly prohibited. Any reprinting without the written permission of FCI is strictly prohibited.

U

**A**  
FCI

C

D

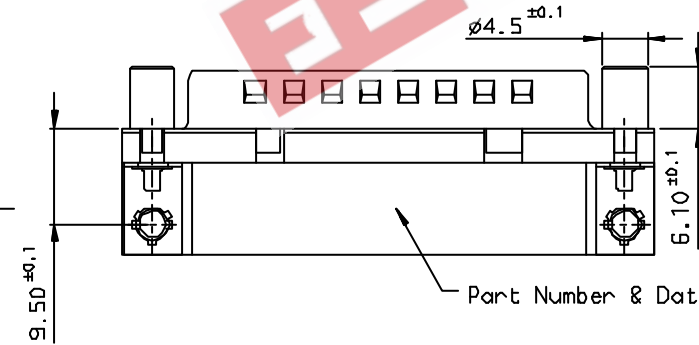
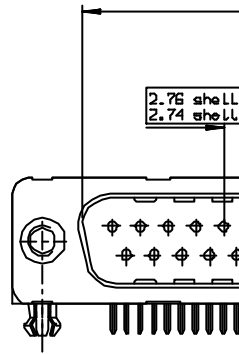
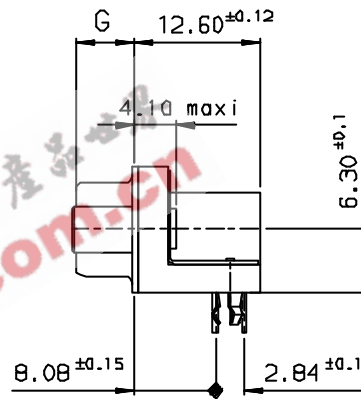
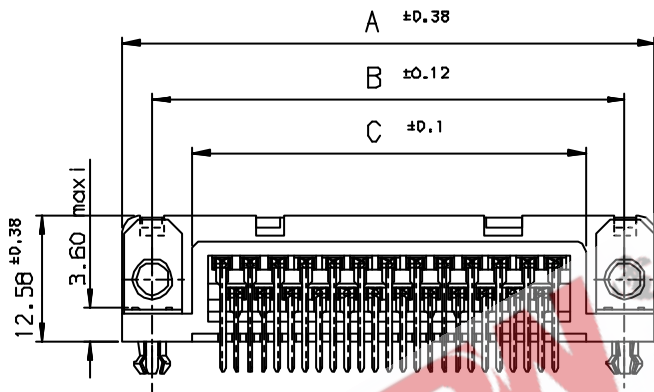

PC card drilling dimensions (after plating)  
(thickness 1.50 ± 0.20mm)

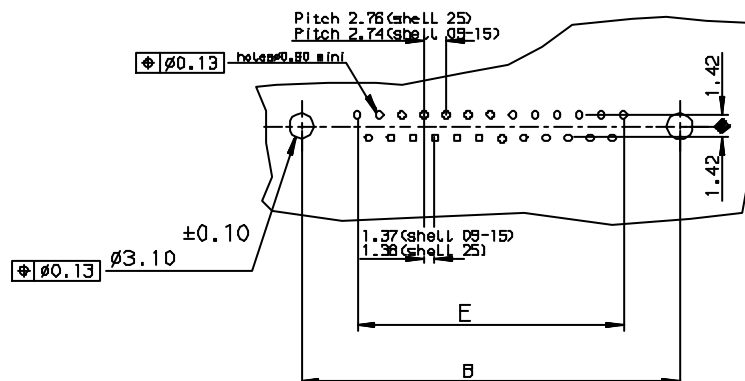

| PuLL Parts |         |         |        |
|------------|---------|---------|--------|
| SHELL      | A ±0.38 | B ±0.12 | C ±0.1 |
| 09         | 30.81   | 24.99   | 16.96  |
| 15         | 39.14   | 33.32   | 25.18  |
| 25         | 53.03   | 47.04   | 39.12  |

GENERAL CHARACTERISTICS - SEE DRAWING

| Dr          | Eng       | Chr       | Appr           |
|-------------|-----------|-----------|----------------|
| JOHN SLEEBA | GEORGE VJ | GEORGE VJ | K Somasundaram |
| 7/4/03      | 7/4/03    | 27/7/05   | 27/7/05        |
|             |           |           |                |
|             |           |           |                |
|             |           |           |                |
|             |           |           |                |
|             |           |           |                |
|             |           |           |                |
|             |           |           |                |
|             |           |           |                |

|      |                |         |       |
|------|----------------|---------|-------|
| Dr   | JOHN SLEEBA    | 7/4/03  | Produ |
| Eng  | GEORGE VJ      | 7/4/03  | Spec  |
| Chr  | GEORGE VJ      | 27/7/05 | Mat   |
| Appr | K Somasundaram | 27/7/05 |       |

| d     | 27/7/05 | LEAD FREE DETAILS ADDED |
|-------|---------|-------------------------|
| INDEX | DATE    | REVISION DESCRIPTION    |
| 1     |         |                         |
| 2     |         |                         |

|                 |            |  |
|-----------------|------------|--|
| <b>A</b><br>FCI | Title      | MALE CONNECT. DELTA screwlock, harpoon & |
|                 | Catalog no | DEL                                      |