

10-TAP, TTL-INTERFACED FIXED DELAY LINE (SERIES DDU7F)



FEATURES

- Ten equally spaced outputs
- Fits standard 14-pin DIP socket
- Low profile
- Auto-insertable
- Input & outputs fully TTL interfaced & buffered
- 10 T²L fan-out capability

PACKAGES

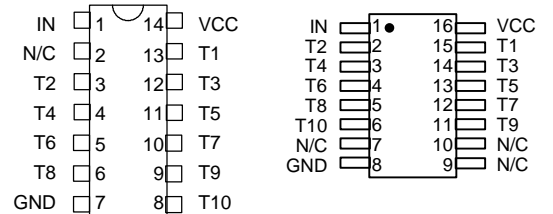

DDU7F-xx	DIP	Military SMD
DDU7F-xxA2	Gull-Wing	DDU7F-xxMC3
DDU7F-xxB2	J-Lead	
DDU7F-xxM	Military DIP	

FUNCTIONAL DESCRIPTION

The DDU7F-series device is a 10-tap digitally buffered delay line. The signal input (IN) is reproduced at the outputs (T1-T10), shifted in time by an amount determined by the device dash number. The nominal tap-to-tap delay increment is given by 1/10 of the dash number. For dash numbers less than 50, the total delay of the line is measured from T1 to T10, with the nominal value given by 9 times the increment. The inherent delay from IN to T1 is nominally 3.5ns. For dash numbers greater than or equal to 50, the total delay of the line is measured from IN to T10, with the nominal value given by the dash number.

PIN DESCRIPTIONS

IN	Signal Input
T1-T10	Tap Outputs
VCC	+5 Volts
GND	Ground

SERIES SPECIFICATIONS

- **Minimum input pulse width:** 20% of total delay
- **Output rise time:** 2ns typical
- **Supply voltage:** 5VDC ± 5%
- **Supply current:** I_{CC}L = 50ma typical
I_{CC}H = 15ma typical
- **Operating temperature:** 0° to 70° C
- **Temp. coefficient of total delay:** 100 PPM/°C

DASH NUMBER SPEC.'S

Part Number	Total Delay (ns)	Delay Per Tap (ns)
DDU7F-10	9 ± 2.0 *	1.0 ± 0.5
DDU7F-20	18 ± 2.0 *	2.0 ± 1.0
DDU7F-25	22.5 ± 2.0 *	2.5 ± 1.0
DDU7F-50	50 ± 2.5	5.0 ± 2.0
DDU7F-100	100 ± 5.0	10.0 ± 3.0
DDU7F-150	150 ± 7.5	15.0 ± 3.0
DDU7F-200	200 ± 10.0	20.0 ± 3.0
DDU7F-250	250 ± 12.5	25.0 ± 3.0
DDU7F-300	300 ± 15.0	30.0 ± 3.0
DDU7F-400	400 ± 20.0	40.0 ± 4.0
DDU7F-500	500 ± 25.0	50.0 ± 5.0

* Total delay is referenced to first tap
Input to first tap = 3.5ns ± 1ns

NOTE: Any dash number between 10 and 500 not shown is also available.

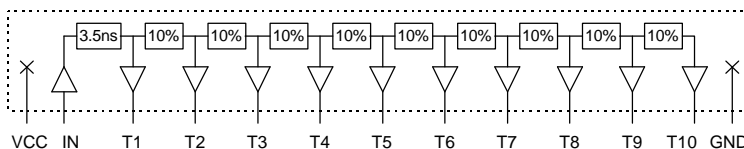

Functional diagram for dash numbers < 50

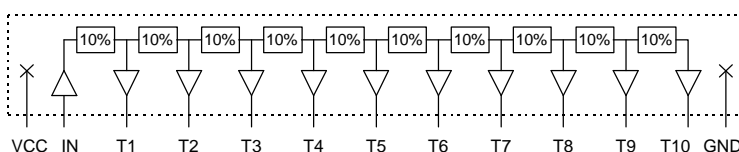

Functional diagram for dash numbers >= 50

APPLICATION NOTES

HIGH FREQUENCY RESPONSE

The DDU7F tolerances are guaranteed for input pulse widths and periods greater than those specified in the test conditions. Although the device will function properly for pulse widths as small as 20% of the total delay and periods as small as 40% of the total delay (for a symmetric input), the delays may deviate from their values at low frequency. However, for a given input condition, the deviation will be repeatable from pulse to pulse. Contact technical support at Data

Delay Devices if your application requires device testing at a specific input condition.

POWER SUPPLY BYPASSING

The DDU7F relies on a stable power supply to produce repeatable delays within the stated tolerances. A 0.1uf capacitor from VCC to GND, located as close as possible to the VCC pin, is recommended. A wide VCC trace and a clean ground plane should be used.

DEVICE SPECIFICATIONS

TABLE 1: ABSOLUTE MAXIMUM RATINGS

PARAMETER	SYMBOL	MIN	MAX	UNITS	NOTES
DC Supply Voltage	V _{CC}	-0.3	7.0	V	
Input Pin Voltage	V _{IN}	-0.3	V _{CC} +0.3	V	
Storage Temperature	T _{STRG}	-55	150	C	
Lead Temperature	T _{LEAD}		300	C	10 sec

TABLE 2: DC ELECTRICAL CHARACTERISTICS

(0C to 70C, 4.75V to 5.25V)

PARAMETER	SYMBOL	MIN	TYP	MAX	UNITS	NOTES
High Level Output Voltage	V _{OH}	2.5	3.4		V	V _{CC} = MIN, I _{OH} = MAX V _{IH} = MIN, V _{IL} = MAX
Low Level Output Voltage	V _{OL}		0.35	0.5	V	V _{CC} = MIN, I _{OL} = MAX V _{IH} = MIN, V _{IL} = MAX
High Level Output Current	I _{OH}			-1.0	mA	
Low Level Output Current	I _{OL}			20.0	mA	
High Level Input Voltage	V _{IH}	2.0			V	
Low Level Input Voltage	V _{IL}			0.8	V	
Input Clamp Voltage	V _{IK}			-1.2	V	V _{CC} = MIN, I _I = I _{IK}
Input Current at Maximum Input Voltage	I _{IHH}			0.1	mA	V _{CC} = MAX, V _I = 7.0V
High Level Input Current	I _{IH}			20	μA	V _{CC} = MAX, V _I = 2.7V
Low Level Input Current	I _{IL}			-0.6	mA	V _{CC} = MAX, V _I = 0.5V
Short-circuit Output Current	I _{OS}	-60		-150	mA	V _{CC} = MAX
Output High Fan-out				25	Unit	
Output Low Fan-out				12.5	Load	

PACKAGE DIMENSIONS

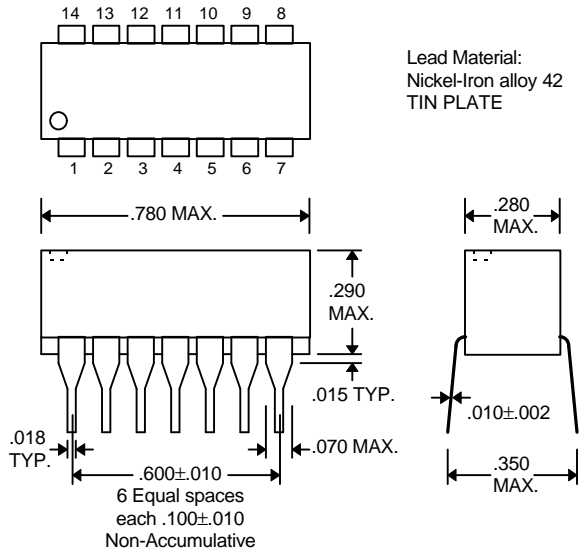

DDU7F-xx (Commercial DIP)

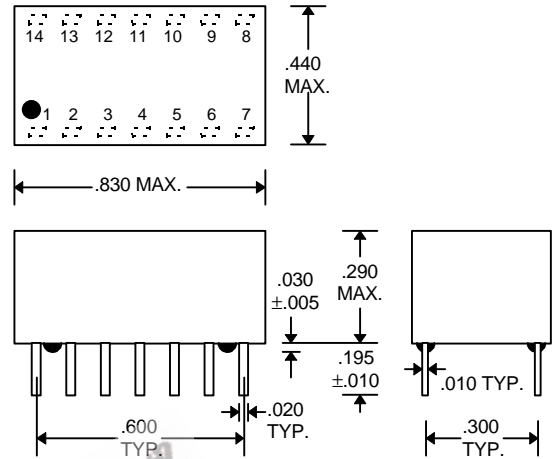

DDU7F-xxM (Military DIP)

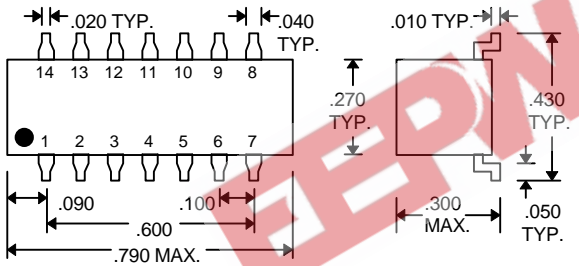

DDU7F-xxA2 (Commercial Gull-Wing)

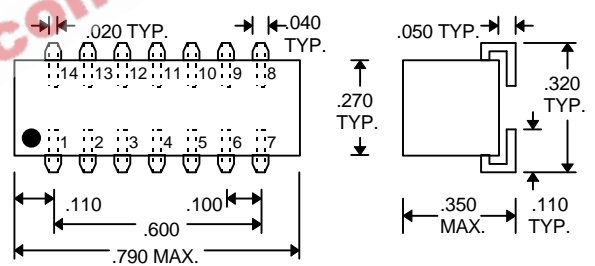

DDU7F-xxB2 (Commercial J-Lead)

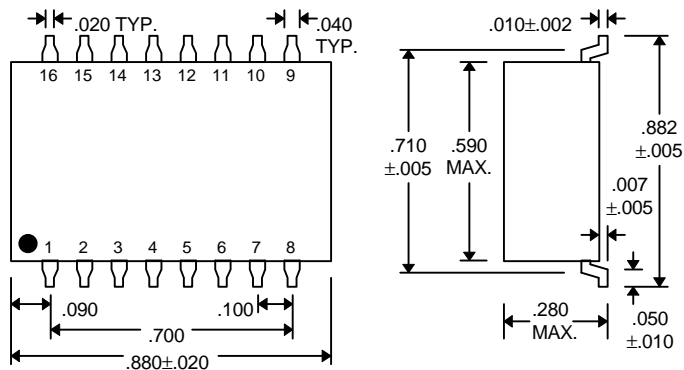

DDU7F-xxMC3 (Military Gull-Wing)

DELAY LINE AUTOMATED TESTING

TEST CONDITIONS

INPUT:

Ambient Temperature: $25^{\circ}\text{C} \pm 3^{\circ}\text{C}$
Supply Voltage (Vcc): $5.0\text{V} \pm 0.1\text{V}$
Input Pulse: High = $3.0\text{V} \pm 0.1\text{V}$
 Low = $0.0\text{V} \pm 0.1\text{V}$

Source Impedance: 50Ω Max.

Rise/Fall Time: 3.0 ns Max. (measured between 0.6V and 2.4V)

Pulse Width: $PW_{IN} = 1.5 \times \text{Total Delay}$

Period: $PER_{IN} = 10 \times \text{Total Delay}$

OUTPUT:

Load: 1 FAST-TTL Gate

C_{load}: $5\text{pf} \pm 10\%$

Threshold: 1.5V (Rising & Falling)

NOTE: The above conditions are for test only and do not in any way restrict the operation of the device.

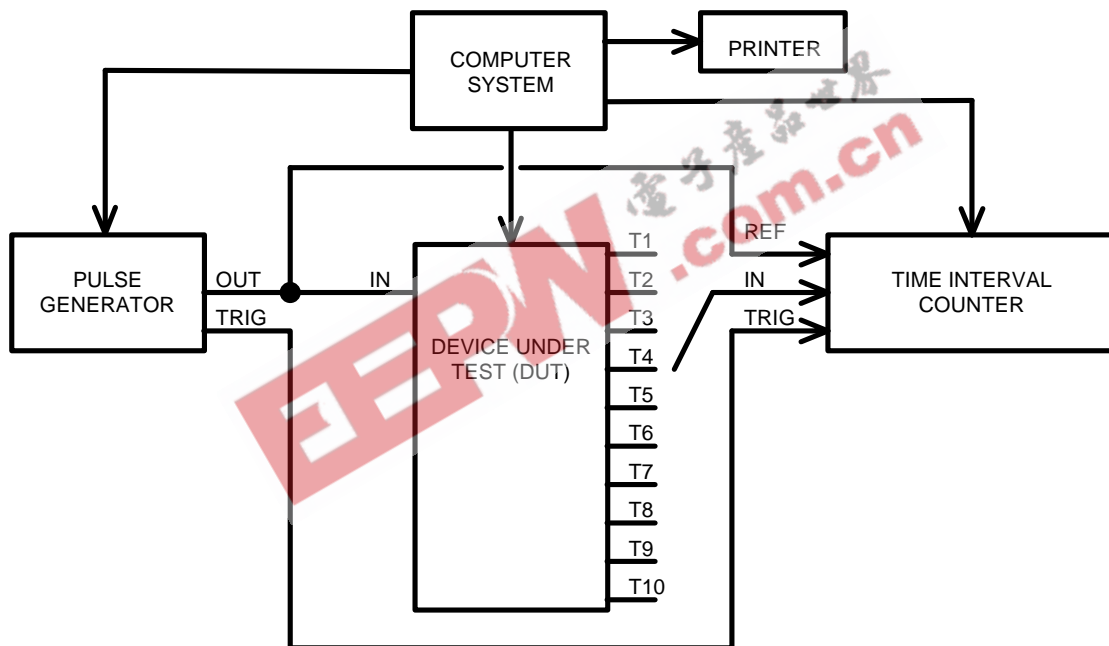

Test Setup

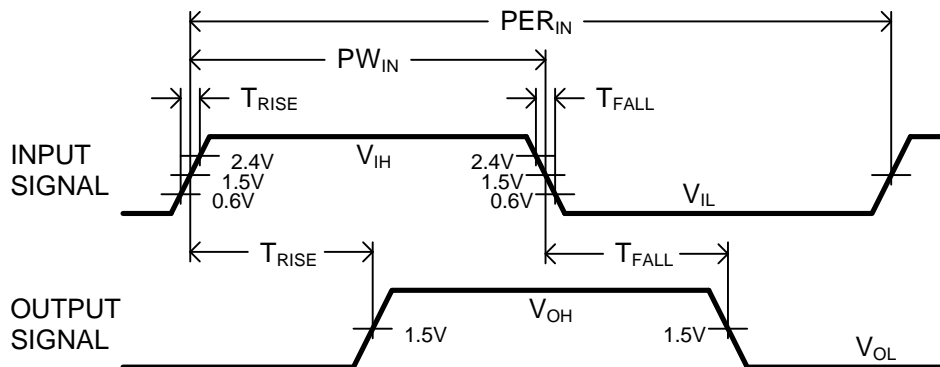

Timing Diagram For Testing