

## Features

- Epitaxial Planar Die Construction
- Complementary PNP Types Available (DDTB)
- Built-In Biasing Resistors
- Lead Free Product

## Mechanical Data

- Case: SOT-23, Molded Plastic
- Case material - UL Flammability Rating 94V-0
- Moisture sensitivity: Level 1 per J-STD-020A
- Terminals: Finish - Matte Tin (Note 1)  
Solderable per MIL-STD-202, Method 208
- Terminal Connections: See Diagram
- Marking: Date Code and Marking Code (See Diagrams & Page 2)
- Weight: 0.008 grams (approx.)
- Ordering Information (See Page 2)

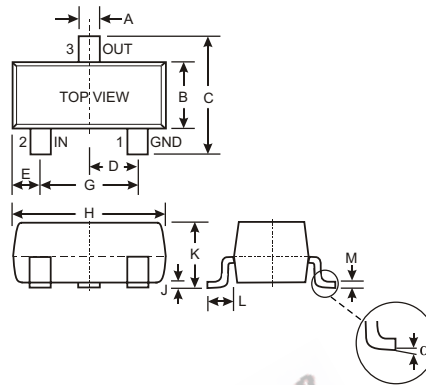

SOT-23		
Dim	Min	Max
A	0.37	0.51
B	1.20	1.40
C	2.30	2.50
D	0.89	1.03
E	0.45	0.60
G	1.78	2.05
H	2.80	3.00
J	0.013	0.10
K	0.903	1.10
L	0.45	0.61
M	0.085	0.180
$\alpha$	0°	8°
All Dimensions in mm		

P/N	R1 (NOM)	R2 (NOM)	MARKING
DDTD122LC	0.22K $\Omega$	10K $\Omega$	N75
DDTD142JC	0.47K $\Omega$	10K $\Omega$	N76
DDTD122TC	0.22K $\Omega$	OPEN	N77
DDTD142TC	0.47K $\Omega$	OPEN	N78

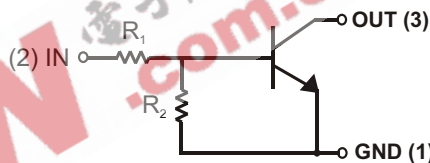

## Maximum Ratings @ T<sub>A</sub> = 25°C unless otherwise specified

Characteristic	Symbol	Value	Unit
Supply Voltage, (3) to (1)	V <sub>CC</sub>	50	V
Input Voltage, (2) to (1)	V <sub>IN</sub>	-5 to +6	V
Input Voltage, (1) to (2)	V <sub>EBO (MAX)</sub>	5	V
Output Current	I <sub>C</sub>	500	mA
Power Dissipation (Note 2)	P <sub>d</sub>	200	mW
Thermal Resistance, Junction to Ambient Air (Note 2)	R <sub>θJA</sub>	625	°C/W
Operating and Storage and Temperature Range	T <sub>j</sub> , T <sub>STG</sub>	-55 to +150	°C

- Note: 1. If lead-bearing terminal plating is required, please contact your Diodes Inc. sales representative for availability and minimum order details.  
2. Mounted on FR4 PC Board with recommended pad layout at <http://www.diodes.com/datasheets/ap02001.pdf>.

**Electrical Characteristics** @ T<sub>A</sub> = 25°C unless otherwise specified

**R1, R2 Types**

Characteristic		Symbol	Min	Typ	Max	Unit	Test Condition
Input Voltage	DDTD122LC DDTD142JC	V <sub>I(off)</sub>	0.3 0.3	—	—	V	V <sub>CC</sub> = 5V, I <sub>O</sub> = 100μA
	DDTD122LC DDTD142JC	V <sub>I(on)</sub>	—	—	2.0 2.0	V	V <sub>O</sub> = 0.3V, I <sub>O</sub> = 20mA V <sub>O</sub> = 0.3V, I <sub>O</sub> = 20mA
Output Voltage		V <sub>O(on)</sub>	—	—	0.3V	V	I <sub>O</sub> /I <sub>I</sub> = 50mA/2.5mA
Input Current	DDTD122LC DDTD142JC	I <sub>I</sub>	—	—	28 13	mA	V <sub>I</sub> = 5V
Output Current		I <sub>O(off)</sub>	—	—	0.5	μA	V <sub>CC</sub> = 50V, V <sub>I</sub> = 0V
DC Current Gain	DDTD122LC DDTD142JC	G <sub>I</sub>	56 56	—	—	—	V <sub>O</sub> = 5V, I <sub>O</sub> = 50mA
Gain-Bandwidth Product*		f <sub>T</sub>	—	200	—	MHz	V <sub>CE</sub> = 10V, I <sub>E</sub> = 5mA, f = 100MHz

\* Transistor - For Reference Only

**Electrical Characteristics** @ T<sub>A</sub> = 25°C unless otherwise specified

**R1-Only, R2-Only Types**

Characteristic		Symbol	Min	Typ	Max	Unit	Test Condition
Collector-Base Breakdown Voltage		BV <sub>CBO</sub>	50	—	—	V	I <sub>C</sub> = 50μA
Collector-Emitter Breakdown Voltage		BV <sub>CEO</sub>	40	—	—	V	I <sub>C</sub> = 1mA
Emitter-Base Breakdown Voltage	DDTD122TC DDTD142TC	BV <sub>EBO</sub>	5	—	—	V	I <sub>E</sub> = 50μA I <sub>E</sub> = 50μA
Collector Cutoff Current		I <sub>CBO</sub>	—	—	0.5	μA	V <sub>CB</sub> = 50V
Emitter Cutoff Current	DDTD122TC DDTD142TC	I <sub>EBO</sub>	—	—	0.5 0.5	μA	V <sub>EB</sub> = 4V
Collector-Emitter Saturation Voltage		V <sub>CE(sat)</sub>	—	—	0.3	V	I <sub>C</sub> = 50mA, I <sub>B</sub> = 2.5mA
DC Current Transfer Ratio	DDTD122TC DDTD142TC	h <sub>FE</sub>	100 100	250 250	600 600	—	I <sub>C</sub> = 5mA, V <sub>CE</sub> = 5V
Gain-Bandwidth Product*		f <sub>T</sub>	—	200	—	MHz	V <sub>CE</sub> = 10V, I <sub>E</sub> = -5mA, f = 100MHz

\* Transistor - For Reference Only

**Ordering Information** (Note 3)

Device	Packaging	Shipping
DDTD122LC-7	SOT-23	3000/Tape & Reel
DDTD142JC-7	SOT-23	3000/Tape & Reel
DDTD122TC-7	SOT-23	3000/Tape & Reel
DDTD142TC-7	SOT-23	3000/Tape & Reel

- Notes: 1. If lead-bearing terminal plating is required, please contact your Diodes Inc. sales representative for availability and minimum order details.  
3. For Packaging Details, go to our website at <http://www.diodes.com/datasheets/ap02007.pdf>.

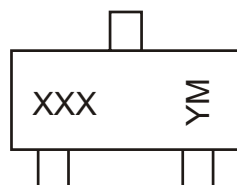
**Marking Information**

XXX = Product Type Marking Code  
See Sheet 1 Diagrams  
YM = Date Code Marking  
Y = Year ex: P = 2003  
M = Month ex: 9 = September

Date Code Key

Year	2002	2003	2004	2005	2006	2007	2008	2009
Code	N	P	R	S	T	U	V	W

Month	Jan	Feb	March	Apr	May	Jun	Jul	Aug	Sep	Oct	Nov	Dec
Code	1	2	3	4	5	6	7	8	9	O	N	D

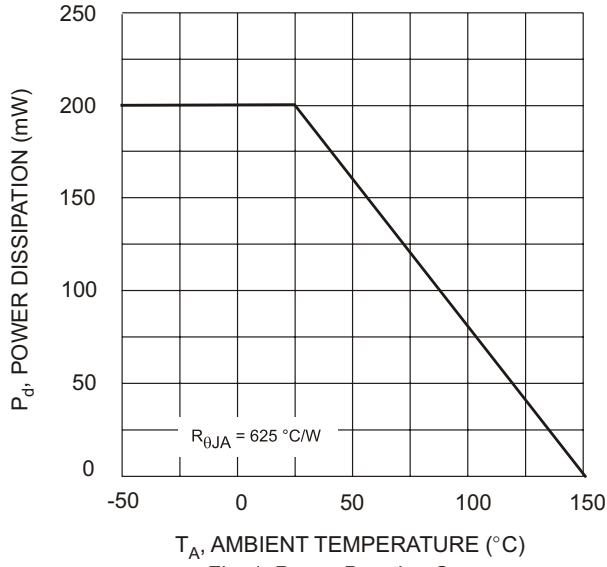

Fig. 1 Power Derating Curve

EEPW 电子产品世界 .com.cn