

**D1FK70****700V 0.8A****特長**

- 小型SMD
- 高耐圧
- 低ノイズ
- $V_{RM} = 700V$

**Feature**

- Small SMD
- High Voltage
- Low Noise
- $V_{RM} = 700V$

**用途**

- スイッチング電源
- DC/DC コンバータ
- フライホイール
- 家電、OA、照明
- 通信、FA

**Main Use**

- Switching Regulator
- DC/DC Converter
- Fly Wheel
- Home Appliance, Office Automation, Lighting
- Communication, Factory Automation

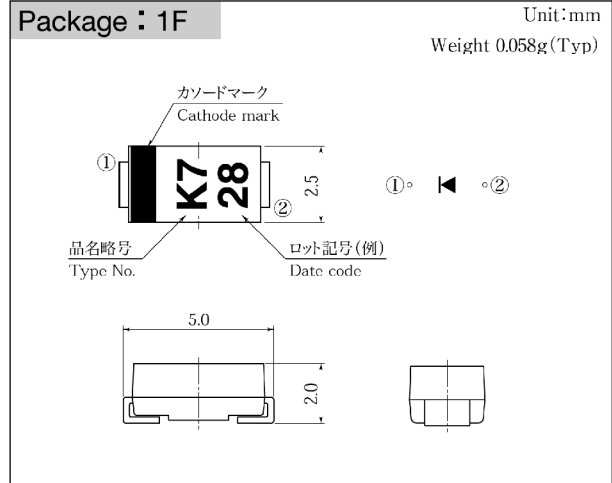
**■外観図 OUTLINE**

外形図については新電元Webサイト又は〈ダイオードカタログ・技術資料編〉を参照下さい。捺印表示については捺印仕様をご確認下さい。

For details of the outline dimensions, refer to our web site or the diode technical data book. As for the marking, refer to the specification "Marking, Terminal Connection".

**■定格表 RATINGS****●絶対最大定格 Absolute Maximum Ratings (指定のない場合  $T_l = 25^\circ C$ )**

項目 Item	記号 Symbol	条件 Conditions	品名 Type No.	D1FK70	単位 Unit
保存温度 Storage Temperature	$T_{stg}$			-55~150	$^\circ C$
接合部温度 Operation Junction Temperature	$T_j$			150	$^\circ C$
せん頭逆電圧 Maximum Reverse Voltage	$V_{RM}$			700	V
出力電流 Average Rectified Forward Current	$I_o$	50Hz 正弦波, 抵抗負荷 50Hz sine wave, Resistance load	$T_a = 32^\circ C$ アルミナ基板実装 On alumina substrate	0.8	A
			$T_a = 33^\circ C$ プリント基板実装 On glass-epoxy substrate	0.6	
せん頭サージ順電流 Peak Surge Forward Current	$I_{FSM}$	50Hz 正弦波, 非繰り返し1サイクルせん頭値, $T_j = 25^\circ C$ 50Hz sine wave, Non-repetitive 1 cycle peak value, $T_j = 25^\circ C$		25	A

**●電氣的・熱的特性 Electrical Characteristics (指定のない場合  $T_l = 25^\circ C$ )**

順電圧 Forward Voltage	$V_F$	$I_F = 0.8A$ , パルス測定 Pulse measurement		MAX 1.3	V
逆電流 Reverse Current	$I_R$	$V_R = V_{RM}$ , パルス測定 Pulse measurement		MAX 10	$\mu A$
逆回復時間 Reverse Recovery Time	$t_{rr}$	$I_F = 0.5A, I_R = 1A$		MAX 400	ns
接合容量 Junction Capacitance	$C_j$	$f = 1MHz, V_R = 10V$		TYP 7	pF
熱抵抗 Thermal Resistance	$\theta_{jl}$	接合部・リード間 Junction to lead		MAX 23	$^\circ C/W$
	$\theta_{ja}$	接合部・周囲間 Junction to ambient	アルミナ基板実装 On alumina substrate プリント基板実装 On glass-epoxy substrate	MAX 108 MAX 157	

★記載内容は製品改良のためにお断りなしに変更することがあります。

★All specifications are subject to change without notice.

■特性図 CHARACTERISTIC DIAGRAMS

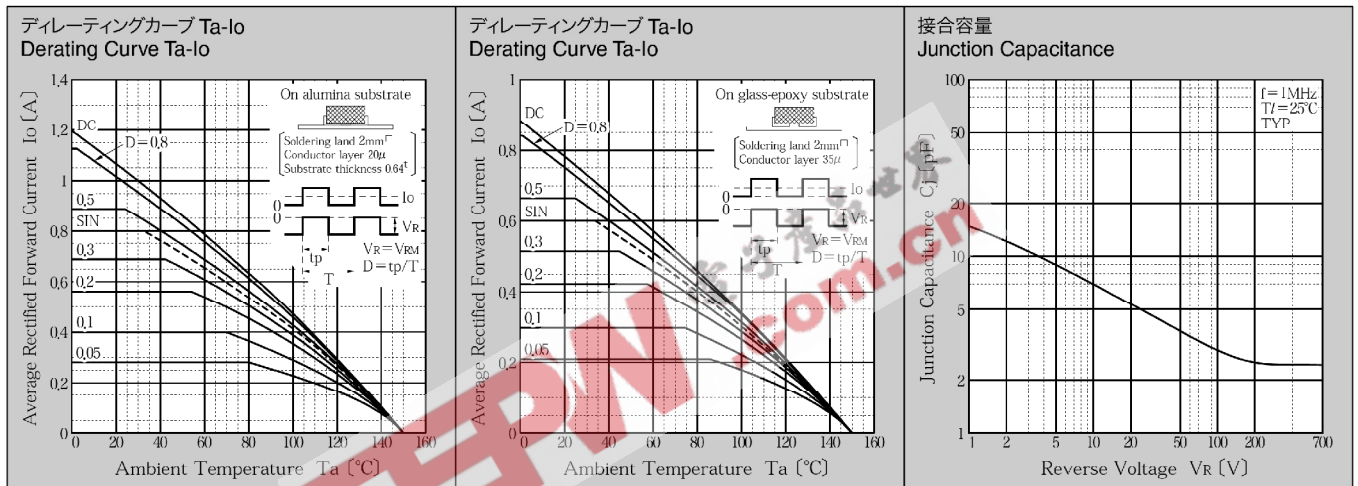
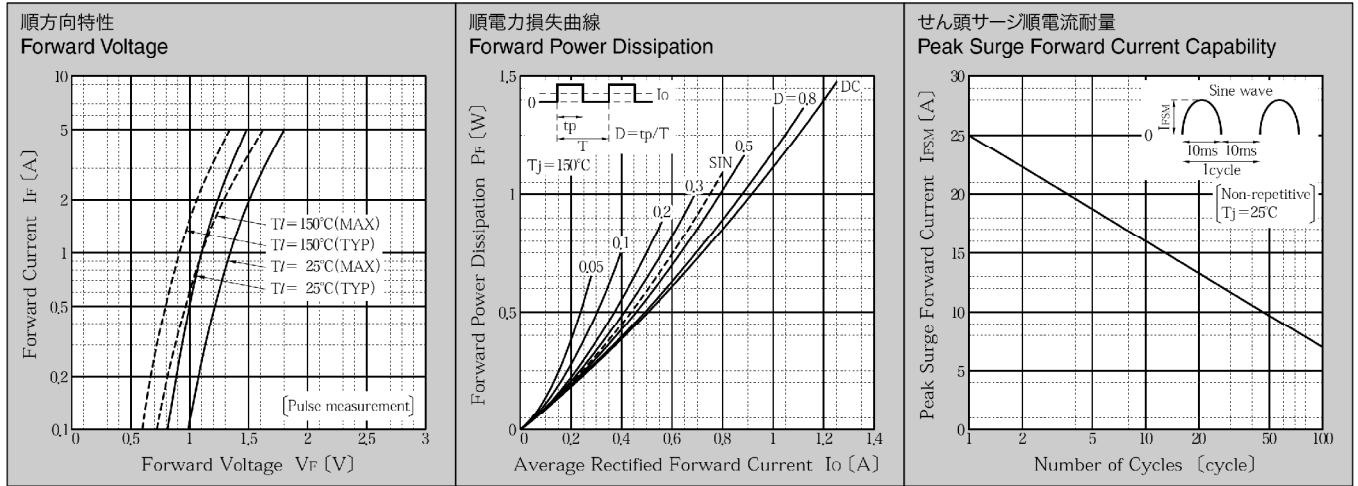

\* Sine wave は 50Hz で測定しています。  
 \* 50Hz sine wave is used for measurements.  
 \* 半導体製品の特性は一般的にバラツキを持っています。  
 Typical is statistical average of the device's ability.  
 \* Semiconductor products generally have characteristic variation.  
 Typical is a statistical average of the device's ability.