

DIODE MODULE

DD(KD)100GB40/80



UL;E76102 (M)

Power Diode Module **DD100GB** series are designed for various rectifier circuits. **DD100GB** has two diode chips connected in series and the mounting base is electrically isolated from elements for simple heatsink construction. Wide voltage rating up to, 800V is available for various input voltage.

- Isolated mounting base
- Two elements in a package for simple (single and three phase) bridge connections
- Highly reliable glass passivated chips
- High surge current capability

(Applications)

Various rectifiers, Battery chargers, DC motor drives

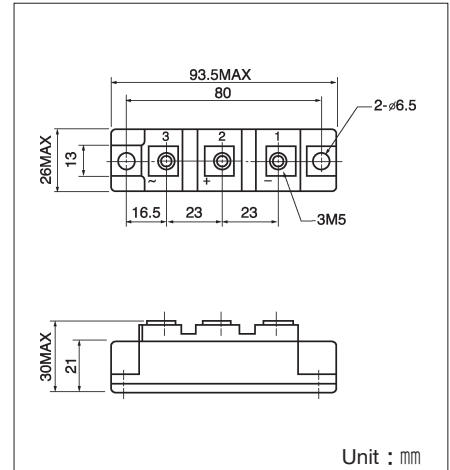
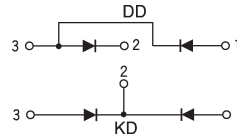

Maximum Ratings

(T_j=25°C)

Symbol	Item	Ratings		Unit
		DD100GB40	DD100GB80	
V _{RRM}	Repetitive Peak Reverse Voltage	400	800	V
V _{RSM}	Non-Repetitive Peak Reverse Voltage	480	960	V

Symbol	Item	Conditions	Ratings	Unit	
I _{F(AV)}	Average Forward Current	Single phase, half wave, 180° conduction, T _c : 115°C	100	A	
I _{F(RMS)}	R.M.S. Forward Current	Single phase, half wave, 180° conduction, T _c : 115°C	155	A	
I _{FSM}	Surge Forward Current	1/2 cycle, 50/60Hz, peak value, non-repetitive	1800/2000	A	
I ² t	I ² t	Value for one cycle of surge current	16500	A ² S	
T _j	Junction Temperature		-40~+150	°C	
T _{stg}	Storage Temperature		-40~+125	°C	
V _{ISO}	Isolation Breakdown Voltage (R.M.S.)	A.C.1minute	2500	V	
	Mounting Torque	Mounting (M6)	Recommended Value 2.5~3.9 (25~40)	4.7 (48)	N·m (kgf·cm)
		Terminal (M5)	Recommended Value 1.5~2.5 (15~25)	2.7 (28)	
	Mass		170	g	

Electrical Characteristics

Symbol	Item	Conditions	Ratings	Unit
I _{RRM}	Repetitive Peak Reverse Current, max.	at V _{DRM} , single phase, half wave. T _j =150°C	30	mA
V _{FM}	Forward Voltage Drop, max.	Foward current 320A, T _j =25°C, Inst. measurement	1.25	V
R _{th(j-c)}	Thermal Impedance, max.	Junction to case	0.30	°C/W

