

SHINDENGEN

Super Fast Recovery Rectifiers

Modules

D200LC40B

400V 200A

FEATURES

High current capacity
trr150ns
Insulated Package

APPLICATION

Semiconductor Production Equipment
Big Power Supply
Factory Automation, Robot

OUTLINE DIMENSIONS

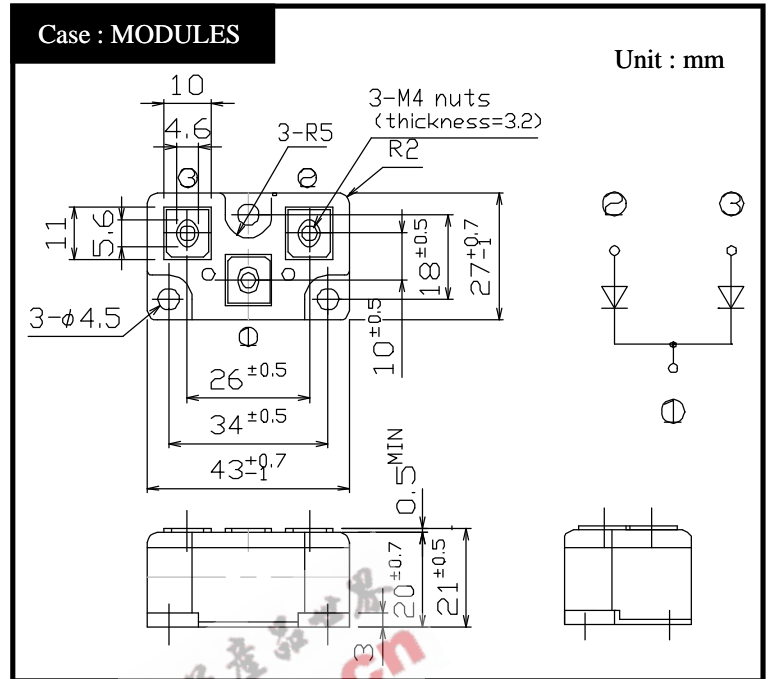

RATINGS

Absolute Maximum Ratings (If not specified Tc=25)

Item	Symbol	Conditions	Ratings	Unit
Storage Temperature	Tstg		-40 ~ 150	
Operating Junction Temperature	Tj		150	
Maximum Reverse Voltage	V _{RM}		400	V
Average Rectified Forward Current	I _O	50Hz sine wave, R-load, Rating for each arm I _o /2, Tc=52	200	A
Peak Surge Forward Current	I _{FSM}	50Hz sine wave, Non-repetitive 1 cycle peak value, Rating of per arm Tj=25	1400	A
Dielectric Strength	V _{dis}	Terminals to case, AC 1 minute	1.5	kV
Mounting Torque	TOR		1.7	N·m

Electrical Characteristics (If not specified Tc=25)

Item	Symbol	Conditions	Ratings	Unit
Forward Voltage	V _F	I _F =100A, Pulse measurement, Rating of per arm	Max.1.3	V
Reverse Current	I _R	V _R =V _{RM} , Pulse measurement, Rating of per arm	Max.50	μ A
Reverse Recovery Time	trr	I _F =0.5A, I _R =1A, Rating of per arm	Max.150	ns
Thermal Resistance	jc	junction to case	Max.0.35	/W

D200LC40B Forward Voltage

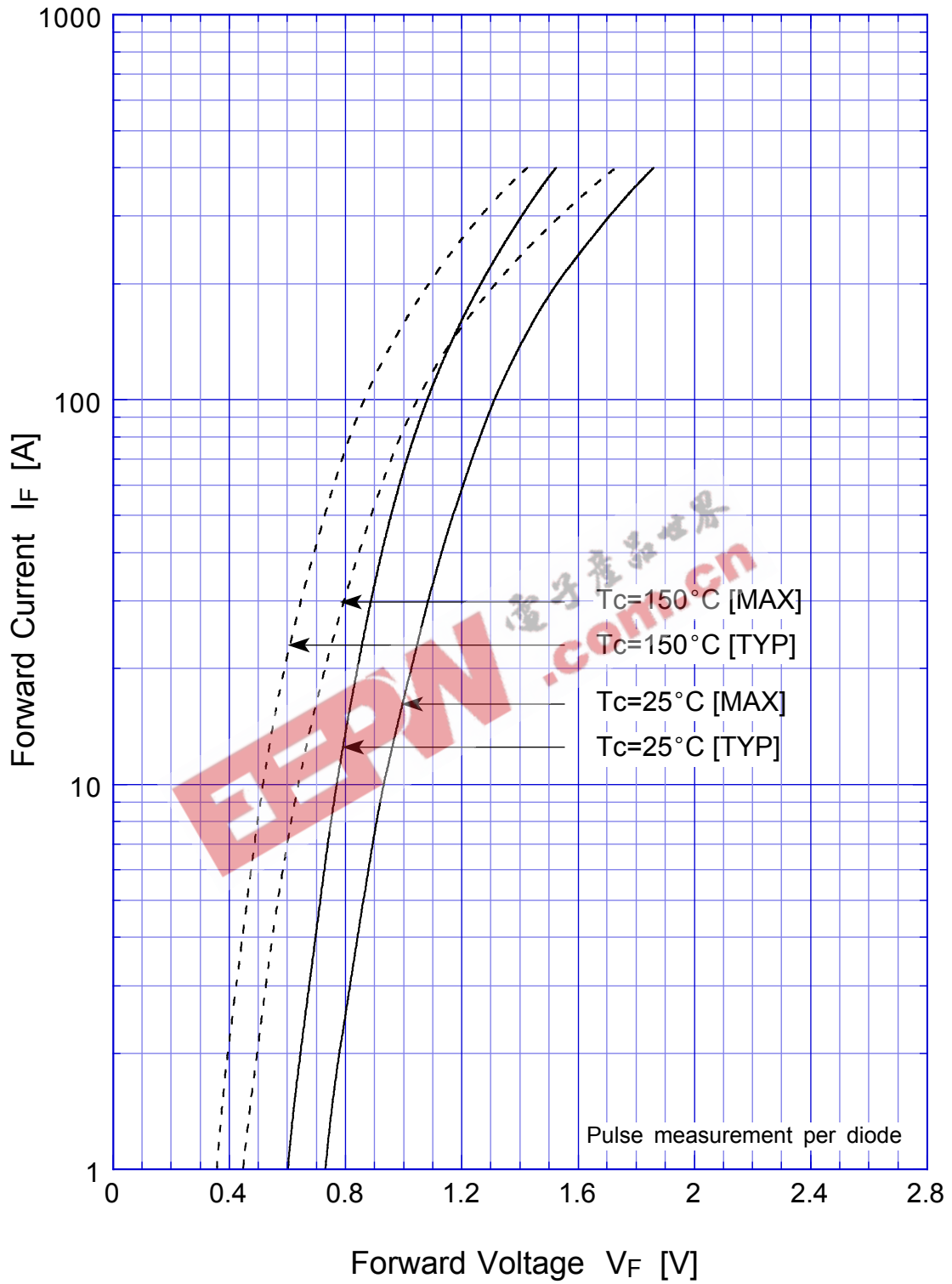

D200LC40B Forward Power Dissipation

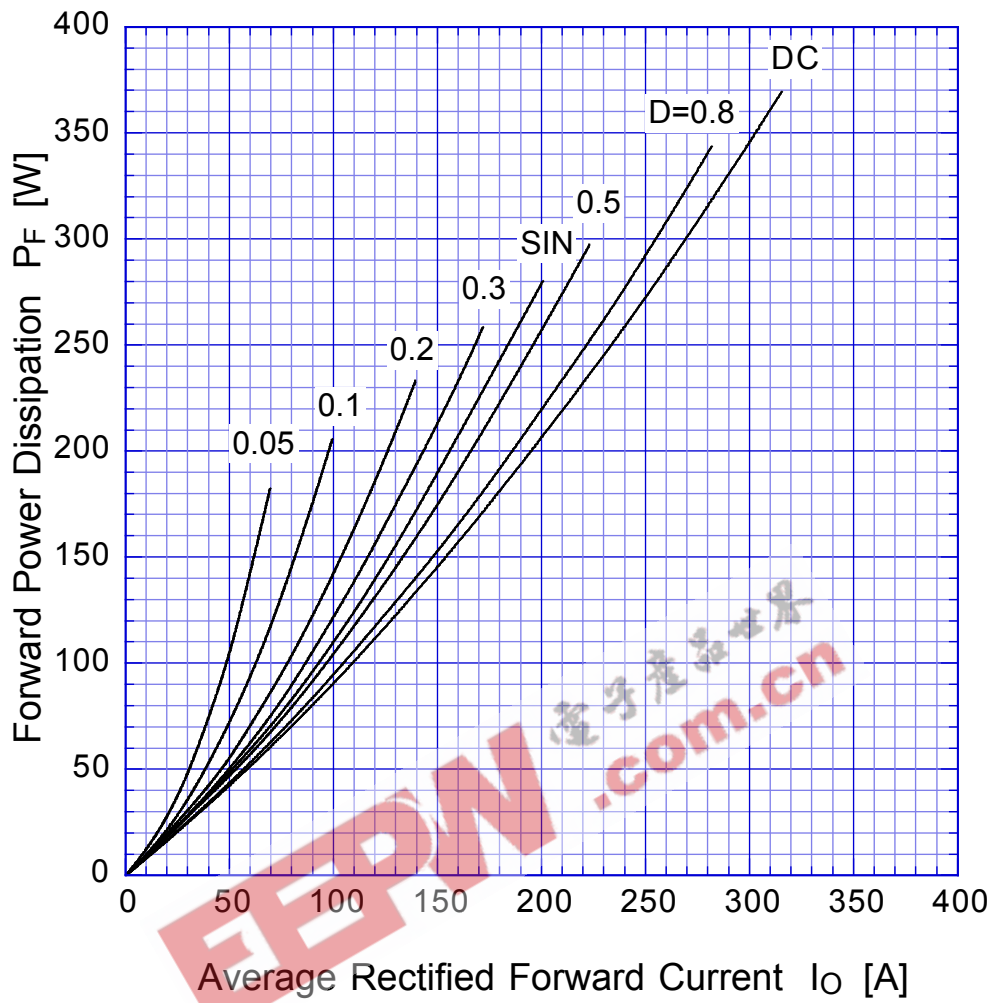

$T_j = T_{jmax}$



D200LC40B

Derating Curve

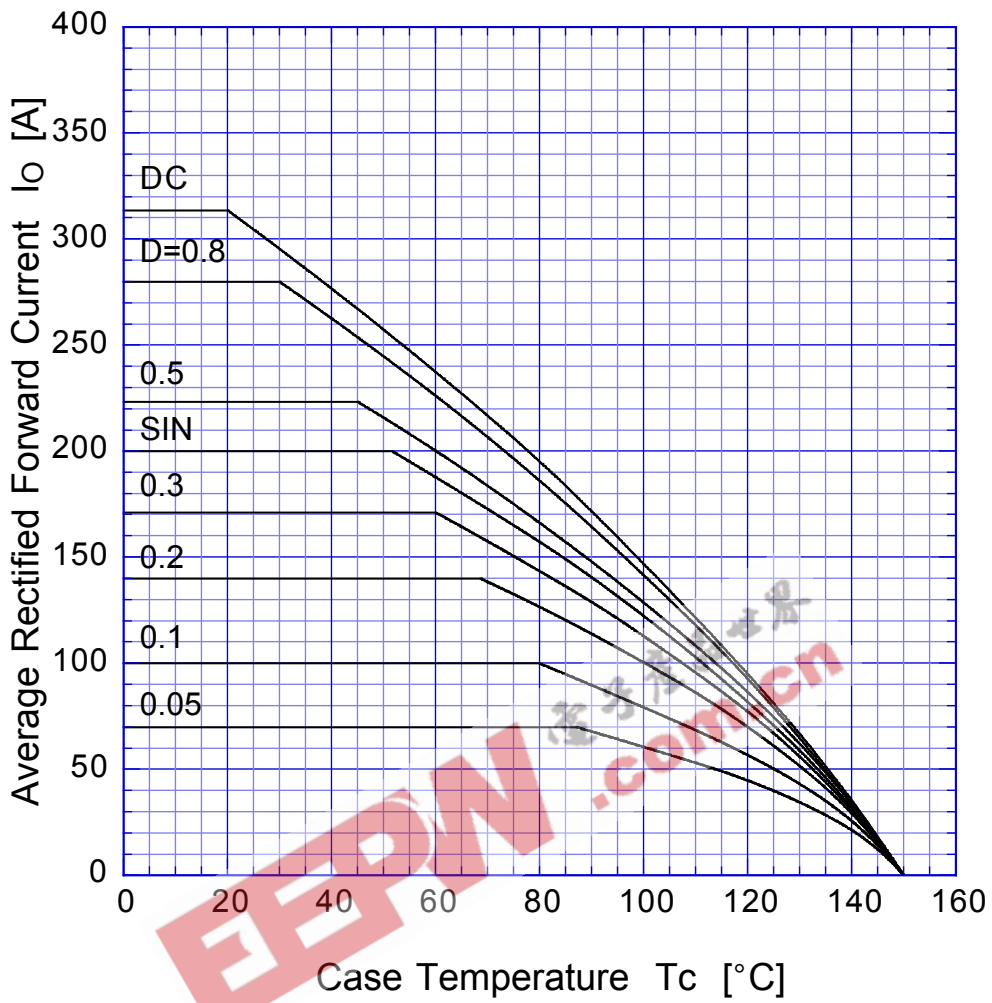

$$V_R = V_{RM}$$



D200LC40B Peak Surge Forward Capability

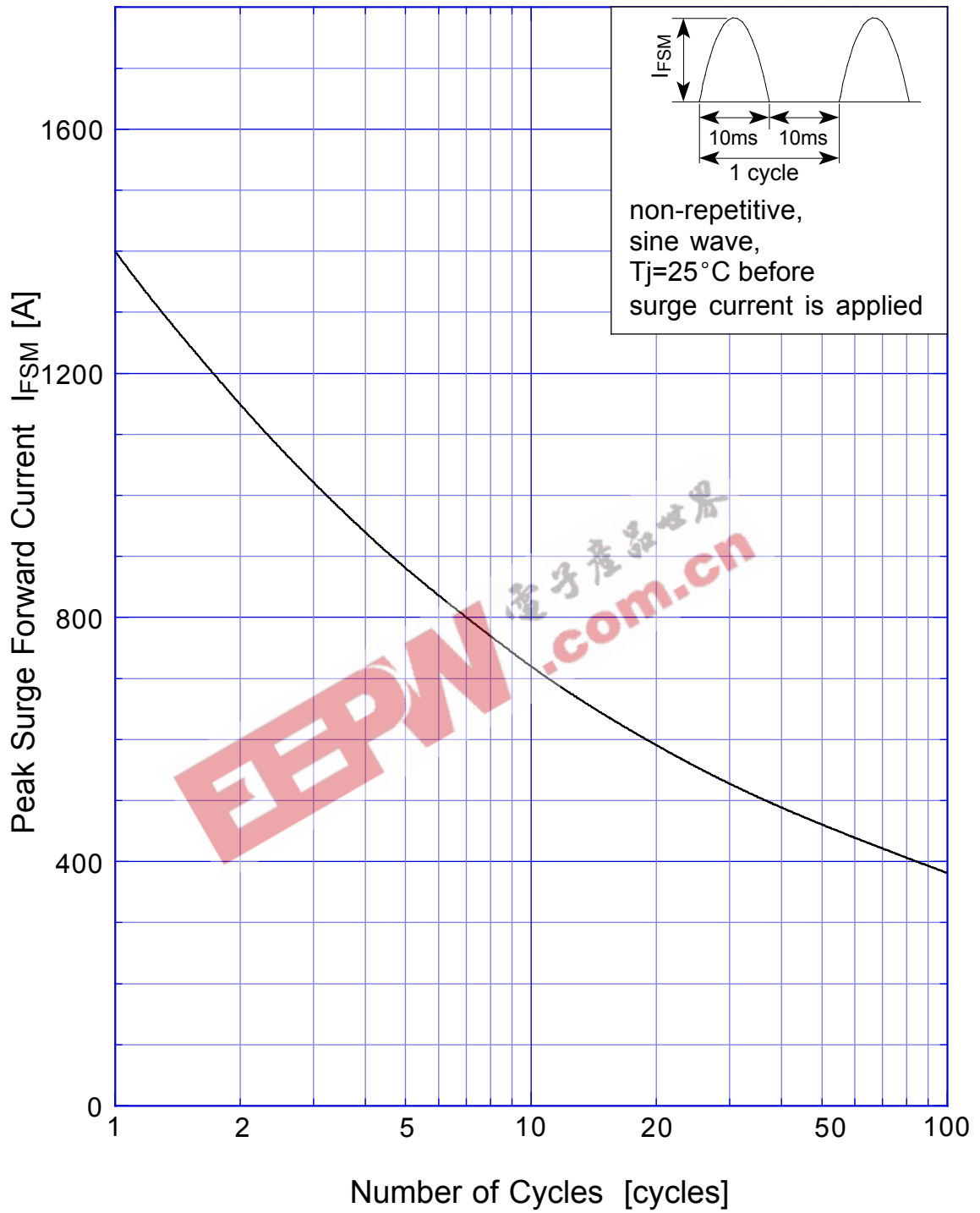

D200LC40B Junction Capacitance

