



DAC904

For most current data sheet and other product information, visit [www.burr-brown.com](http://www.burr-brown.com)

## SpeedPlus™ 14-Bit, 165MSPS DIGITAL-TO-ANALOG CONVERTER

### FEATURES

- SINGLE +5V OR +3V OPERATION
- HIGH SFDR: 20MHz Output at 100MSPS: 64dBc
- LOW GLITCH: 3pV-s
- LOW POWER: 170mW at +5V
- INTERNAL REFERENCE:
  - Optional Ext. Reference
  - Adjustable Full-Scale Range
  - Multiplying Option

### DESCRIPTION

The DAC904 is a high-speed, digital-to-analog converter (DAC) offering a 14-bit resolution option within the SpeedPlus family of high-performance converters. Featuring pin compatibility among family members, the DAC908, DAC900, and DAC902 provide a component selection option to an 8-, 10-, and 12-bit resolution, respectively. All models within this family of D/A converters support update rates in excess of 165MSPS with excellent dynamic performance, and are especially suited to fulfill the demands of a variety of applications.

The advanced segmentation architecture of the DAC904 is optimized to provide a high Spurious-Free Dynamic Range (SFDR) for single-tone, as well as for multi-tone signals—essential when used for the transmit signal path of communication systems.

The DAC904 has a high impedance (200kΩ) current output with a nominal range of 20mA and an output compliance of up to 1.25V. The differential outputs allow for both a differential, or single-ended analog signal interface. The close matching of the current outputs ensures superior dynamic performance in the differential configuration, which can be implemented with a transformer.

Utilizing a small geometry CMOS process, the monolithic DAC904 can be operated on a wide, single-supply range of +2.7V to +5.5V. Its low power consumption allows for use in portable and battery operated systems. Further optimization can be realized by lowering the output current with the adjustable full-scale option.

### APPLICATIONS

- COMMUNICATION TRANSMIT CHANNELS
  - WLL, Cellular Base Station
  - Digital Microwave Links
  - Cable Modems
- WAVEFORM GENERATION
  - Direct Digital Synthesis (DDS)
  - Arbitrary Waveform Generation (ARB)
- MEDICAL/ULTRASOUND
- HIGH-SPEED INSTRUMENTATION AND CONTROL
- VIDEO, DIGITAL TV

For noncontinuous operation of the DAC904, a power-down mode results in only 45mW of standby power.

The DAC904 comes with an integrated 1.24V bandgap reference and edge-triggered input latches, offering a complete converter solution. Both +3V and +5V CMOS logic families can be interfaced to the DAC904.

The reference structure of the DAC904 allows for additional flexibility by utilizing the on-chip reference, or applying an external reference. The full-scale output current can be adjusted over a span of 2mA to 20mA, with one external resistor, while maintaining the specified dynamic performance.

The DAC904 is available in SO-28 and TSSOP-28 packages.

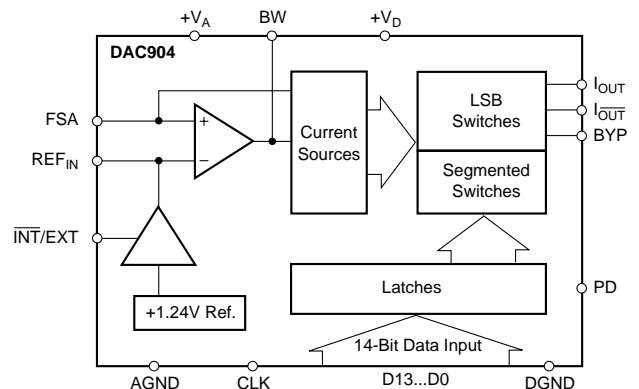

# SPECIFICATIONS

At  $T_A$  = full specified temperature range,  $+V_A = +5V$ ,  $+V_D = +5V$ , differential transformer coupled output, 50Ω doubly terminated, unless otherwise specified.

PARAMETER	CONDITIONS	DAC904U/E			UNITS
		MIN	TYP	MAX	
Resolution			14		Bits
Output Update Rate ( $f_{CLOCK}$ )	4.5V to 5.5V	165	200		MSPS
Output Update Rate	2.7V to 3.3V	125	165		MSPS
Full Specified Temperature Range, Operating	Ambient, $T_A$	-40		+85	°C
<b>STATIC ACCURACY<sup>(1)</sup></b>	$T_A = +25^\circ C$				
Differential Nonlinearity (DNL)	$f_{CLOCK} = 25\text{MSPS}$ , $f_{OUT} = 1.0\text{MHz}$		±2.5		LSB
Integral Nonlinearity (INL)			±3.0		LSB
<b>DYNAMIC PERFORMANCE</b>	$T_A = +25^\circ C$				
Spurious Free Dynamic Range (SFDR)	To Nyquist				
$f_{OUT} = 1.0\text{MHz}$ , $f_{CLOCK} = 25\text{MSPS}$		72	79		dBc
$f_{OUT} = 2.1\text{MHz}$ , $f_{CLOCK} = 50\text{MSPS}$			76		dBc
$f_{OUT} = 5.04\text{MHz}$ , $f_{CLOCK} = 50\text{MSPS}$			68		dBc
$f_{OUT} = 5.04\text{MHz}$ , $f_{CLOCK} = 100\text{MSPS}$			68		dBc
$f_{OUT} = 20.2\text{MHz}$ , $f_{CLOCK} = 100\text{MSPS}$			64		dBc
$f_{OUT} = 25.3\text{MHz}$ , $f_{CLOCK} = 125\text{MSPS}$			60		dBc
$f_{OUT} = 41.5\text{MHz}$ , $f_{CLOCK} = 125\text{MSPS}$			55		dBc
$f_{OUT} = 27.4\text{MHz}$ , $f_{CLOCK} = 165\text{MSPS}$			60		dBc
$f_{OUT} = 54.8\text{MHz}$ , $f_{CLOCK} = 165\text{MSPS}$			55		dBc
Spurious Free Dynamic Range within a Window					
$f_{OUT} = 5.04\text{MHz}$ , $f_{CLOCK} = 50\text{MSPS}$	2MHz Span		82		dBc
$f_{OUT} = 5.04\text{MHz}$ , $f_{CLOCK} = 100\text{MSPS}$	4MHz Span		82		dBc
Total Harmonic Distortion (THD)					
$f_{OUT} = 2.1\text{MHz}$ , $f_{CLOCK} = 50\text{MSPS}$			-75		dBc
$f_{OUT} = 2.1\text{MHz}$ , $f_{CLOCK} = 125\text{MSPS}$			-74		dBc
Two Tone					
$f_{OUT1} = 13.5\text{MHz}$ , $f_{OUT2} = 14.5\text{MHz}$ , $f_{CLOCK} = 100\text{MSPS}$			63		dBc
Output Settling Time <sup>(2)</sup>	to 0.1%		30		ns
Output Rise Time <sup>(2)</sup>	10% to 90%		2		ns
Output Fall Time <sup>(2)</sup>	10% to 90%		2		ns
Glitch Impulse			3		pV-s
<b>DC-ACCURACY</b>					
Full-Scale Output Range <sup>(3)</sup> (FSR)	All Bits High, $I_{OUT}$	2.0		20.0	mA
Output Compliance Range		-1.0		+1.25	V
Gain Error	With Internal Reference	-10	±1	+10	%FSR
Gain Error	With External Reference	-10	±2	+10	%FSR
Gain Drift	With Internal Reference		±120		ppmFSR/°C
Offset Error	With Internal Reference	-0.025		+0.025	%FSR
Offset Drift	With Internal Reference		±0.1		ppmFSR/°C
Power Supply Rejection, $+V_A$		-0.2		+0.2	%FSR/V
Power Supply Rejection, $+V_D$		-0.025		+0.025	%FSR/V
Output Noise	$I_{OUT} = 20\text{mA}$ , $R_{LOAD} = 50\Omega$		50		pA/√Hz
Output Resistance			200		kΩ
Output Capacitance	$I_{OUT}$ , $\overline{I_{OUT}}$ to Ground		12		pF
<b>REFERENCE</b>					
Reference Voltage			+1.24		V
Reference Tolerance			±10		%
Reference Voltage Drift			±50		ppmFSR/°C
Reference Output Current			10		μA
Reference Input Resistance			1		MΩ
Reference Input Compliance Range		0.1		1.25	V
Reference Small Signal Bandwidth <sup>(4)</sup>			1.3		MHz
<b>DIGITAL INPUTS</b>					
Logic Coding			Straight Binary		
Latch Command			Rising Edge of Clock		
Logic High Voltage, $V_{IH}$	$+V_D = +5V$	3.5	5		V
Logic Low Voltage, $V_{IL}$	$+V_D = +5V$		0	1.2	V
Logic High Voltage, $V_{IH}$	$+V_D = +3V$	2	3		V
Logic Low Voltage, $V_{IL}$	$+V_D = +3V$		0	0.8	V
Logic High Current, $I_{IH}$ <sup>(5)</sup>	$+V_D = +5V$		±20		μA
Logic Low Current, $I_{IL}$	$+V_D = +5V$		±20		μA
Input Capacitance			5		pF

The information provided herein is believed to be reliable; however, BURR-BROWN assumes no responsibility for inaccuracies or omissions. BURR-BROWN assumes no responsibility for the use of this information, and all use of such information shall be entirely at the user's own risk. Prices and specifications are subject to change without notice. No patent rights or licenses to any of the circuits described herein are implied or granted to any third party. BURR-BROWN does not authorize or warrant any BURR-BROWN product for use in life support devices and/or systems.

## SPECIFICATIONS (Cont.)

At  $T_A = +25^\circ\text{C}$ ,  $+V_A = +5\text{V}$ ,  $+V_D = +5\text{V}$ , differential transformer coupled output,  $50\Omega$  doubly terminated, unless otherwise specified.

PARAMETER	CONDITIONS	DAC904U/E			UNITS
		MIN	TYP	MAX	
<b>POWER SUPPLY</b>					
Supply Voltages					
+V <sub>A</sub>		+2.7	+5	+5.5	V
+V <sub>D</sub>		+2.7	+5	+5.5	V
Supply Current <sup>(6)</sup>					
I <sub>VA</sub>			24	30	mA
I <sub>VA</sub> , Power-Down Mode			1.1	2	mA
I <sub>VD</sub>			8	15	mA
Power Dissipation	+5V, I <sub>OUT</sub> = 20mA		170	230	mW
	+3V, I <sub>OUT</sub> = 2mA		50		mW
Power Dissipation, Power-Down Mode			45		mW
Thermal Resistance, $\theta_{JA}$					
SO-28			75		$^\circ\text{C/W}$
TSSOP-28			50		$^\circ\text{C/W}$

NOTES: (1) At output I<sub>OUT</sub>, while driving a virtual ground. (2) Measured single-ended into  $50\Omega$  Load. (3) Nominal full-scale output current is  $32 \times I_{REF}$ ; see Application Section for details. (4) Reference bandwidth depends on size of external capacitor at the BW pin and signal level. (5) Typically  $45\mu\text{A}$  for the PD pin, which has an internal pull-down resistor. (6) Measured at  $f_{\text{CLOCK}} = 50\text{MSPS}$  and  $f_{\text{OUT}} = 1.0\text{MHz}$ .

### ABSOLUTE MAXIMUM RATINGS

+VA to AGND .....	-0.3V to +6V
+VD to DGND .....	-0.3V to +6V
AGND to DGND .....	-0.3V to +0.3V
+VA to +VD .....	-6V to +6V
CLK, PD to DGND .....	-0.3V to VD + 0.3V
D0-D13 to DGND .....	-0.3V to VD + 0.3V
I <sub>OUT</sub> , I <sub>OUT</sub> to AGND .....	-1V to VA + 0.3V
BW, BYP to AGND .....	-0.3V to VA + 0.3V
REFIN, FSA to AGND .....	-0.3V to VA + 0.3V
INT/EXT to AGND .....	-0.3V to VA + 0.3V
Junction Temperature .....	+150°C
Case Temperature .....	+100°C
Storage Temperature .....	+125°C



### ELECTROSTATIC DISCHARGE SENSITIVITY

This integrated circuit can be damaged by ESD. Burr-Brown recommends that all integrated circuits be handled with appropriate precautions. Failure to observe proper handling and installation procedures can cause damage.

ESD damage can range from subtle performance degradation to complete device failure. Precision integrated circuits may be more susceptible to damage because very small parametric changes could cause the device not to meet its published specifications.

### PACKAGE/ORDERING INFORMATION

PRODUCT	PACKAGE	PACKAGE DRAWING NUMBER	SPECIFIED TEMPERATURE RANGE	PACKAGE MARKING	ORDERING NUMBER <sup>(1)</sup>	TRANSPORT MEDIA
DAC904U	SO-28	217	-40°C to +85°C	DAC904U	DAC904U	Rails
"	"	"	"	"	DAC904U/1K	Tape and Reel
DAC904E	TSSOP-28	360	-40°C to +85°C	DAC904E	DAC904E	Rails
"	"	"	"	"	DAC904E/2K5	Tape and Reel

NOTE: (1) Models with a slash (/) are available only in Tape and Reel in the quantities indicated (e.g., /2K5 indicates 2500 devices per reel). Ordering 2500 pieces of "DAC904E/2K5" will get a single 2500-piece Tape and Reel.

### DEMO BOARD ORDERING INFORMATION

PRODUCT	DEMO BOARD ORDERING NUMBER	COMMENT
DAC904U	DEM-DAC90xU	Populated evaluation board without D/A converter. Order sample of desired DAC90x model separately.
DAC904E	DEM-DAC904E	Populated evaluation board including the DAC904E.

## PIN CONFIGURATION

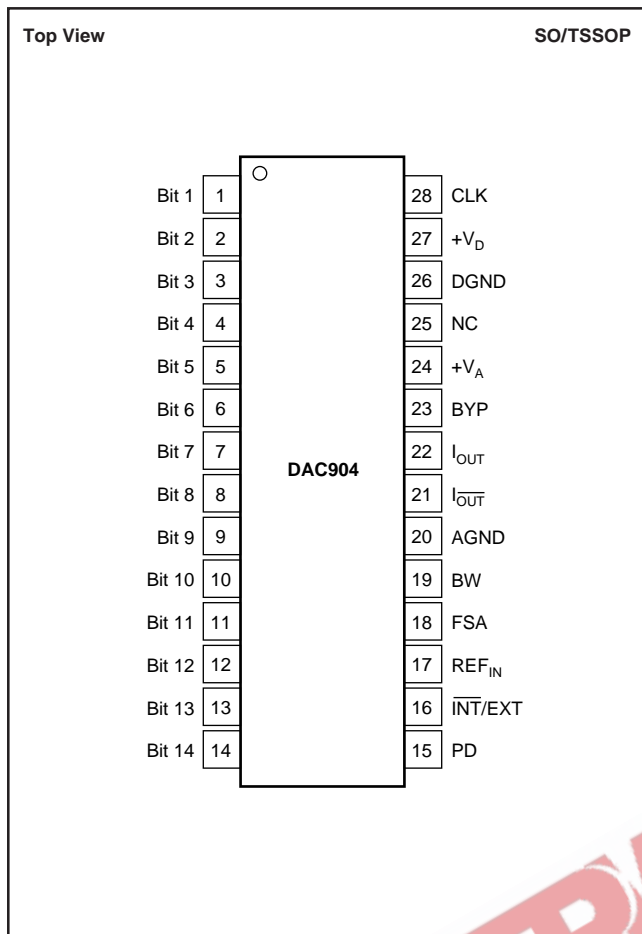

## PIN DESCRIPTIONS

PIN	DESIGNATOR	DESCRIPTION
1	Bit 1	Data Bit 1 (D13), MSB
2	Bit 2	Data Bit 2 (D12)
3	Bit 3	Data Bit 3 (D11)
4	Bit 4	Data Bit 4 (D10)
5	Bit 5	Data Bit 5 (D9)
6	Bit 6	Data Bit 6 (D8)
7	Bit 7	Data Bit 7 (D7)
8	Bit 8	Data Bit 8 (D6)
9	Bit 9	Data Bit 9 (D5)
10	Bit 10	Data Bit 10 (D4)
11	Bit 11	Data Bit 11 (D3)
12	Bit 12	Data Bit 12 (D2)
13	Bit 13	Data Bit 13 (D1)
14	Bit 14	Data Bit 14 (D0), LSB
15	PD	Power Down, Control Input; Active High. Contains internal pull-down circuit; may be left unconnected if not used.
16	INT/EXT	Reference Select Pin; Internal (= 0) or External (= 1) Reference Operation.
17	REF <sub>IN</sub>	Reference Input/Output. See Applications section for further details.
18	FSA	Full-Scale Output Adjust
19	BW	Bandwidth/Noise Reduction Pin: Bypass with 0.1μF to +V <sub>A</sub> for Optimum Performance.
20	AGND	Analog Ground
21	I <sub>OUT</sub>	Complementary DAC Current Output
22	I <sub>OUT</sub>	DAC Current Output
23	BYP	Bypass Node: Use 0.1μF to AGND
24	+V <sub>A</sub>	Analog Supply Voltage, 2.7V to 5.5V
25	NC	No Connection
26	DGND	Digital Ground
27	+V <sub>D</sub>	Digital Supply Voltage, 2.7V to 5.5V
28	CLK	Clock Input

## TYPICAL CONNECTION CIRCUIT

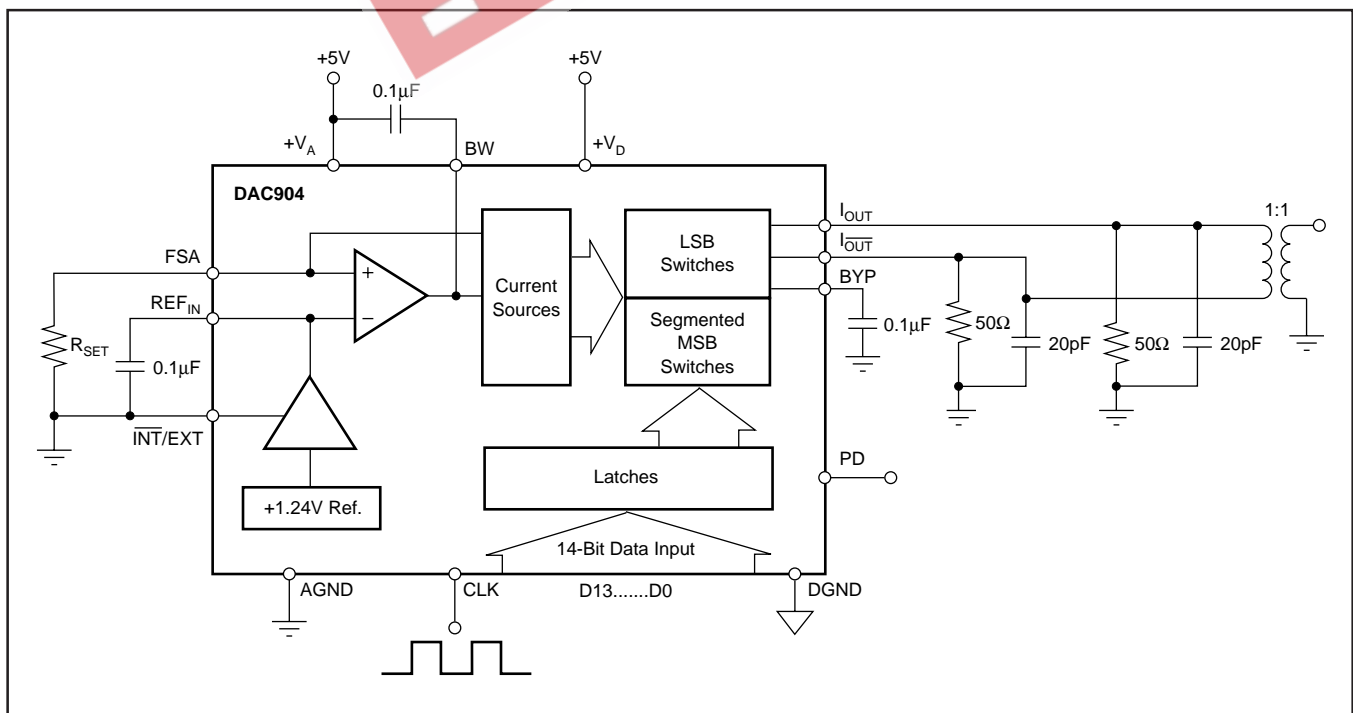

## TIMING DIAGRAM

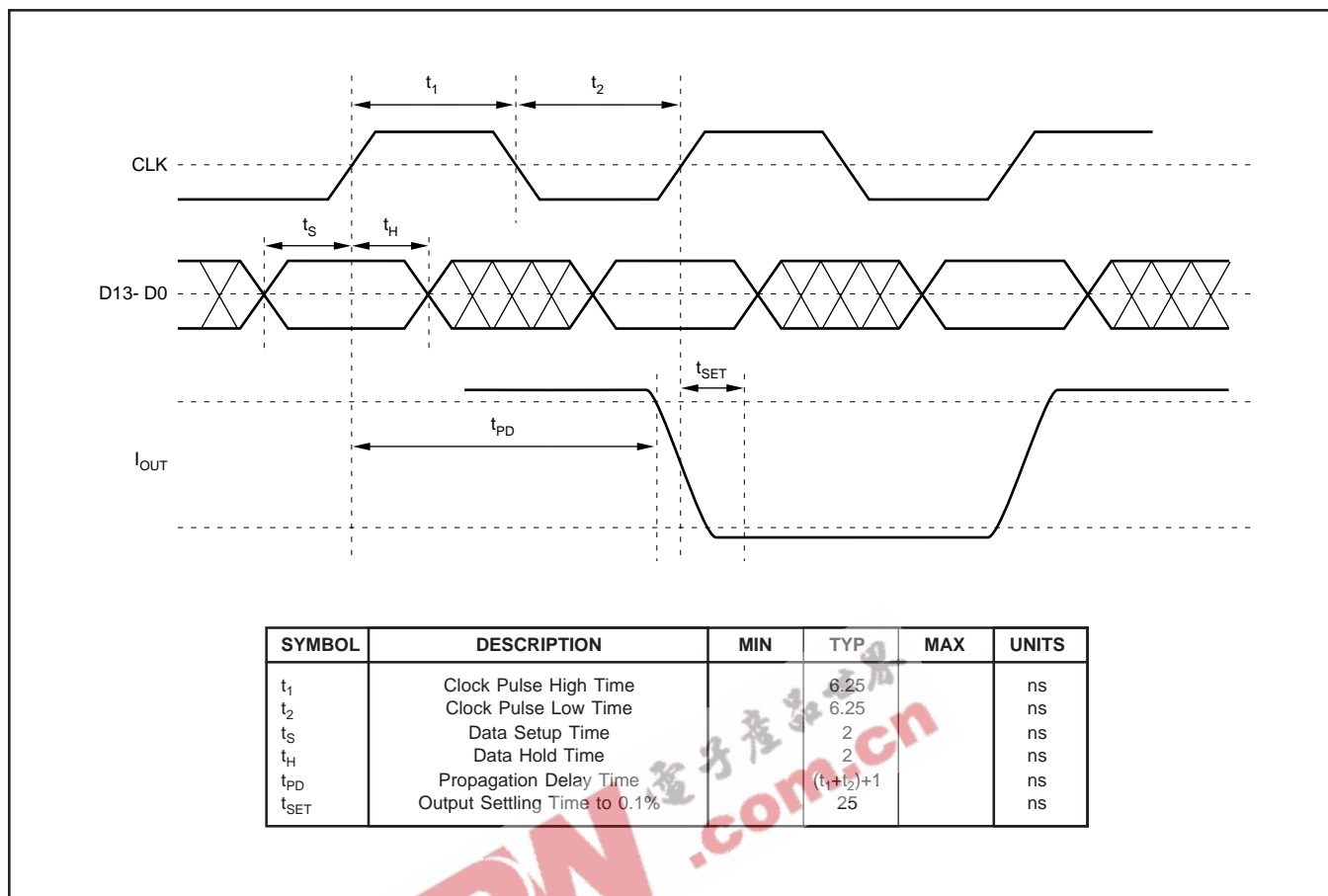

# TYPICAL PERFORMANCE CURVES, $V_D = V_A = +5V$

At  $T_A = +25^\circ C$ , Differential  $I_{OUT} = 20mA$ ,  $50\Omega$  double-terminated load, SFDR up to Nyquist, unless otherwise specified.

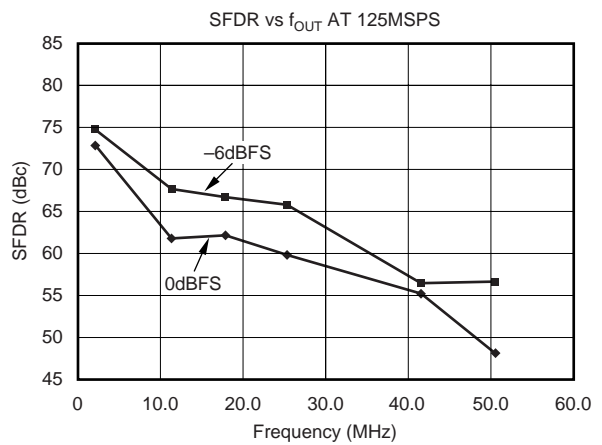
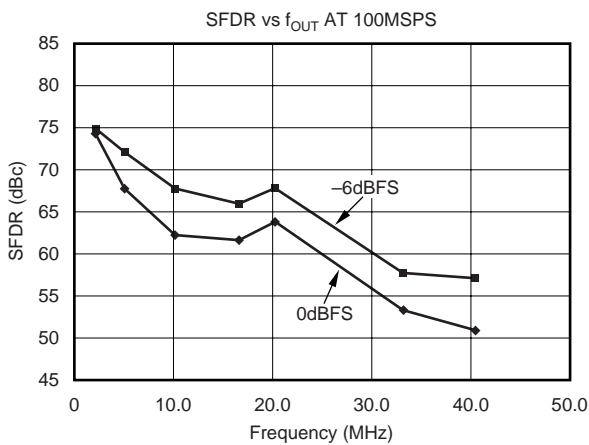
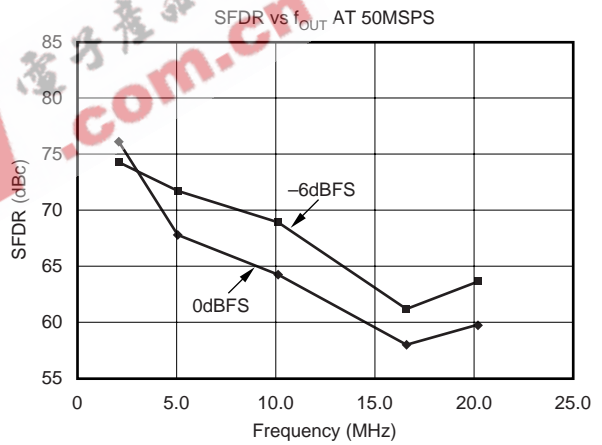
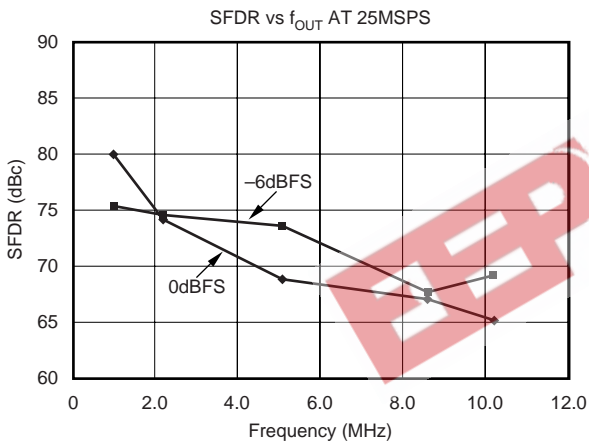
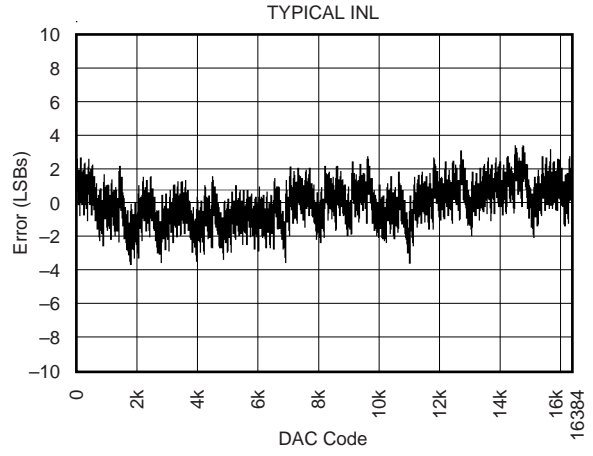
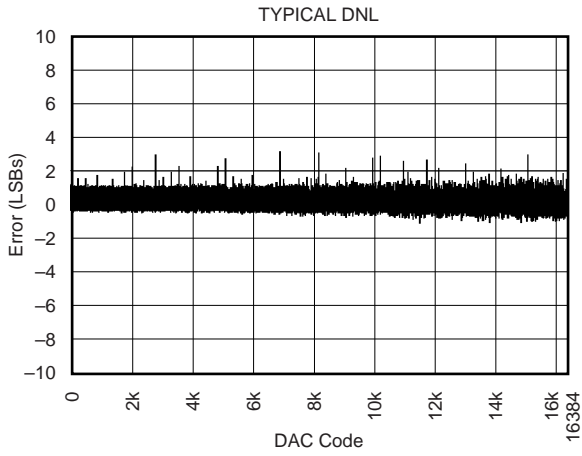

# TYPICAL PERFORMANCE CURVES, $V_D = V_A = +5V$ (Cont.)

At  $T_A = +25^\circ C$ , Differential  $I_{OUT} = 20mA$ ,  $50\Omega$  double-terminated load, SFDR up to Nyquist, unless otherwise specified.

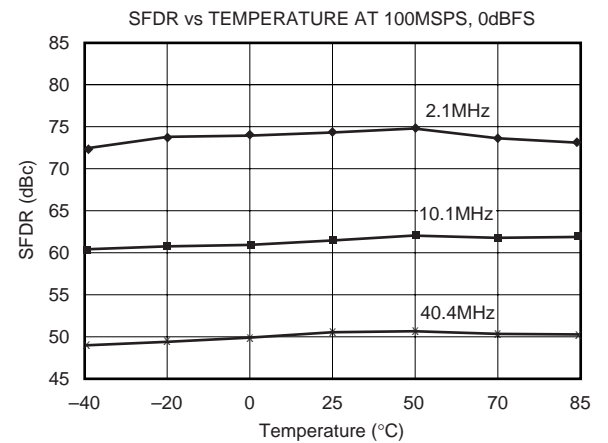
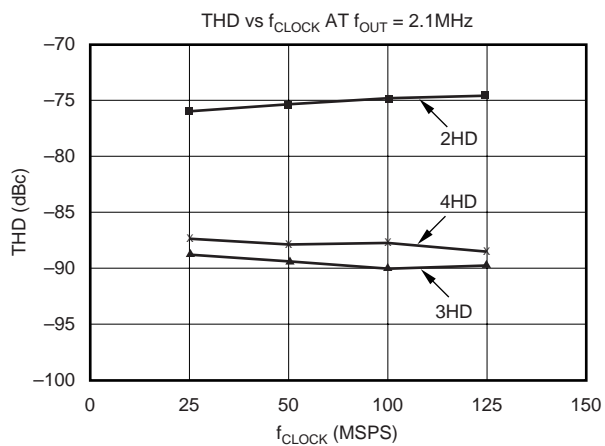
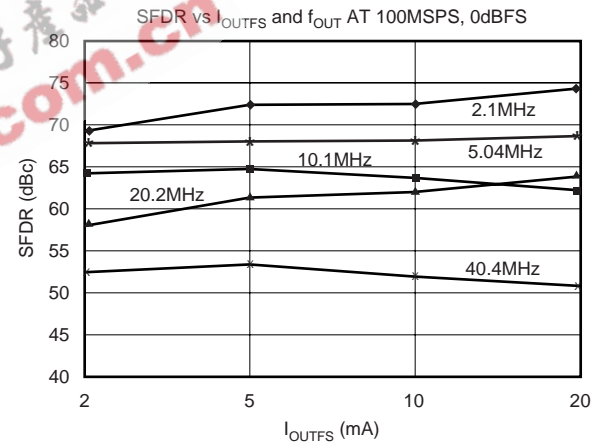
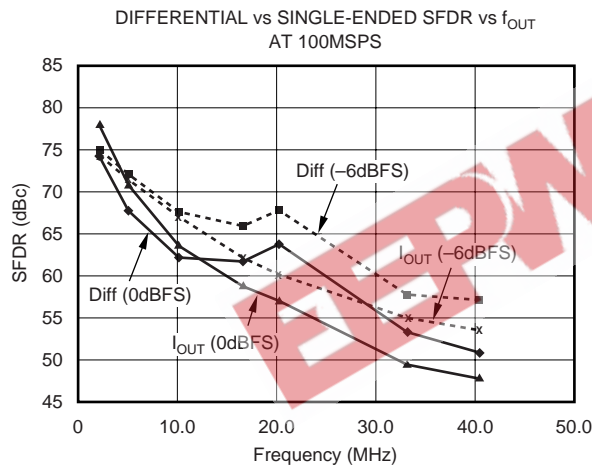
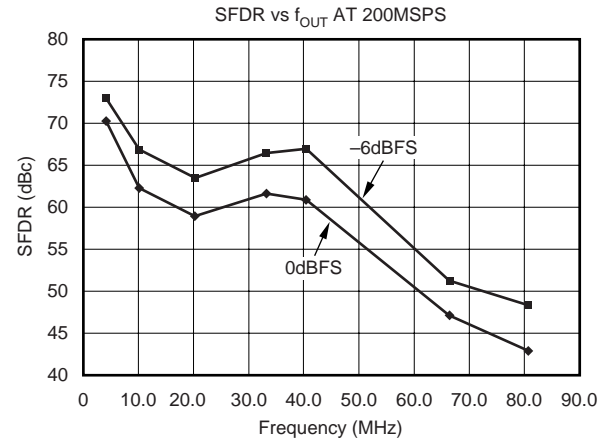
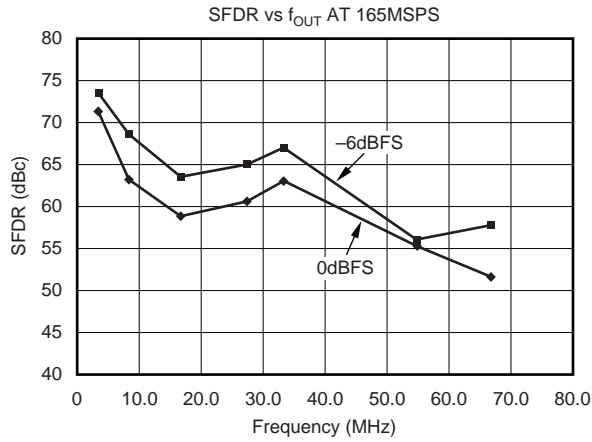

# TYPICAL PERFORMANCE CURVES, $V_D = V_A = +5V$ (Cont.)

At  $T_A = +25^\circ\text{C}$ , Differential  $I_{OUT} = 20\text{mA}$ ,  $50\Omega$  double-terminated load, SFDR up to Nyquist, unless otherwise specified.

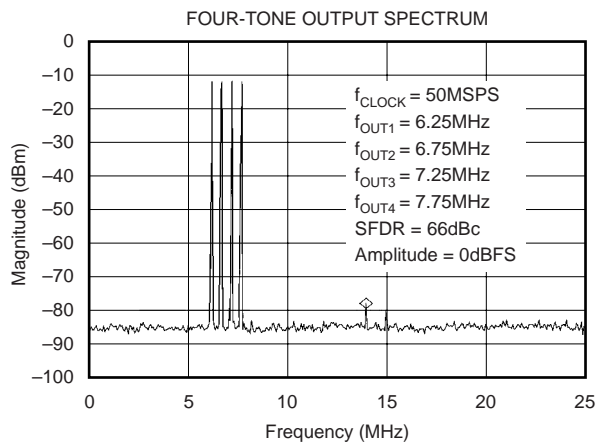
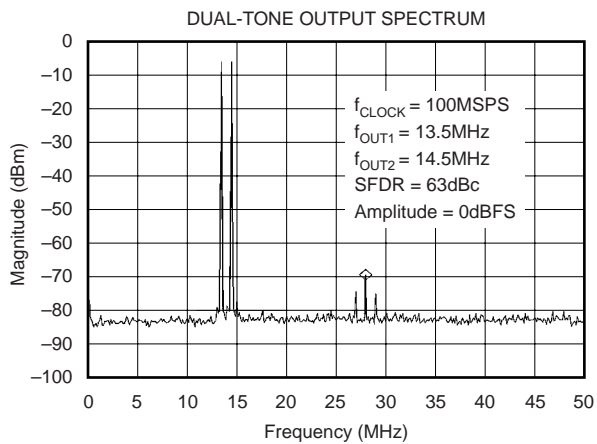

EEPW 电子产品世界 .com.cn



# TYPICAL PERFORMANCE CURVES, $V_D = V_A = +3V$

At  $T_A = +25^\circ C$ , Differential  $I_{OUT} = 20mA$ ,  $50\Omega$  double-terminated load, SFDR up to Nyquist, unless otherwise specified.

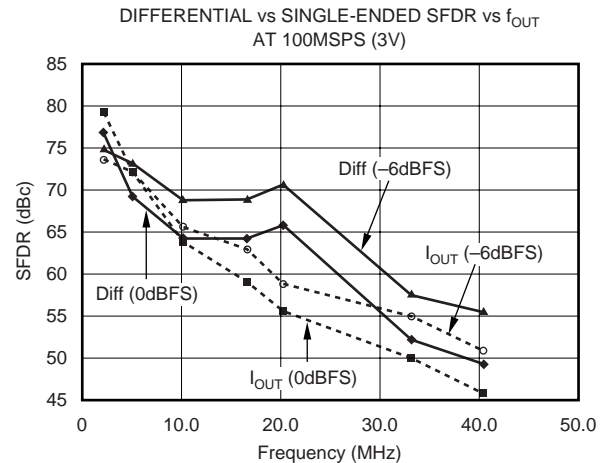
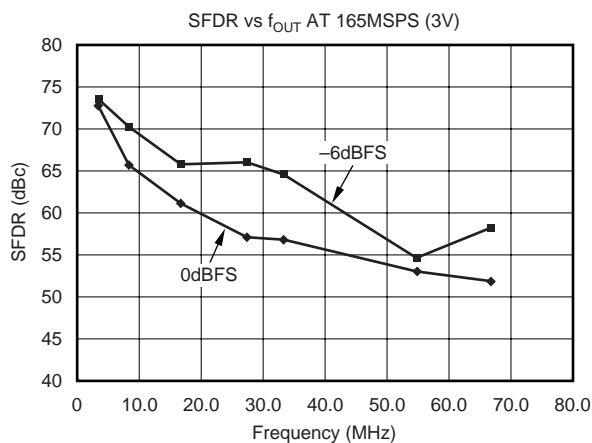
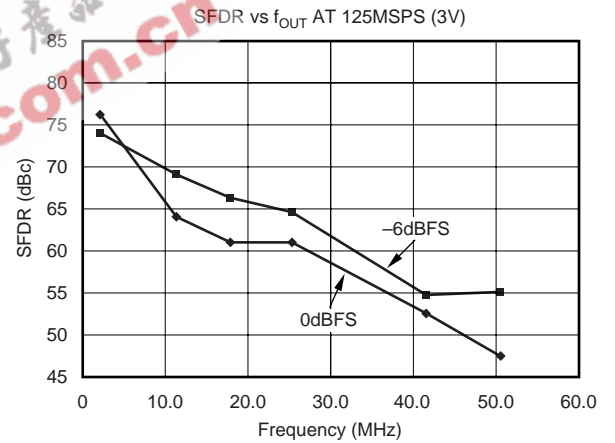
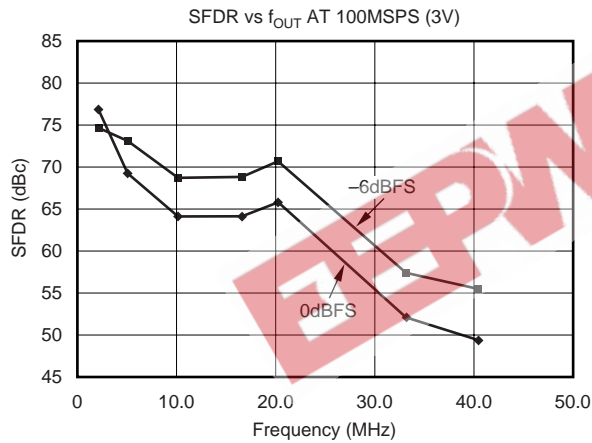
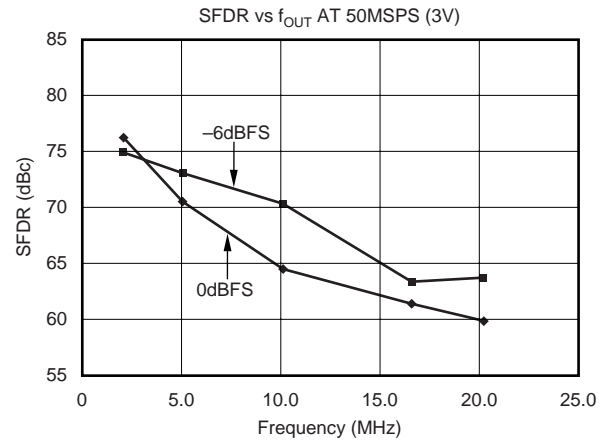
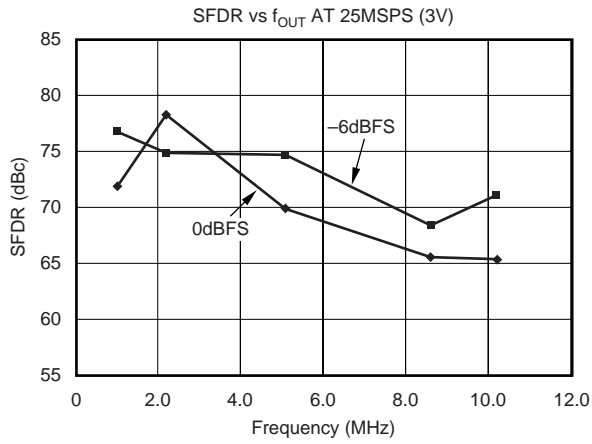

# TYPICAL PERFORMANCE CURVES, $V_D = V_A = +3V$ (Cont.)

At  $T_A = +25^\circ C$ , Differential  $I_{OUT} = 20mA$ ,  $50\Omega$  double-terminated load, SFDR up to Nyquist, unless otherwise specified.

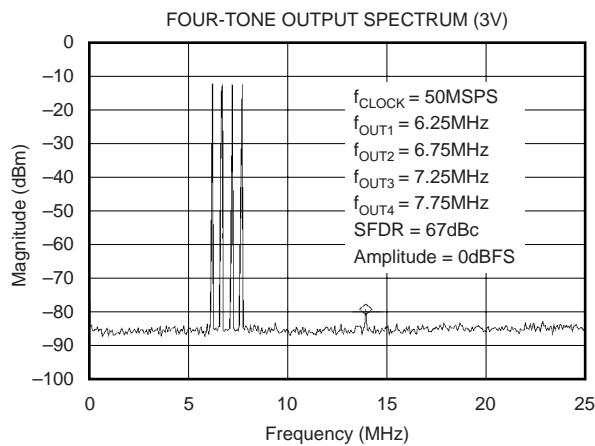
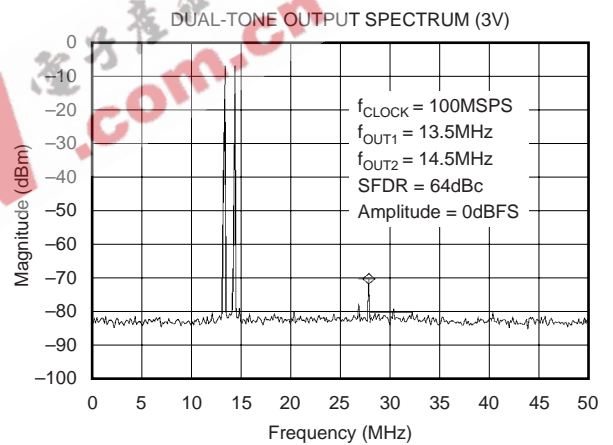
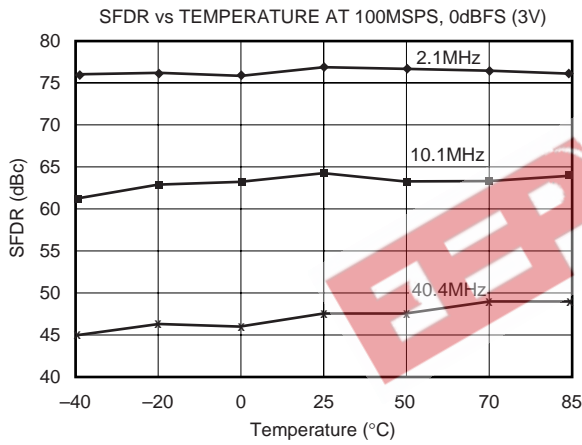
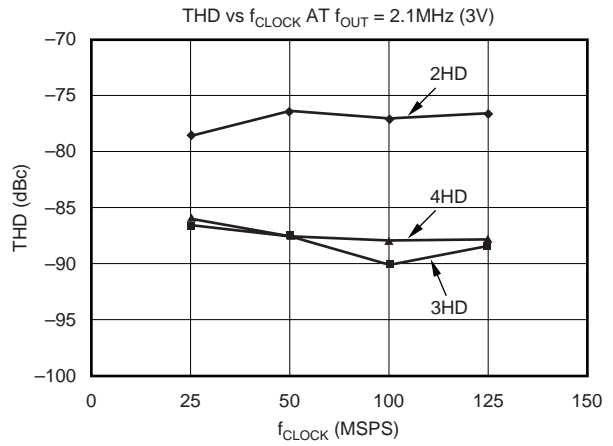
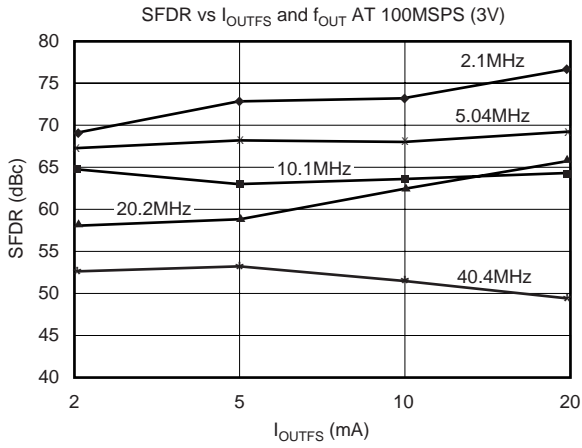

# APPLICATION INFORMATION

## THEORY OF OPERATION

The architecture of the DAC904 uses the current steering technique to enable fast switching and a high update rate. The core element within the monolithic D/A converter is an array of segmented current sources, which are designed to deliver a full-scale output current of up to 20mA (see Figure 1). An internal decoder addresses the differential current switches each time the DAC is updated and a corresponding output current is formed by steering all currents to either output summing node,  $I_{OUT}$  or  $I_{\overline{OUT}}$ . The complementary outputs deliver a differential output signal, which improves the dynamic performance through reduction of even-order harmonics, common-mode signals (noise), and double the peak-to-peak output signal swing by a factor of two, compared to single-ended operation.

The segmented architecture results in a significant reduction of the glitch energy, and improves the dynamic performance (SFDR) and DNL. The current outputs maintain a very high output impedance of greater than 200k $\Omega$ .

The full-scale output current is determined by the ratio of the internal reference voltage (1.24V) and an external resistor,  $R_{SET}$ . The resulting  $I_{REF}$  is internally multiplied by a factor of 32 to produce an effective DAC output current that can range from 2mA to 20mA, depending on the value of  $R_{SET}$ .

The DAC904 is split into a digital and an analog portion, each of which is powered through its own supply pin. The digital section includes edge-triggered input latches and the decoder logic, while the analog section comprises the current source array with its associated switches and the reference circuitry.

## DAC TRANSFER FUNCTION

The total output current,  $I_{OUTFS}$ , of the DAC904 is the summation of the two complementary output currents:

$$I_{OUTFS} = I_{OUT} + I_{\overline{OUT}} \quad (1)$$

The individual output currents depend on the DAC code and can be expressed as:

$$I_{OUT} = I_{OUTFS} \cdot (\text{Code}/16384) \quad (2)$$

$$I_{\overline{OUT}} = I_{OUTFS} \cdot (16383 - \text{Code}/16384) \quad (3)$$

where 'Code' is the decimal representation of the DAC data input word. Additionally,  $I_{OUTFS}$  is a function of the reference current  $I_{REF}$ , which is determined by the reference voltage and the external setting resistor,  $R_{SET}$ .

$$I_{OUTFS} = 32 \cdot I_{REF} = 32 \cdot V_{REF}/R_{SET} \quad (4)$$

In most cases the complementary outputs will drive resistive loads or a terminated transformer. A signal voltage will develop at each output according to:

$$V_{OUT} = I_{OUT} \cdot R_{LOAD} \quad (5)$$

$$V_{\overline{OUT}} = I_{\overline{OUT}} \cdot R_{LOAD} \quad (6)$$

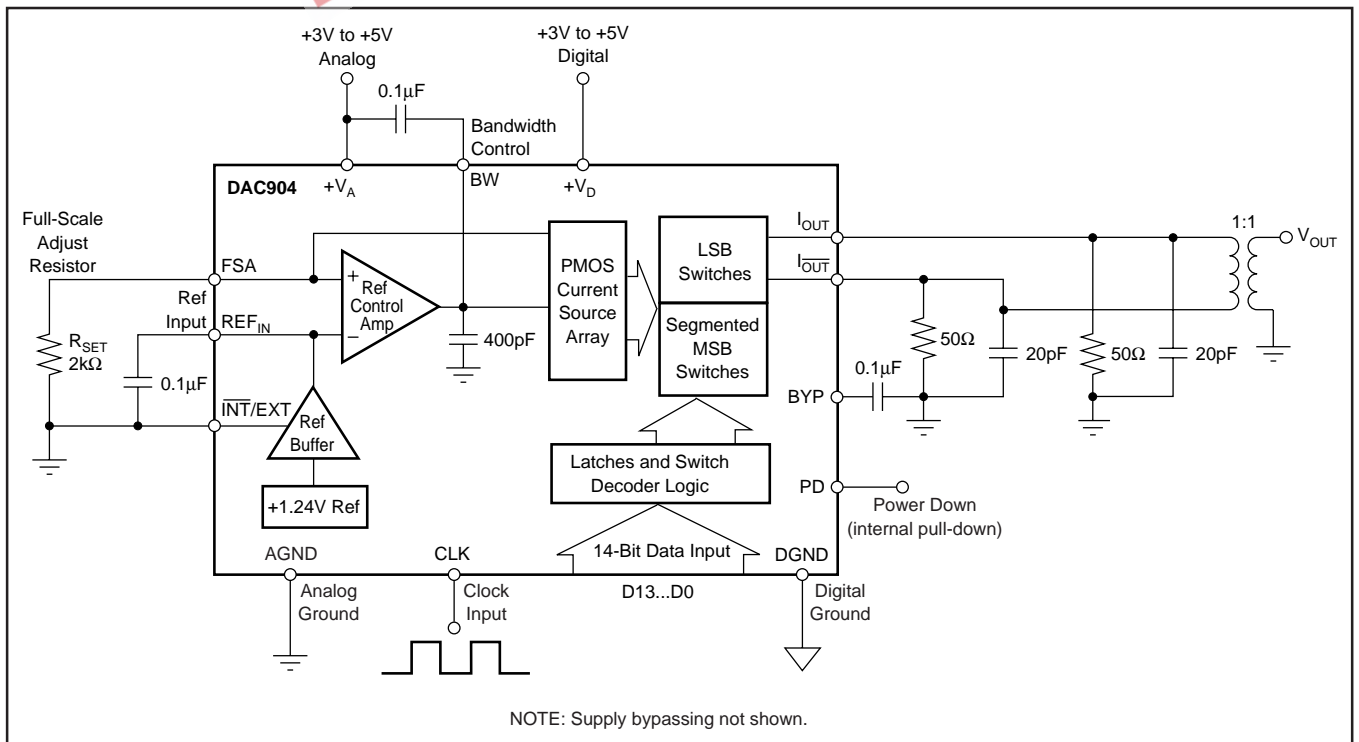

FIGURE 1. Functional Block Diagram of the DAC904.

The value of the load resistance is limited by the output compliance specification of the DAC904. To maintain specified linearity performance, the voltage for  $I_{OUT}$  and  $I_{OUT}$  should not exceed the maximum allowable compliance range.

The two single-ended output voltages can be combined to find the total differential output swing:

$$V_{OUTDIFF} = V_{OUT} - V_{OUT} = \frac{(2 \cdot \text{Code} - 16383)}{16384} \cdot I_{OUTFS} \cdot R_{LOAD} \quad (7)$$

## ANALOG OUTPUTS

The DAC904 provides two complementary current outputs,  $I_{OUT}$  and  $I_{OUT}$ . The simplified circuit of the analog output stage representing the differential topology is shown in Figure 2. The output impedance of  $200k\Omega \parallel 12pF$  for  $I_{OUT}$  and  $I_{OUT}$  results from the parallel combination of the differential switches, along with the current sources and associated parasitic capacitances.

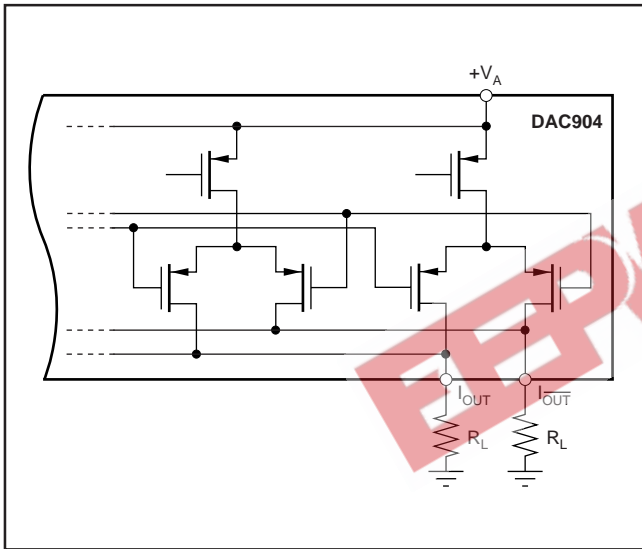

FIGURE 2. Equivalent Analog Output.

The signal voltage swing that may develop at the two outputs,  $I_{OUT}$  and  $I_{OUT}$ , is limited by a negative and positive compliance. The negative limit of  $-1V$  is given by the breakdown voltage of the CMOS process, and exceeding it will compromise the reliability of the DAC904, or even cause permanent damage. With the full-scale output set to  $20mA$ , the positive compliance equals  $1.25V$ , operating with  $+V_D = 5V$ . Note that the compliance range decreases to about  $1V$  for a selected output current of  $I_{OUTFS} = 2mA$ . Care should be taken that the configuration of DAC904 does not exceed the compliance range to avoid degradation of the distortion performance and integral linearity.

Best distortion performance is typically achieved with the maximum full-scale output signal limited to approximately  $0.5V$ . This is the case for a  $50\Omega$  doubly terminated load and a  $20mA$  full-scale output current. A variety of loads can be adapted to the output of the DAC904 by selecting a suitable transformer while maintaining optimum voltage levels at

$I_{OUT}$  and  $I_{OUT}$ . Furthermore, using the differential output configuration in combination with a transformer will be instrumental for achieving excellent distortion performance. Common-mode errors, such as even-order harmonics or noise, can be substantially reduced. This is particularly the case with high output frequencies and/or output amplitudes below full-scale.

For those applications requiring the optimum distortion and noise performance, it is recommended to select a full-scale output of  $20mA$ . A lower full-scale range down to  $2mA$  may be considered for applications that require a low power consumption, but can tolerate a reduced performance level.

INPUT CODE (D13 - D0)	$I_{OUT}$	$I_{OUT}$
11 1111 1111 1111	20mA	0mA
10 0000 0000 0000	10mA	10mA
00 0000 0000 0000	0mA	20mA

Table I. Input Coding vs Analog Output Current.

## OUTPUT CONFIGURATIONS

The current output of the DAC904 allows for a variety of configurations, some of which are illustrated below. As mentioned previously, utilizing the converter's differential outputs will yield the best dynamic performance. Such a differential output circuit may consist of an RF transformer (see Figure 3) or a differential amplifier configuration (see Figure 4). The transformer configuration is ideal for most applications with ac coupling, while op amps will be suitable for a dc-coupled configuration.

The single-ended configuration (see Figure 6) may be considered for applications requiring a unipolar output voltage. Connecting a resistor from either one of the outputs to ground will convert the output current into a ground-referenced voltage signal. To improve on the dc linearity an I to V converter can be used instead. This will result in a negative signal excursion and, therefore, requires a dual supply amplifier.

## DIFFERENTIAL WITH TRANSFORMER

Using an RF transformer provides a convenient way of converting the differential output signal into a single-ended signal while achieving excellent dynamic performance (see Figure 3). The appropriate transformer should be carefully selected based on the output frequency spectrum and impedance requirements. The differential transformer configuration has the benefit of significantly reducing common-mode signals, thus improving the dynamic performance over a wide range of frequencies. Furthermore, by selecting a suitable impedance ratio (winding ratio), the transformer can be used to provide optimum impedance matching while controlling the compliance voltage for the converter outputs. The model shown, ADT1-1WT (by Mini-Circuits), has a 1:1 ratio and may be used to interface the DAC904 to a  $50\Omega$  load. This results in a  $25\Omega$  load for each of the outputs,  $I_{OUT}$  and  $I_{OUT}$ . The output signals are ac coupled and inherently isolated because of the transformer's magnetic coupling.

As shown in Figure 3, the transformer's center tap is connected to ground. This forces the voltage swing on  $I_{OUT}$  and  $I_{\overline{OUT}}$  to be centered at 0V. In this case the two resistors,  $R_S$ , may be replaced with one,  $R_{DIFF}$ , or omitted altogether. This approach should only be used if all components are close to each other, and if the VSWR is not important. A complete power transfer from the DAC output to the load can be realized, but the output compliance range should be observed. Alternatively, if the center tap is not connected, the signal swing will be centered at  $R_S \cdot I_{OUTFS}/2$ . However, in this case, the two resistors,  $R_S$ , must be used to enable the necessary dc-current flow for both outputs.

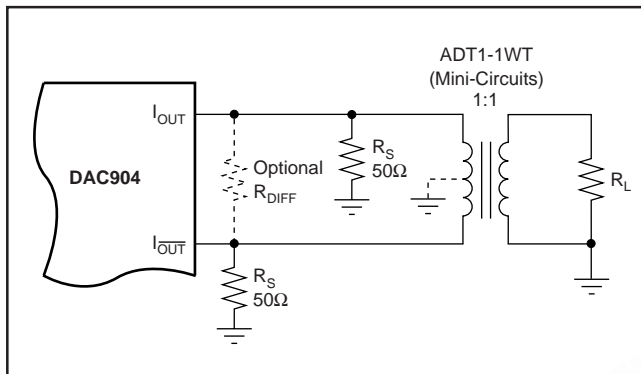

FIGURE 3. Differential Output Configuration Using an RF Transformer.

### DIFFERENTIAL CONFIGURATION USING AN OP AMP

If the application requires a dc-coupled output, a difference amplifier may be considered, as shown in Figure 4. Four external resistors are needed to configure the voltage-feedback op amp OPA680 as a difference amplifier performing the differential to single-ended conversion. Under the shown configuration, the DAC904 generates a differential output signal of 0.5Vp-p at the load resistors,  $R_L$ . The resistor values shown were selected to result in a symmetric 25Ω loading for each of the current outputs since the input impedance of the difference amplifier is in parallel to resistors  $R_L$ , and should be considered.

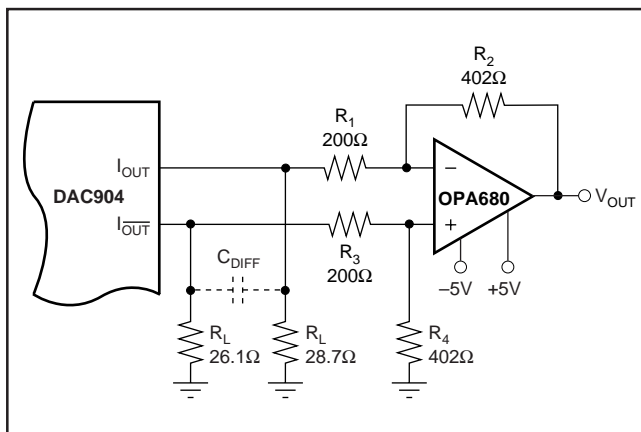

FIGURE 4. Difference Amplifier Provides Differential to Single-Ended Conversion and AC-Coupling.

The OPA680 is configured for a gain of two. Therefore, operating the DAC904 with a 20mA full-scale output will produce a voltage output of  $\pm 1V$ . This requires the amplifier to operate off of a dual power supply ( $\pm 5V$ ). The tolerance of the resistors typically sets the limit for the achievable common-mode rejection. An improvement can be obtained by fine tuning resistor  $R_4$ .

This configuration typically delivers a lower level of ac performance than the previously discussed transformer solution because the amplifier introduces another source of distortion. Suitable amplifiers should be selected based on their slew-rate, harmonic distortion, and output swing capabilities. High-speed amplifiers like the OPA680 or OPA687 may be considered. The ac performance of this circuit may be improved by adding a small capacitor,  $C_{DIFF}$ , between the outputs  $I_{OUT}$  and  $I_{\overline{OUT}}$ , as shown in Figure 4. This will introduce a real pole to create a low-pass filter in order to slew-limit the DACs fast output signal steps, which otherwise could drive the amplifier into slew-limitations or into an overload condition; both would cause excessive distortion. The difference amplifier can easily be modified to add a level shift for applications requiring the single-ended output voltage to be unipolar, i.e., swing between 0V and +2V.

### DUAL TRANSMIMPEDANCE OUTPUT CONFIGURATION

The circuit example of Figure 5 shows the signal output currents connected into the summing junction of the OPA2680, which is set up as a transimpedance stage, or 'I to V converter'. With this circuit, the DAC's output will be kept at a virtual ground, minimizing the effects of output impedance variations, and resulting in the best dc linearity (INL). However, as mentioned previously, the amplifier may be driven into slew-rate limitations, and produce unwanted distortion. This may occur, especially, at high DAC update rates.

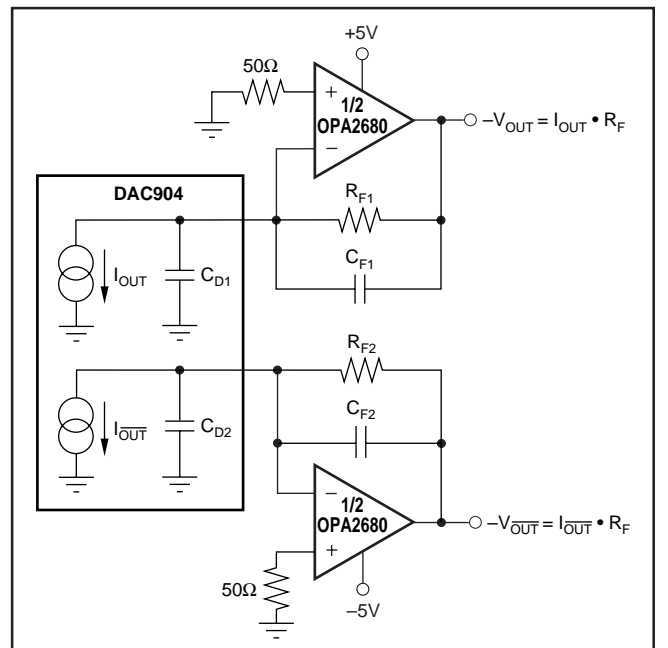

FIGURE 5. Dual, Voltage-Feedback Amplifier OPA2680 Forms Differential Transimpedance Amplifier.

The DC gain for this circuit is equal to feedback resistor  $R_F$ . At high frequencies, the DAC output impedance ( $C_{D1}$ ,  $C_{D2}$ ) will produce a zero in the noise gain for the OPA2680 that may cause peaking in the closed-loop frequency response.  $C_F$  is added across  $R_F$  to compensate for this noise gain peaking. To achieve a flat transimpedance frequency response, the pole in each feedback network should be set to:

$$\frac{1}{2\pi R_F C_F} = \frac{\sqrt{GBP}}{4\pi R_F C_D} \quad (8)$$

with  $GBP = \text{Gain Bandwidth Product of OPA}$

which will give a corner frequency  $f_{-3dB}$  of approximately:

$$f_{-3dB} = \frac{\sqrt{GBP}}{2\pi R_F C_D} \quad (9)$$

The full-scale output voltage is defined by the product of  $I_{OUTFS} \cdot R_F$ , and has a negative unipolar excursion. To improve on the ac performance of this circuit, adjustment of  $R_F$  and/or  $I_{OUTFS}$  should be considered. Further extensions of this application example may include adding a differential filter at the OPA2680's output followed by a transformer, in order to convert to a single-ended signal.

### SINGLE-ENDED CONFIGURATION

Using a single load resistor connected to the one of the DAC outputs, a simple current-to-voltage conversion can be accomplished. The circuit in Figure 6 shows a  $50\Omega$  resistor connected to  $I_{OUT}$ , providing the termination of the further connected  $50\Omega$  cable. Therefore, with a nominal output current of 20mA, the DAC produces a total signal swing of 0 to 0.5V into the  $25\Omega$  load.

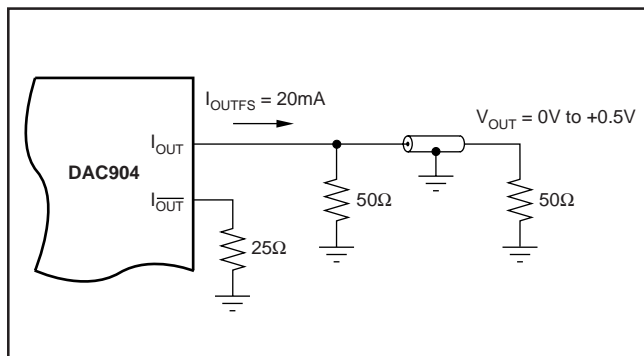

FIGURE 6. Driving a Doubly Terminated 50Ω Cable Directly.

Different load resistor values may be selected as long as the output compliance range is not exceeded. Additionally, the output current,  $I_{OUTFS}$ , and the load resistor, may be mutually adjusted to provide the desired output signal swing and performance.

### INTERNAL REFERENCE OPERATION

The DAC904 has an on-chip reference circuit which comprises a 1.24V bandgap reference and a control amplifier. Grounding of pin 16, INT/EXT, enables the internal reference operation. The full-scale output current,  $I_{OUTFS}$ , of the DAC904 is determined by the reference voltage,  $V_{REF}$ , and the value of resistor  $R_{SET}$ .  $I_{OUTFS}$  can be calculated by:

$$I_{OUTFS} = 32 \cdot I_{REF} = 32 \cdot V_{REF} / R_{SET} \quad (10)$$

As shown in Figure 7, the external resistor  $R_{SET}$  connects to the FSA pin (Full-Scale Adjust). The reference control amplifier operates as a V to I converter producing a reference current,  $I_{REF}$ , which is determined by the ratio of  $V_{REF}$  and  $R_{SET}$  (see Equation 10). The full-scale output current,  $I_{OUTFS}$ , results from multiplying  $I_{REF}$  by a fixed factor of 32.

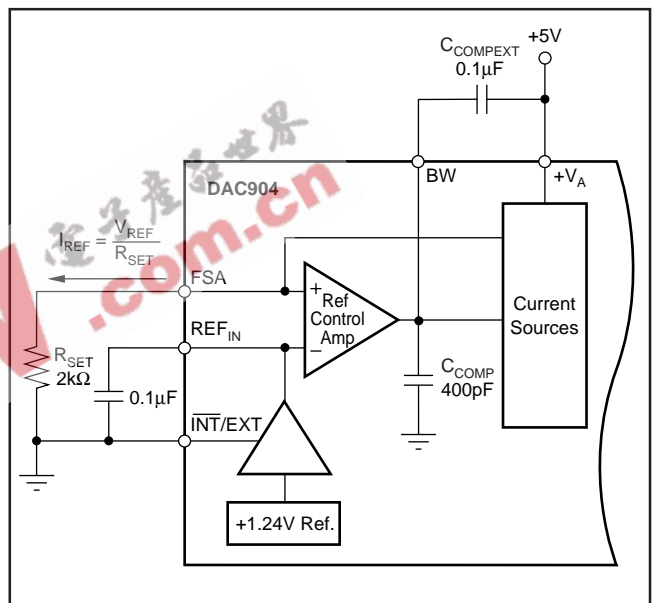

FIGURE 7. Internal Reference Configuration.

Using the internal reference, a  $2k\Omega$  resistor value results in a 20mA full-scale output. Resistors with a tolerance of 1% or better should be considered. Selecting higher values, the converter output can be adjusted from 20mA down to 2mA. Operating the DAC904 at lower than 20mA output currents may be desirable for reasons of reducing the total power consumption, improving the distortion performance, or observing the output compliance voltage limitations for a given load condition.

It is recommended to bypass the  $REF_{IN}$  pin with a ceramic chip capacitor of  $0.1\mu F$  or more. The control amplifier is internally compensated, and its small signal bandwidth is approximately 1.3MHz. To improve the ac performance, an additional capacitor ( $C_{COMPEXT}$ ) should be applied between the BW pin and the analog supply,  $+V_A$ , as shown in Figure 7. Using a  $0.1\mu F$  capacitor, the small-signal bandwidth and output impedance of the control amplifier is further diminished, reducing the noise that is fed into the current source array. This also helps shunting feedthrough signals more effectively, and improving the noise performance of the DAC904.

## EXTERNAL REFERENCE OPERATION

The internal reference can be disabled by applying a logic High (+V<sub>A</sub>) to pin INT/EXT. An external reference voltage can then be driven into the REF<sub>IN</sub> pin, which in this case functions as an input, as shown in Figure 8. The use of an external reference may be considered for applications that require higher accuracy and drift performance, or to add the ability of dynamic gain control.

While a 0.1μF capacitor is recommended to be used with the internal reference, it is optional for the external reference operation. The reference input, REF<sub>IN</sub>, has a high input impedance (1MΩ) and can easily be driven by various sources. Note that the voltage range of the external reference should stay within the compliance range of the reference input (0.1V to 1.25V).

## DIGITAL INPUTS

The digital inputs, D0 (LSB) through D13 (MSB) of the DAC904 accept standard positive binary coding. The digital input word is latched into a master-slave latch with the rising edge of the clock. The DAC output becomes updated with the following rising clock edge (refer to the specification table and timing diagram for details). The best performance will be achieved with a 50% clock duty cycle, however, the duty cycle may vary as long as the timing specifications are met. Additionally, the setup and hold times may be chosen within their specified limits.

All digital inputs are CMOS compatible. The logic thresholds depend on the applied digital supply voltage such that they are set to approximately half the supply voltage; V<sub>th</sub> = +VD/2 (±20% tolerance). The DAC904 is designed to operate over a supply range of 2.7V to 5.5V.

## POWER-DOWN MODE

The DAC904 features a power-down function which can be used to reduce the supply current to less than 9mA over the specified supply range of 2.7V to 5.5V. Applying a logic High to the PD pin will initiate the power-down mode, while a logic Low enables normal operation. When left unconnected, an internal active pull-down circuit will enable the normal operation of the converter.

## GROUNDING, DECOUPLING AND LAYOUT INFORMATION

Proper grounding and bypassing, short lead length, and the use of ground planes are particularly important for high frequency designs. Multilayer pc-boards are recommended for best performance since they offer distinct advantages such as minimization of ground impedance, separation of signal layers by ground layers, etc.

The DAC904 uses separate pins for its analog and digital supply and ground connections. The placement of the decoupling capacitor should be such that the analog supply (+V<sub>A</sub>) is bypassed to the analog ground (AGND), and the digital supply bypassed to the digital ground (DGND). In most cases 0.1μF ceramic chip capacitors at each supply pin are adequate to provide a low impedance decoupling path. Keep in mind that their effectiveness largely depends on the proximity to the individual supply and ground pins. Therefore they should be located as close as physically possible to those device leads. Whenever possible, the capacitors should be located immediately under each pair of supply/ground pins on the reverse side of the pc board. This layout approach will minimize the parasitic inductance of component leads and pcb runs.

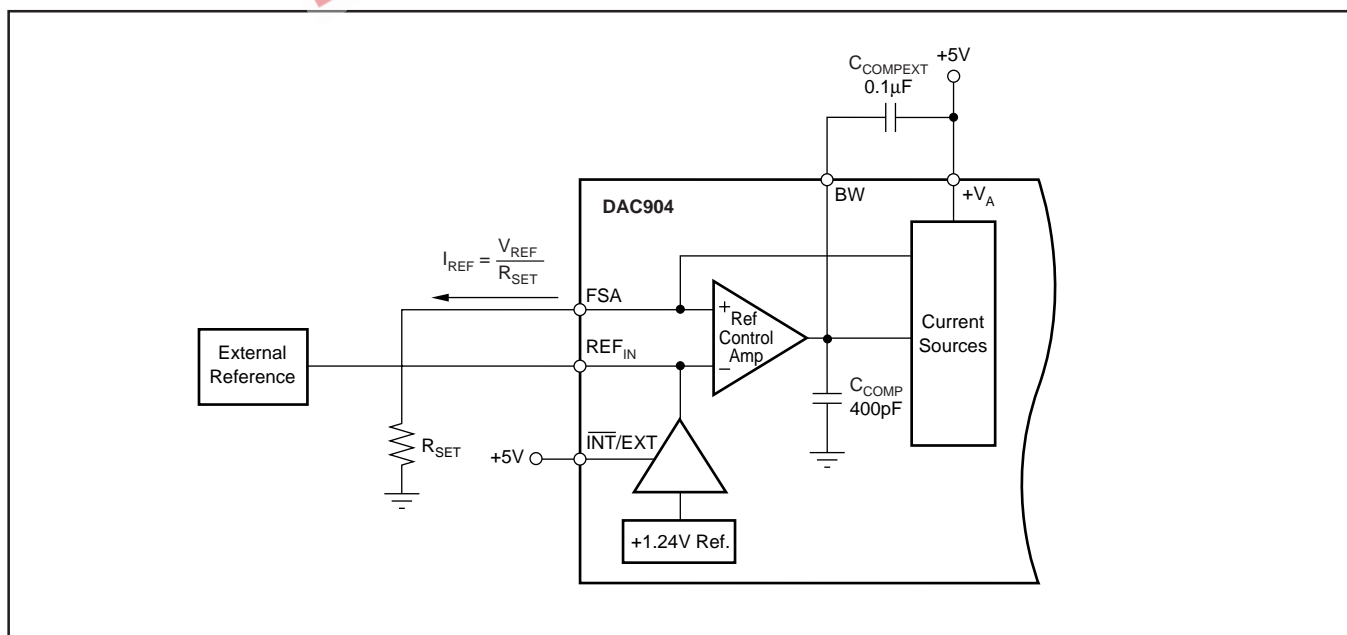

FIGURE 8. External Reference Configuration.

Further supply decoupling with surface mount tantalum capacitors (1uF to 4.7uF) may be added as needed in proximity of the converter.

Low noise is required for all supply and ground connections to the DAC904. It is recommended to use a multilayer pc-board utilizing separate power and ground planes. Mixed signal designs require particular attention to the routing of the different supply currents and signal traces. Generally, analog supply and ground planes should only extend into analog signal areas, such as the DAC output signal and the reference signal. Digital supply and ground planes must be confined to areas covering digital circuitry, including the digital input lines connecting to the converter, as well as the clock signal. The analog and digital ground planes should be joined together at one point underneath the D/A converter. This can be realized with a short track of approximately 1/8inch (3mm).

The power to the DAC904 should be provided through the use of wide pcb runs or planes. Wide runs will present a lower trace impedance, further optimizing the supply decoupling. The analog and digital supplies for the converter should only be connected together at the supply connector of the pc board. In the case of only one supply voltage being available to power the DAC, ferrite beads along with bypass capacitors may be used to create an LC filter. This will generate a low noise analog supply voltage, which can then be connected to the +V<sub>A</sub> supply pin of the DAC904.

While designing the layout, it is important to keep the analog signal traces separated from any digital line, in order to prevent noise coupling onto the analog signal path.

EEPW 电子产品世界  
.com.cn