

# Series DC780

## High Current Power Line Chokes

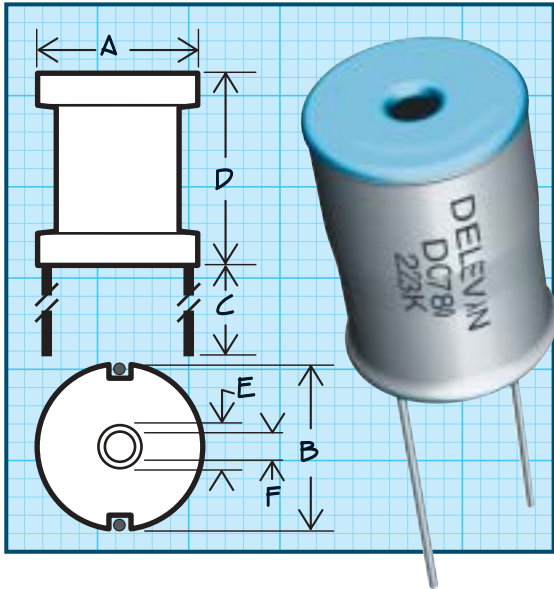

### Physical Parameters

	Inches	Millimeters
A	0.775 ± 0.025	19.6 ± 0.6
B (C/L to C/L)	See Characteristics table	
C	0.750 Min.	19.05 Min.
D	0.815 ± 0.015	20.7 ± 4
E (Ref. only)	0.195 Max.	4.95 Max.
F	Clearance Hole for 4/40 Screw	

**Leads** Tinned to within 1/16" of Body

**Inductance** Measured @ 1 KHz with 0 Amps dc

**Mechanical Configuration** Ferrite Bobbin protected with a flame retardant polyolefin sleeve; center hole allows for mechanical mounting; insulated bobbins.

### Operating Temperature

-55°C to +125°C;

-55°C to +80°C @ full rated current

**Current Rating at 80°C Ambient** 45°C Rise

**Incremental Current** Minimum current which causes a 5% max. change in Inductance

**Power Dissipation at 80°C** 1.400 Watts Max.

**Dielectric Withstanding Voltage** 1000 V RMS Min.

**Marking** Parts printed with DELEVAN and API Part Number

**Packaging** Bulk only

PART NUMBER	NOMINAL INDUCTANCE (µH)	TOLERANCE	DC RESISTANCE MAX. (OHMS) @ 25°C	CURRENT RATING MAXIMUM (A DC)	INCREMENTAL CURRENT (A DC)	DIMENSION B (Approx. Inches)	LEAD DIAMETER (Inches)
SERIES DC 780							
DC780-102L	1.0	± 15%	0.003	11.4	110.0	0.620	0.051
DC780-122L	1.2	± 15%	0.003	11.4	108.0	0.620	0.051
DC780-152L	1.5	± 15%	0.003	11.4	89.0	0.620	0.051
DC780-182L	1.8	± 15%	0.003	11.4	81.0	0.620	0.051
DC780-222L	2.2	± 15%	0.004	11.4	73.0	0.620	0.051
DC780-272L	2.7	± 15%	0.005	11.4	66.0	0.620	0.051
DC780-332L	3.3	± 15%	0.005	11.4	60.0	0.620	0.051
DC780-392L	3.9	± 15%	0.005	11.4	55.0	0.620	0.051
DC780-472L	4.7	± 15%	0.005	11.4	50.0	0.620	0.051
DC780-562L	5.6	± 15%	0.006	11.4	46.0	0.620	0.051
DC780-682L	6.8	± 15%	0.007	11.4	42.0	0.620	0.051
DC780-822L	8.2	± 15%	0.007	11.4	38.0	0.620	0.051
DC780-103K	10.0	± 10%	0.009	11.4	34.5	0.620	0.051
DC780-123K	12.0	± 10%	0.009	11.4	31.5	0.620	0.051
DC780-153K	15.0	± 10%	0.013	9.0	28.2	0.625	0.045
DC780-183K	18.0	± 10%	0.018	7.2	25.7	0.630	0.045
DC780-223K	22.0	± 10%	0.019	7.2	23.3	0.630	0.045
DC780-273K	27.0	± 10%	0.026	5.5	21.0	0.546	0.040
DC780-333K	33.0	± 10%	0.029	5.5	19.0	0.546	0.036
DC780-393K	39.0	± 10%	0.030	5.5	17.5	0.594	0.036
DC780-473K	47.0	± 10%	0.035	5.5	15.9	0.625	0.036
DC780-563K	56.0	± 10%	0.039	5.5	14.6	0.625	0.036
DC780-683K	68.0	± 10%	0.053	4.8	13.2	0.656	0.036
DC780-823K	82.0	± 10%	0.060	4.8	12.1	0.656	0.036
DC780-104K	100	± 10%	0.080	4.0	10.9	0.593	0.036
DC780-124K	120	± 10%	0.090	4.0	10.0	0.593	0.036
DC780-154K	150	± 10%	0.098	4.0	8.9	0.593	0.032
DC780-184K	180	± 10%	0.110	4.0	8.1	0.593	0.032
DC780-224K	220	± 10%	0.150	2.8	7.4	0.593	0.029
DC780-274K	270	± 10%	0.213	2.0	6.6	0.562	0.025
DC780-334K	330	± 10%	0.305	1.6	6.0	0.590	0.025
DC780-394K	390	± 10%	0.320	1.6	5.5	0.590	0.025
DC780-474K	470	± 10%	0.355	1.6	5.0	0.590	0.025
DC780-564K	560	± 10%	0.388	1.6	4.6	0.590	0.023
DC780-684K	680	± 10%	0.430	1.6	4.2	0.590	0.023
DC780-824K	820	± 10%	0.590	1.3	3.8	0.590	0.023
DC780-105K	1,000	± 10%	0.818	1.0	3.5	0.590	0.020
DC780-125K	1,200	± 10%	1.140	0.8	3.2	0.590	0.018
DC780-155K	1,500	± 10%	1.260	0.8	2.8	0.590	0.018
DC780-185K	1,800	± 10%	1.390	0.8	2.6	0.590	0.018
DC780-225K	2,200	± 10%	1.540	0.8	2.3	0.590	0.018