

## DM54LS373/DM74LS373, DM54LS374/DM74LS374 TRI-STATE® Octal D-Type Transparent Latches and Edge-Triggered Flip-Flops

### General Description

These 8-bit registers feature totem-pole TRI-STATE outputs designed specifically for driving highly-capacitive or relatively low-impedance loads. The high-impedance state and increased high-logic level drive provide these registers with the capability of being connected directly to and driving the bus lines in a bus-organized system without need for interface or pull-up components. They are particularly attractive for implementing buffer registers, I/O ports, bidirectional bus drivers, and working registers. (Continued)

### Features

- Choice of 8 latches or 8 D-type flip-flops in a single package
- TRI-STATE bus-driving outputs
- Full parallel-access for loading
- Buffered control inputs
- P-N-P inputs reduce D-C loading on data lines

### Connection Diagrams

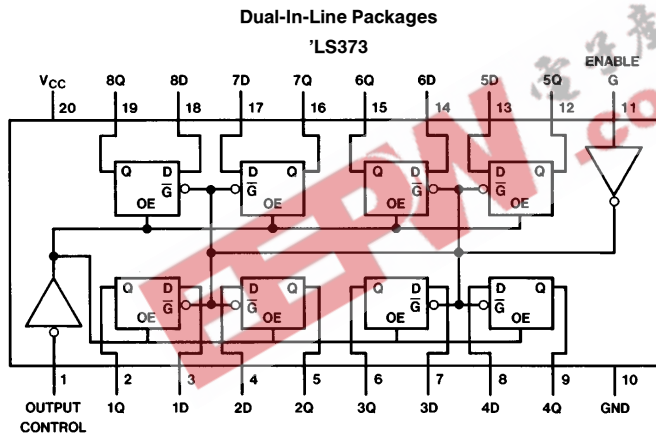

Order Number  
DM54LS373J,  
DM54LS373W,  
DM74LS373N or  
DM74LS373WM  
See NS Package Number  
J20A, M20B, N20A or  
W20A

TL/F/6431-1

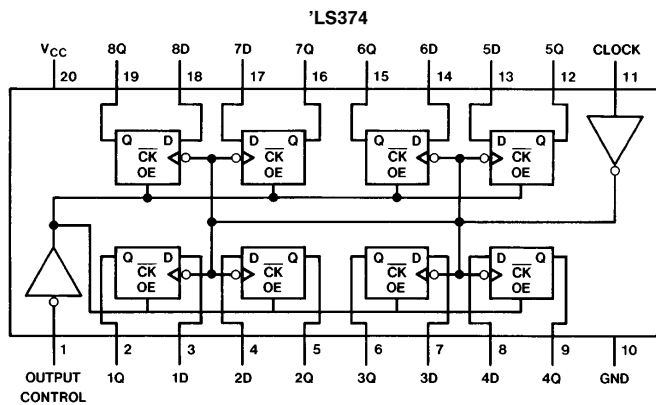

Order Number  
DM54LS374J,  
DM54LS374W,  
DM74LS374WM or  
DM74LS374N  
See NS Package Number  
J20A, M20B, N20A or  
W20A

TL/F/6431-2

TRI-STATE® is a registered trademark of National Semiconductor Corp.

## General Description (Continued)

The eight latches of the DM54/74LS373 are transparent D-type latches meaning that while the enable (G) is high the Q outputs will follow the data (D) inputs. When the enable is taken low the output will be latched at the level of the data that was set up.

The eight flip-flops of the DM54/74LS374 are edge-triggered D-type flip flops. On the positive transition of the clock, the Q outputs will be set to the logic states that were set up at the D inputs.

A buffered output control input can be used to place the eight outputs in either a normal logic state (high or low logic levels) or a high-impedance state. In the high-impedance state the outputs neither load nor drive the bus lines significantly.

The output control does not affect the internal operation of the latches or flip-flops. That is, the old data can be retained or new data can be entered even while the outputs are off.

## Function Tables

DM54/74LS373

Output Control	Enable G	D	Output
L	H	H	H
L	H	L	L
L	L	X	Q <sub>0</sub>
H	X	X	Z

DM54/74LS374

Output Control	Clock	D	Output
L	↑	H	H
L	↑	L	L
L	L	X	Q <sub>0</sub>
H	X	X	Z

H = High Level (Steady State), L = Low Level (Steady State), X = Don't Care  
 ↑ = Transition from low-to-high level, Z = High Impedance State  
 Q<sub>0</sub> = The level of the output before steady-state input conditions were established.

## Logic Diagrams

DM54/74LS373

Transparent Latches

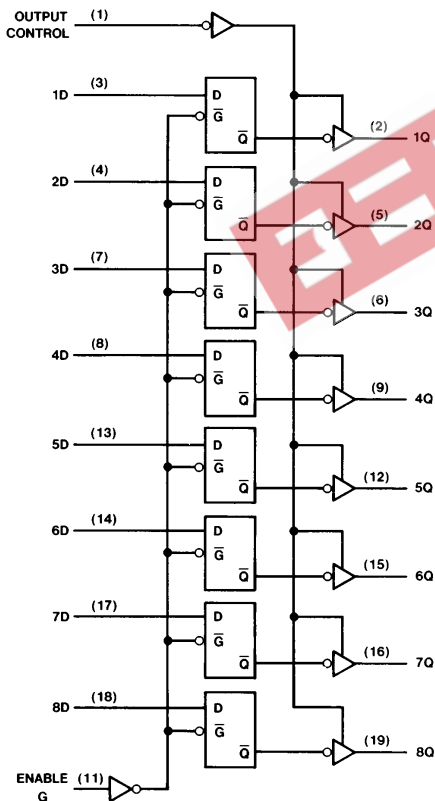

TL/F/6431-3

DM54/74LS374

Positive-Edge-Triggered Flip-Flops

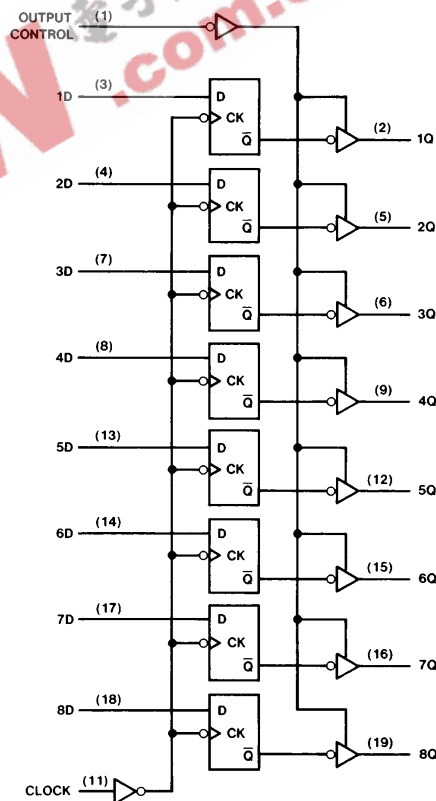

TL/F/6431-4

## Absolute Maximum Ratings (See Note)

If Military/Aerospace specified devices are required, please contact the National Semiconductor Sales Office/Distributors for availability and specifications.

Supply Voltage	7V
Input Voltage	7V
Storage Temperature Range	-65°C to +150°C
Operating Free Air Temperature Range	
DM54LS	-55°C to +125°C
DM74LS	0°C to +70°C

Note: The "Absolute Maximum Ratings" are those values beyond which the safety of the device cannot be guaranteed. The device should not be operated at these limits. The parametric values defined in the "Electrical Characteristics" table are not guaranteed at the absolute maximum ratings. The "Recommended Operating Conditions" table will define the conditions for actual device operation.

## Recommended Operating Conditions

Symbol	Parameter	DM54LS373			DM74LS373			Units
		Min	Nom	Max	Min	Nom	Max	
V <sub>CC</sub>	Supply Voltage	4.5	5	5.5	4.75	5	5.25	V
V <sub>IH</sub>	High Level Input Voltage	2			2			V
V <sub>IL</sub>	Low Level Input Voltage			0.7			0.8	V
I <sub>OH</sub>	High Level Output Current			-1			-2.6	mA
I <sub>OL</sub>	Low Level Output Current			12			24	mA
t <sub>w</sub>	Pulse Width (Note 2)	Enable High	15		15			ns
		Enable Low	15		15			
t <sub>SU</sub>	Data Setup Time (Notes 1 & 2)	5 ↓			5 ↓			ns
t <sub>H</sub>	Data Hold Time (Notes 1 & 2)	20 ↓			20 ↓			ns
T <sub>A</sub>	Free Air Operating Temperature	-55		125	0		70	°C

Note 1: The symbol (↓) indicates the falling edge of the clock pulse is used for reference.

Note 2: T<sub>A</sub> = 25°C and V<sub>CC</sub> = 5V.

## 'LS373 Electrical Characteristics

over recommended operating free air temperature range (unless otherwise noted)

Symbol	Parameter	Conditions	Min	Typ (Note 1)	Max	Units
V <sub>I</sub>	Input Clamp Voltage	V <sub>CC</sub> = Min, I <sub>I</sub> = -18 mA			-1.5	V
V <sub>OH</sub>	High Level Output Voltage	V <sub>CC</sub> = Min I <sub>OH</sub> = Max V <sub>IL</sub> = Max V <sub>IH</sub> = Min	DM54	2.4	3.4	V
			DM74	2.4	3.1	
V <sub>OL</sub>	Low Level Output Voltage	V <sub>CC</sub> = Min I <sub>OL</sub> = Max V <sub>IL</sub> = Max V <sub>IH</sub> = Min	DM54		0.25	V
			DM74		0.35	
		I <sub>OL</sub> = 12 mA V <sub>CC</sub> = Min	DM74			
I <sub>I</sub>	Input Current @ Max Input Voltage	V <sub>CC</sub> = Max, V <sub>I</sub> = 7V			0.1	mA
I <sub>IH</sub>	High Level Input Current	V <sub>CC</sub> = Max, V <sub>I</sub> = 2.7V			20	μA
I <sub>IL</sub>	Low Level Input Current	V <sub>CC</sub> = Max, V <sub>I</sub> = 0.4V			-0.4	mA
I <sub>OZH</sub>	Off-State Output Current with High Level Output Voltage Applied	V <sub>CC</sub> = Max, V <sub>O</sub> = 2.7V V <sub>IH</sub> = Min, V <sub>IL</sub> = Max			20	μA
I <sub>OZL</sub>	Off-State Output Current with Low Level Output Voltage Applied	V <sub>CC</sub> = Max, V <sub>O</sub> = 0.4V V <sub>IH</sub> = Min, V <sub>IL</sub> = Max			-20	μA
I <sub>OS</sub>	Short Circuit Output Current	V <sub>CC</sub> = Max (Note 2)	DM54	-20	-100	mA
			DM74	-50	-225	
I <sub>CC</sub>	Supply Current	V <sub>CC</sub> = Max, OC = 4.5V, D <sub>n</sub> , Enable = GND		24	40	mA

### 'LS373 Switching Characteristics at $V_{CC} = 5V$ and $T_A = 25^\circ C$

(See Section 1 for Test Waveforms and Output Load)

Symbol	Parameter	From (Input) To (Output)	$R_L = 667\Omega$				Units
			$C_L = 45\text{ pF}$		$C_L = 150\text{ pF}$		
			Min	Max	Min	Max	
$t_{PLH}$	Propagation Delay Time Low to High Level Output	Data to Q		18		26	ns
$t_{PHL}$	Propagation Delay Time High to Low Level Output	Data to Q		18		27	ns
$t_{PLH}$	Propagation Delay Time Low to High Level Output	Enable to Q		30		38	ns
$t_{PHL}$	Propagation Delay Time High to Low Level Output	Enable to Q		30		36	ns
$t_{PZH}$	Output Enable Time to High Level Output	Output Control to Any Q		28		36	ns
$t_{PZL}$	Output Enable Time to Low Level Output	Output Control to Any Q		36		50	ns
$t_{PHZ}$	Output Disable Time from High Level Output (Note 3)	Output Control to Any Q	20				ns
$t_{PLZ}$	Output Disable Time from Low Level Output (Note 3)	Output Control to Any Q	25				ns

**Note 1:** All typicals are at  $V_{CC} = 5V$ ,  $T_A = 25^\circ C$ .

**Note 2:** Not more than one output should be shorted at a time, and the duration should not exceed one second.

**Note 3:**  $C_L = 5\text{ pF}$ .

### Recommended Operating Conditions

Symbol	Parameter	DM54LS374			DM74LS374			Units
		Min	Nom	Max	Min	Nom	Max	
$V_{CC}$	Supply Voltage	4.5	5	5.5	4.75	5	5.25	V
$V_{IH}$	High Level Input Voltage	2			2			V
$V_{IL}$	Low Level Input Voltage			0.7			0.8	V
$I_{OH}$	High Level Output Current			-1			-2.6	mA
$I_{OL}$	Low Level Output Current			12			24	mA
$t_W$	Pulse Width (Note 4)	Clock High	15		15			ns
		Clock Low	15		15			
$t_{SU}$	Data Setup Time (Notes 1 & 4)	20 ↑			20 ↑			ns
$t_H$	Data Hold Time (Notes 1 & 4)	1 ↑			1 ↑			ns
$T_A$	Free Air Operating Temperature	-55		125	0		70	$^\circ C$

**Note 1:** The symbol (↑) indicates the rising edge of the clock pulse is used for reference.

**Note 4:**  $T_A = 25^\circ C$  and  $V_{CC} = 5V$ .

## 'LS374 Electrical Characteristics

over recommended operating free air temperature range (unless otherwise noted)

Symbol	Parameter	Conditions	Min	Typ (Note 1)	Max	Units
$V_I$	Input Clamp Voltage	$V_{CC} = \text{Min}, I_I = -18 \text{ mA}$			-1.5	V
$V_{OH}$	High Level Output Voltage	$V_{CC} = \text{Min}$ $I_{OH} = \text{Max}$ $V_{IL} = \text{Max}$ $V_{IH} = \text{Min}$	DM54	2.4	3.4	V
			DM74	2.4	3.1	
$V_{OL}$	Low Level Output Voltage	$V_{CC} = \text{Min}$ $I_{OL} = \text{Max}$ $V_{IL} = \text{Max}$ $V_{IH} = \text{Min}$	DM54		0.25	V
			DM74		0.35	
			$I_{OL} = 12 \text{ mA}$ $V_{CC} = \text{Min}$	DM74		0.25
$I_I$	Input Current @ Max Input Voltage	$V_{CC} = \text{Max}, V_I = 7V$			0.1	mA
$I_{IH}$	High Level Input Current	$V_{CC} = \text{Max}, V_I = 2.7V$			20	$\mu\text{A}$
$I_{IL}$	Low Level Input Current	$V_{CC} = \text{Max}, V_I = 0.4V$			-0.4	mA
$I_{OZH}$	Off-State Output Current with High Level Output Voltage Applied	$V_{CC} = \text{Max}, V_O = 2.7V$ $V_{IH} = \text{Min}, V_{IL} = \text{Max}$			20	$\mu\text{A}$
$I_{OZL}$	Off-State Output Current with Low Level Output Voltage Applied	$V_{CC} = \text{Max}, V_O = 0.4V$ $V_{IH} = \text{Min}, V_{IL} = \text{Max}$			-20	$\mu\text{A}$
$I_{OS}$	Short Circuit Output Current	$V_{CC} = \text{Max}$ (Note 2)	DM54	-50	-225	mA
			DM74	-50	-225	
$I_{CC}$	Supply Current	$V_{CC} = \text{Max}, D_n = \text{GND}, OC = 4.5V$		27	45	mA

## 'LS374 Switching Characteristics at $V_{CC} = 5V$ and $T_A = 25^\circ\text{C}$

(See Section 1 for Test Waveforms and Output Load)

Symbol	Parameter	$R_L = 667\Omega$				Units
		$C_L = 45 \text{ pF}$		$C_L = 150 \text{ pF}$		
		Min	Max	Min	Max	
$f_{MAX}$	Maximum Clock Frequency	35		20		MHz
$t_{PLH}$	Propagation Delay Time Low to High Level Output		28		32	ns
$t_{PHL}$	Propagation Delay Time High to Low Level Output		28		38	ns
$t_{PZH}$	Output Enable Time to High Level Output		28		44	ns
$t_{PZL}$	Output Enable Time to Low Level Output		28		44	ns
$t_{PHZ}$	Output Disable Time from High Level Output (Note 3)		20			ns
$t_{PLZ}$	Output Disable Time from Low Level Output (Note 3)		25			ns

**Note 1:** All typicals are at  $V_{CC} = 5V, T_A = 25^\circ\text{C}$ .

**Note 2:** Not more than one output should be shorted at a time, and the duration should not exceed one second.

**Note 3:**  $C_L = 5 \text{ pF}$ .

**Physical Dimensions** inches (millimeters)

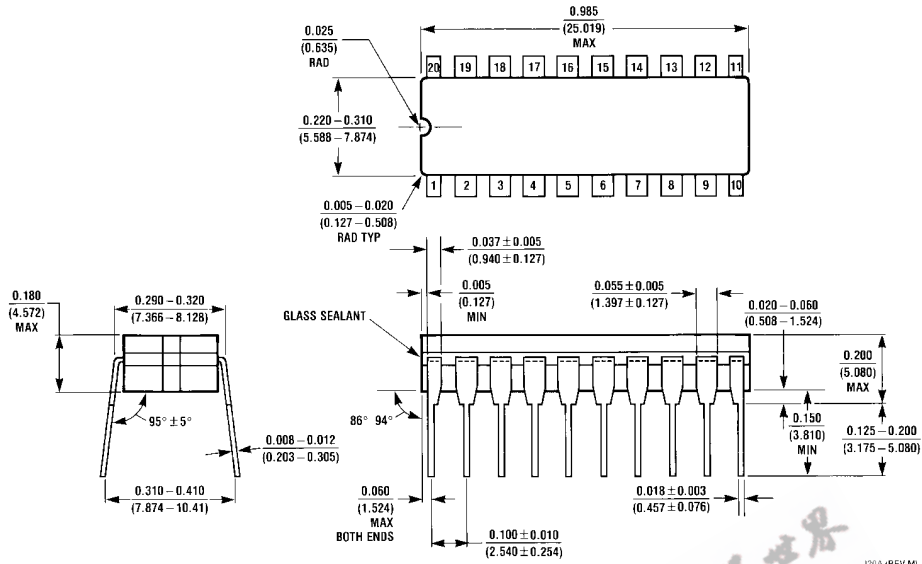

**20-Lead Ceramic Dual-In-Line Package (J)**  
**Order Number DM54LS373J or DM54LS374J**  
**NS Package Number J20A**

电子产品世界  
 EEPW.com.cn

**Physical Dimensions** inches (millimeters) (Continued)

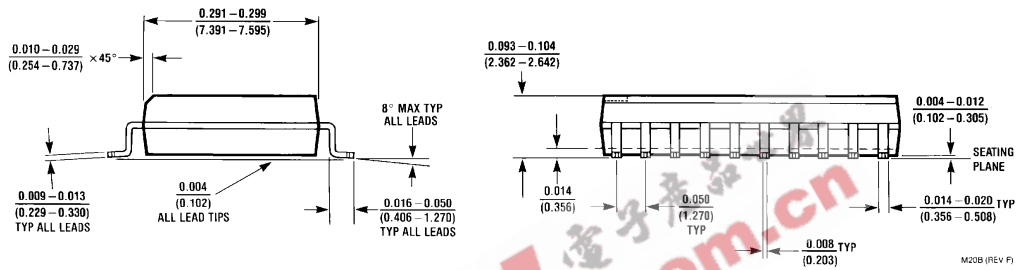
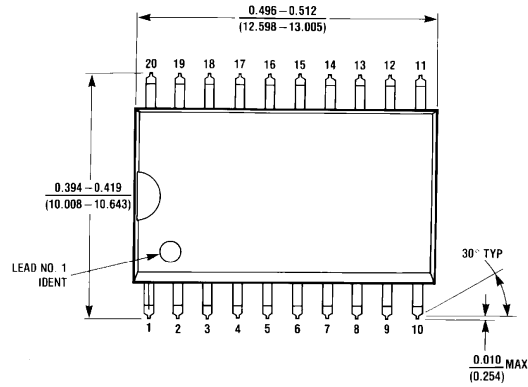

**20-Lead Wide Small Outline Molded Package (M)**  
**Order Number DM74LS373WM or DM74LS374WM**  
**NS Package Number M20B**

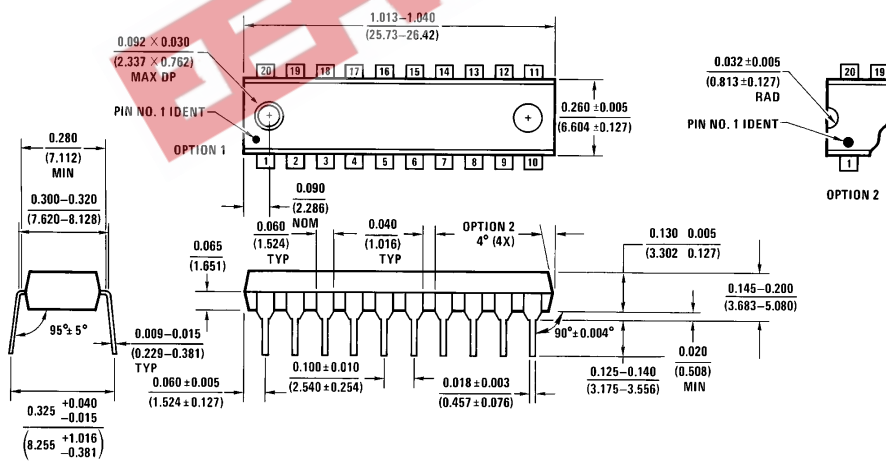

**20-Lead Molded Dual-In-Line Package (N)**  
**Order Number DM74LS373N and DM74LS374N**  
**NS Package Number N20A**

**DM54LS373/DM74LS373, DM54LS374/DM74LS374**  
**TRI-STATE Octal D-Type Transparent Latches and Edge-Triggered Flip-Flops**

**Physical Dimensions** inches (millimeters) (Continued)

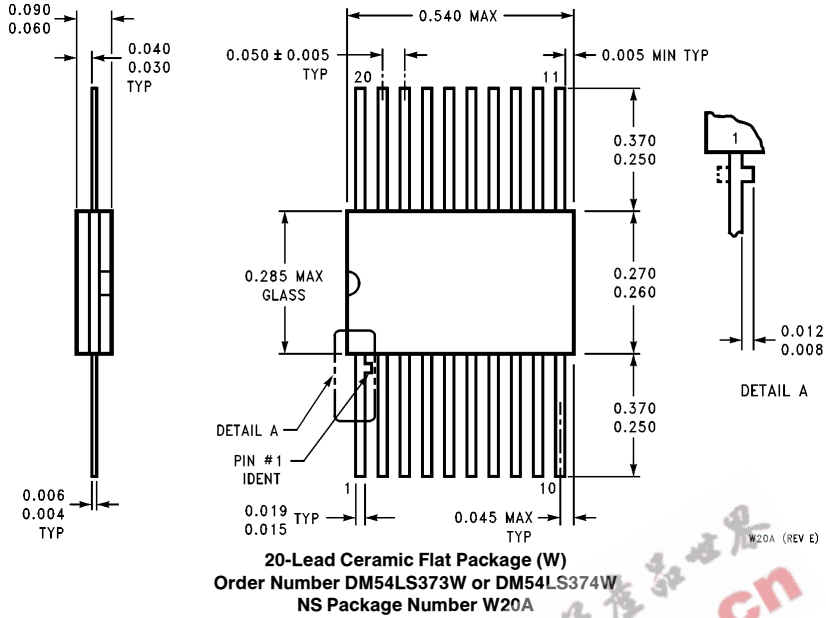

**LIFE SUPPORT POLICY**

NATIONAL'S PRODUCTS ARE NOT AUTHORIZED FOR USE AS CRITICAL COMPONENTS IN LIFE SUPPORT DEVICES OR SYSTEMS WITHOUT THE EXPRESS WRITTEN APPROVAL OF THE PRESIDENT OF NATIONAL SEMICONDUCTOR CORPORATION. As used herein:

1. Life support devices or systems are devices or systems which, (a) are intended for surgical implant into the body, or (b) support or sustain life, and whose failure to perform, when properly used in accordance with instructions for use provided in the labeling, can be reasonably expected to result in a significant injury to the user.
2. A critical component is any component of a life support device or system whose failure to perform can be reasonably expected to cause the failure of the life support device or system, or to affect its safety or effectiveness.



**National Semiconductor Corporation**  
 1111 West Bardin Road  
 Arlington, TX 76017  
 Tel: 1(800) 272-9959  
 Fax: 1(800) 737-7018

**National Semiconductor Europe**  
 Fax: (+49) 0-180-530 85 86  
 Email: cnjwge@levm2.nsc.com  
 Deutsch Tel: (+49) 0-180-530 85 85  
 English Tel: (+49) 0-180-532 78 32  
 Français Tel: (+49) 0-180-532 93 58  
 Italiano Tel: (+49) 0-180-534 16 80

**National Semiconductor Hong Kong Ltd.**  
 13th Floor, Straight Block,  
 Ocean Centre, 5 Canton Rd.  
 Tsimshatsui, Kowloon  
 Hong Kong  
 Tel: (852) 2737-1600  
 Fax: (852) 2736-9960

**National Semiconductor Japan Ltd.**  
 Tel: 81-043-299-2309  
 Fax: 81-043-299-2408