

## DM54LS377/DM74LS377 Octal D Flip-Flop with Common Enable and Clock

### General Description

The 'LS377 is an 8-bit register built using advanced low power Schottky technology. This register consists of eight D-type flip-flops with a buffered common clock and a buffered common input enable. The device is packaged in the space-saving (0.3 inch row spacing) 20-pin package.

### Features

- 8-bit high speed parallel registers
- Positive edge-triggered D-type flip-flops
- Fully buffered common clock and enable inputs

### Connection Diagram

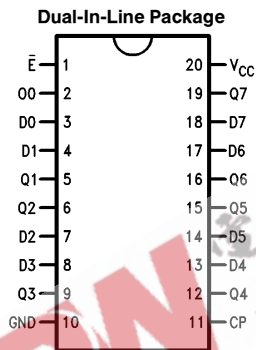

TL/F/9831-1

Order Number **DM54LS377E, DM54LS377J, DM54LS377W, DM74LS377WM or DM74LS377N**  
See NS Package Number  
**E20A, J20A, M20B, N20A or W20A**

Pin Names	Description
E	Enable Input (Active LOW)
D0-D7	Data Inputs
CP	Clock Pulse Input (Active Rising Edge)
Q0-Q7	Flip-Flop Outputs

## Absolute Maximum Ratings (Note)

If Military/Aerospace specified devices are required, please contact the National Semiconductor Sales Office/Distributors for availability and specifications.

Supply Voltage	7V
Input Voltage	7V
Operating Free Air Temperature Range	
DM54LS	-55°C to +125°C
DM74LS	0°C to +70°C
Storage Temperature Range	-65°C to +150°C

Note: The "Absolute Maximum Ratings" are those values beyond which the safety of the device cannot be guaranteed. The device should not be operated at these limits. The parametric values defined in the "Electrical Characteristics" table are not guaranteed at the absolute maximum ratings. The "Recommended Operating Conditions" table will define the conditions for actual device operation.

## Recommended Operating Conditions

Symbol	Parameter	DM54LS377			DM74LS377			Units
		Min	Nom	Max	Min	Nom	Max	
V <sub>CC</sub>	Supply Voltage	4.5	5	5.5	4.75	5	5.25	V
V <sub>IH</sub>	High Level Input Voltage	2			2			V
V <sub>IL</sub>	Low Level Input Voltage			0.7			0.8	V
I <sub>OH</sub>	High Level Output Current			-0.4			-0.4	mA
I <sub>OL</sub>	Low Level Output Current			4			8	mA
T <sub>A</sub>	Free Air Operating Temperature	-55		125	0		70	°C
t <sub>s</sub> (H)	Setup Time HIGH or LOW	20			10			ns
t <sub>s</sub> (L)	D <sub>n</sub> to CP	20			10			ns
t <sub>h</sub> (H)	Hold Time HIGH or LOW	5.0			5.0			ns
t <sub>h</sub> (L)	D <sub>n</sub> to CP	5.0			5.0			ns
t <sub>s</sub> (H)	Setup Time HIGH or LOW	10			10			ns
t <sub>s</sub> (L)	$\bar{E}$ to CP	20			20			ns
t <sub>h</sub> (H)	Hold Time HIGH or LOW	5.0			5.0			ns
t <sub>h</sub> (L)	$\bar{E}$ to CP	5.0			5.0			ns
t <sub>w</sub> (H)	CP Pulse Width HIGH or LOW	20			20			ns
t <sub>w</sub> (L)		20			20			ns

## Electrical Characteristics over recommended operating free air temperature range (unless otherwise noted)

Symbol	Parameter	Conditions	Min	Typ (Note 1)	Max	Units
V <sub>I</sub>	Input Clamp Voltage	V <sub>CC</sub> = Min, I <sub>I</sub> = -18 mA			-1.5	V
V <sub>OH</sub>	High Level Output Voltage	V <sub>CC</sub> = Min, I <sub>OH</sub> = Max V <sub>IL</sub> = Max	DM54 2.5			V
			DM74 2.7	3.4		
V <sub>OL</sub>	Low Level Output Voltage	V <sub>CC</sub> = Min, I <sub>OL</sub> = Max V <sub>IH</sub> = Min	DM54		0.4	V
		I <sub>OL</sub> = 4 mA, V <sub>CC</sub> = Min	DM74	0.35	0.5	
I <sub>I</sub>	Input Current @ Max Input Voltage	V <sub>CC</sub> = Max, V <sub>I</sub> = 7V V <sub>I</sub> = 10V	DM74		0.1	mA
			DM54			
I <sub>IH</sub>	High Level Input Current	V <sub>CC</sub> = Max, V <sub>I</sub> = 2.7V			20.0	μA
I <sub>IL</sub>	Low Level Input Current	V <sub>CC</sub> = Max, V <sub>I</sub> = 0.4V			-0.4	mA
I <sub>OS</sub>	Short Circuit Output Current	V <sub>CC</sub> = Max (Note 2)	DM54 -20		-100	mA
			DM74 -20		-100	
I <sub>CC</sub>	Supply Current	V <sub>CC</sub> = Max			28	mA

Note 1: All typicals are at V<sub>CC</sub> = 5V, T<sub>A</sub> = 25°C.

Note 2: Not more than one output should be shorted at a time, and the duration should not exceed one second.

### Switching Characteristics $V_{CC} = +5.0V, T_A = +25^\circ C$



Symbol	Parameter	$R_L = 2\text{ k}\Omega, C_L = 15\text{ pF}$		Units
		Min	Max	
$f_{max}$	Maximum Clock Frequency	30		MHz
$t_{PLH}$	Propagation Delay CP to $Q_n$		25	ns
$t_{PHL}$			25	

### Functional Description

The 'LS377 consists of eight edge-triggered D flip-flops with individual D inputs and Q outputs. The Clock (CP) and Enable input ( $\bar{E}$ ) are common to all flip-flops.

When  $\bar{E}$  is LOW, new data is entered into the register on the next LOW-to-HIGH transition of CP. When  $\bar{E}$  is HIGH, the register will retain the present data independent of the CP.

### Truth Table

Inputs			Output
$\bar{E}$	CP	$D_n$	$Q_n$
H	X	X	No Change
L		H	H
L		L	L

H = HIGH Voltage Level  
L = LOW Voltage Level  
X = Immaterial

### Logic Symbol

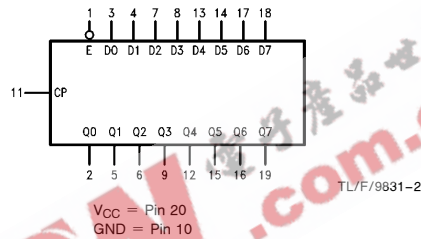

### Logic Diagram

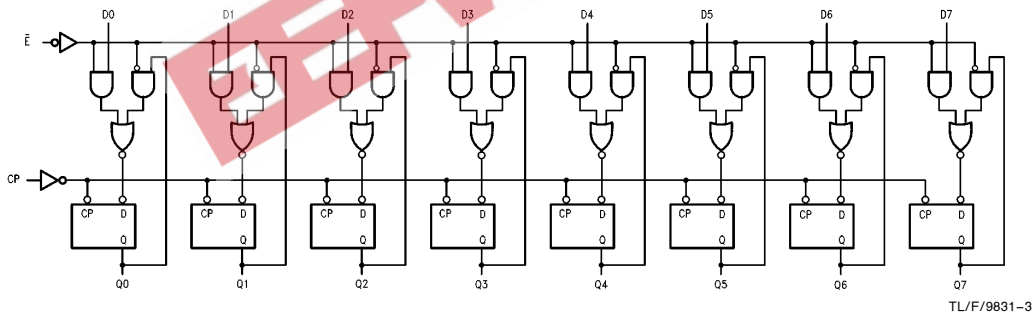

**Physical Dimensions** inches (millimeters)

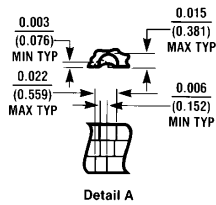
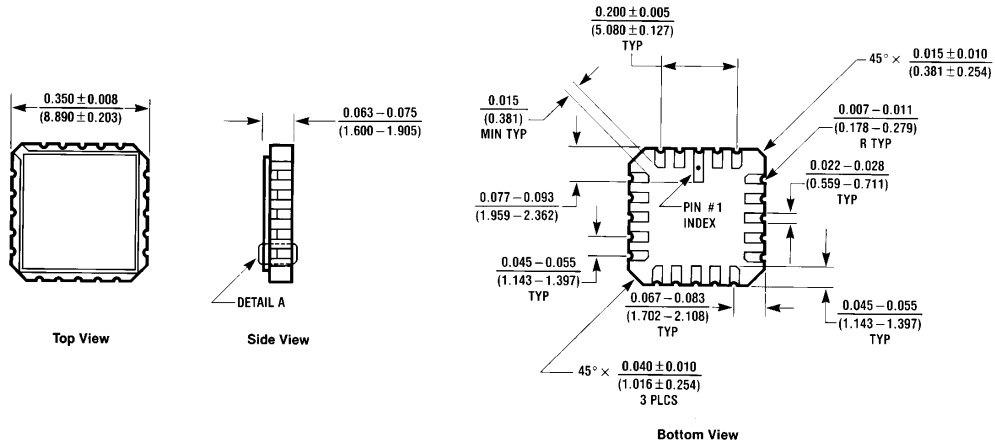

**Ceramic Leadless Chip Carrier (E)**  
**Order Number DM54LS377E**  
**NS Package Number E20A**

E20A (REV D)

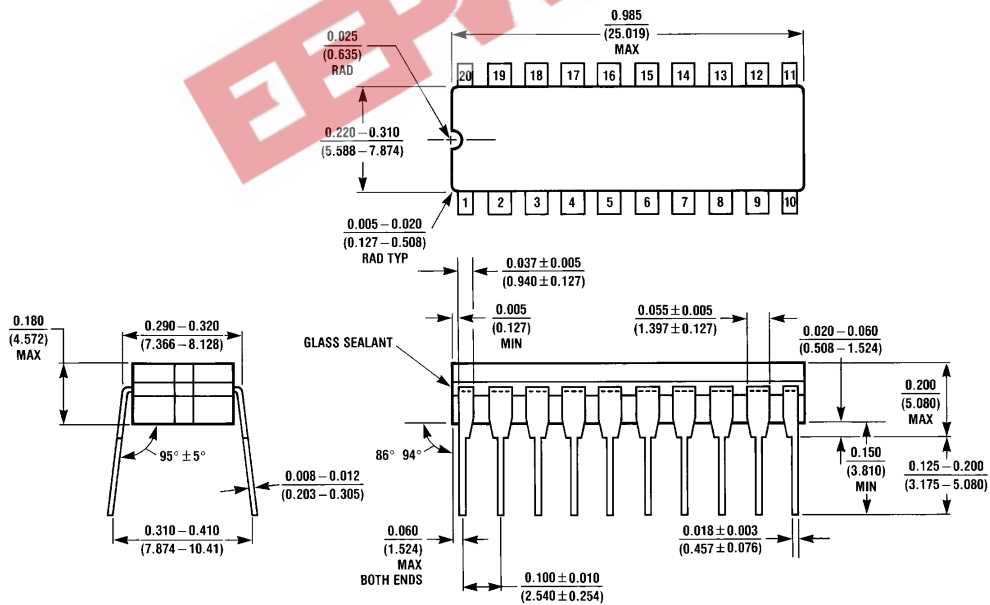

**20-Lead Ceramic Dual-In-Line Package (J)**  
**Order Number DM54LS377J**  
**NS Package Number J20A**

J20A (REV M)

**Physical Dimensions** inches (millimeters) (Continued)

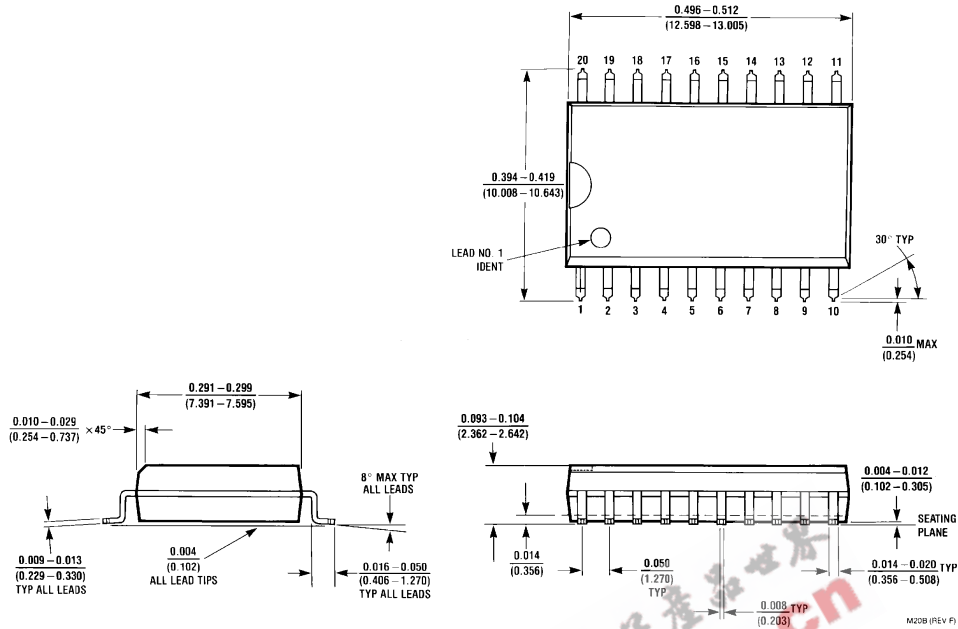

**20-Lead Wide Small Outline Molded Package (M)**  
**Order Number DM74LS377M**  
**NS Package Number M20B**

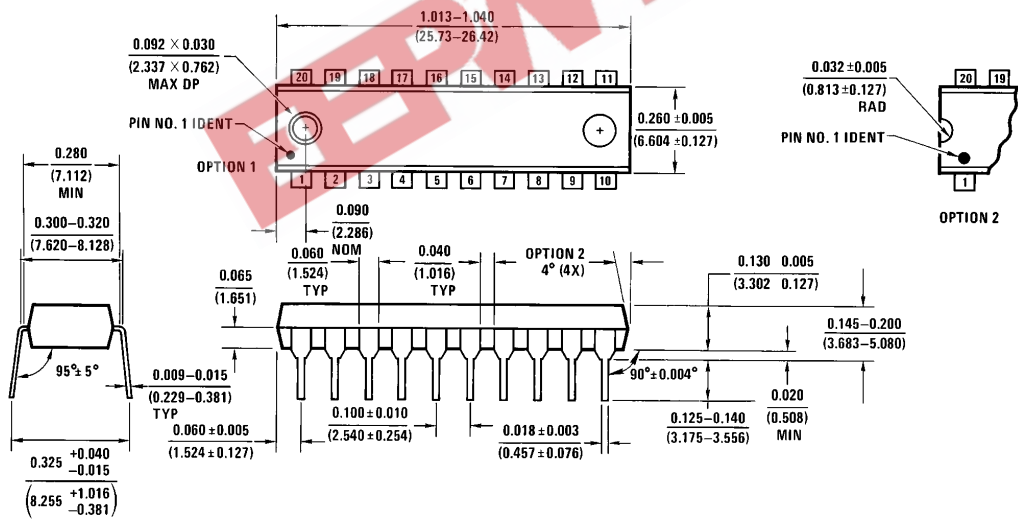

**20-Lead Molded Dual-In-Line Package (N)**  
**Order Number DM74LS377N**  
**NS Package Number N20A**

**Physical Dimensions** inches (millimeters) (Continued)

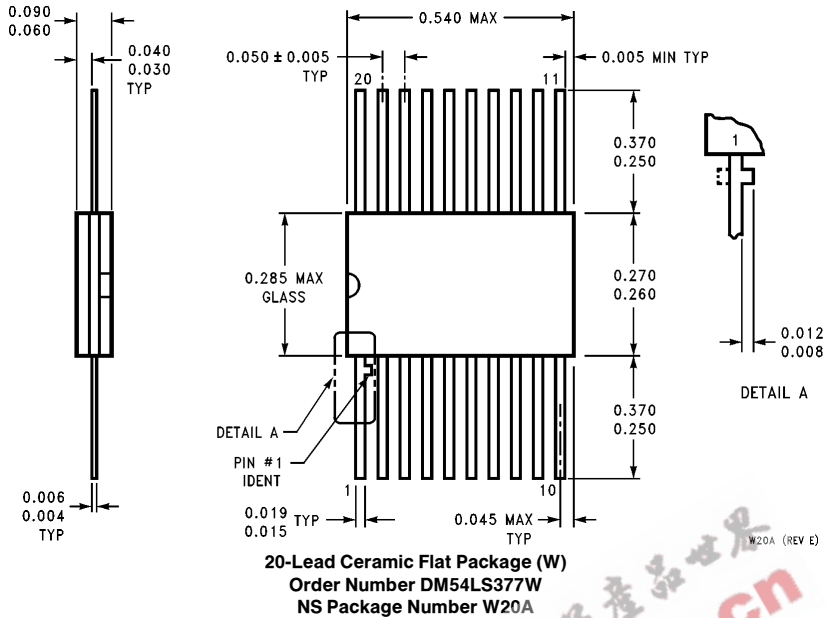

**LIFE SUPPORT POLICY**

NATIONAL'S PRODUCTS ARE NOT AUTHORIZED FOR USE AS CRITICAL COMPONENTS IN LIFE SUPPORT DEVICES OR SYSTEMS WITHOUT THE EXPRESS WRITTEN APPROVAL OF THE PRESIDENT OF NATIONAL SEMICONDUCTOR CORPORATION. As used herein:

1. Life support devices or systems are devices or systems which, (a) are intended for surgical implant into the body, or (b) support or sustain life, and whose failure to perform, when properly used in accordance with instructions for use provided in the labeling, can be reasonably expected to result in a significant injury to the user.
2. A critical component is any component of a life support device or system whose failure to perform can be reasonably expected to cause the failure of the life support device or system, or to affect its safety or effectiveness.



**National Semiconductor Corporation**  
 1111 West Bardin Road  
 Arlington, TX 76017  
 Tel: 1(800) 272-9959  
 Fax: 1(800) 737-7018

**National Semiconductor Europe**  
 Fax: (+49) 0-180-530 85 86  
 Email: cnjwge@levm2.nsc.com  
 Deutsch Tel: (+49) 0-180-530 85 85  
 English Tel: (+49) 0-180-532 78 32  
 Français Tel: (+49) 0-180-532 93 58  
 Italiano Tel: (+49) 0-180-534 16 80

**National Semiconductor Hong Kong Ltd.**  
 13th Floor, Straight Block,  
 Ocean Centre, 5 Canton Rd.  
 Tsimshatsui, Kowloon  
 Hong Kong  
 Tel: (852) 2737-1600  
 Fax: (852) 2736-9960

**National Semiconductor Japan Ltd.**  
 Tel: 81-043-299-2309  
 Fax: 81-043-299-2408