



DM74LS563 Octal D-Type Latch with TRI-STATE® Outputs

General Description

The 'LS563 is a high speed octal latch with buffered common Latch Enable (LE) and buffered common Output Enable (\overline{OE}) inputs.

This device is functionally identical to the 'LS573, but has inverted outputs.

Connection Diagram

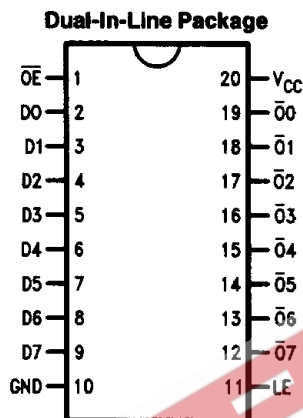

TL/F/10214-1

Order Number **DM74LS563WM** or **DM74LS563N**
See NS Package Number **M20B** or **N20A**

Logic Symbol

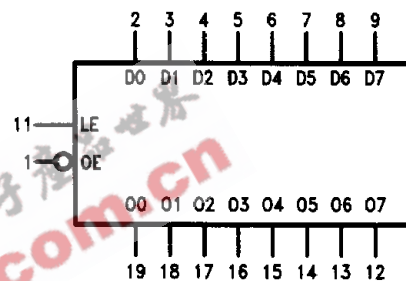

TL/F/10214-2

V_{CC} = Pin 20
GND = Pin 10

Pin Names	Description
D0-D7	Data Inputs
LE	Latch Enable Input (Active HIGH)
\overline{OE}	TRI-STATE Output Enable Input (Active LOW)
$\overline{O0}$ - $\overline{O7}$	TRI-STATE Latch Outputs

Absolute Maximum Ratings (Note)

If Military/Aerospace specified devices are required, please contact the National Semiconductor Sales Office/Distributors for availability and specifications.

Supply Voltage	7V
Input Voltage	7V
Operating Free Air Temperature Range	0°C to +70°C
DM74LS	
Storage Temperature Range	-65°C to +150°C

Note: The "Absolute Maximum Ratings" are those values beyond which the safety of the device cannot be guaranteed. The device should not be operated at these limits. The parametric values defined in the "Electrical Characteristics" table are not guaranteed at the absolute maximum ratings. The "Recommended Operating Conditions" table will define the conditions for actual device operation.

Recommended Operating Conditions

Symbol	Parameter	DM74LS563			Units
		Min	Nom	Max	
V _{CC}	Supply Voltage	4.75	5	5.25	V
V _{IH}	High Level Input Voltage	2			V
V _{IL}	Low Level Input Voltage			0.8	V
I _{OH}	High Level Output Current			-2.6	mA
I _{OL}	Low Level Output Current			24	mA
T _A	Free Air Operating Temperature	0		70	°C
t _s (H)	Setup Time HIGH or LOW	0			ns
t _s (L)	Dn to LE	0			ns
t _h (H)	Hold Time HIGH or LOW	10			ns
t _h (L)	Dn to LE	10			ns
t _w (H)	LE Pulse Width	15			ns
t _w (L)	HIGH or LOW	15			ns

Electrical Characteristics over recommended operating free air temperature range (unless otherwise noted)

Symbol	Parameter	Conditions	Min	Typ (Note 1)	Max	Units
V _I	Input Clamp Voltage	V _{CC} = Min, I _I = -18 mA			-1.5	V
V _{OH}	High Level Output Voltage	V _{CC} = Min, I _{OH} = Max, V _{IL} = Max, V _{IH} = Min	2.4	3.3		V
V _{OL}	Low Level Output Voltage	V _{CC} = Min, I _{OL} = Max, V _{IL} = Max, V _{IH} = Min		0.35	0.5	V
		I _{OL} = 12 mA, V _{CC} = Min		0.25	0.4	
I _I	Input Current @ Max Input Voltage	V _{CC} = Max, V _I = 7V			0.1	mA
I _{IH}	High Level Input Current	V _{CC} = Max, V _I = 2.7V			20	μA
I _{IL}	Low Level Input Current	V _{CC} = Max, V _I = 0.5V			-20	μA
I _{OZH}	Off-State Output Current with High Level Output Voltage Applied	V _{CC} = Max, V _O = 2.4V, V _{IH} = Min, V _{IL} = Max			20	μA
I _{OZL}	Off-State Output Current with Low Level Output Voltage Applied	V _{CC} = Max, V _O = 0.4V, V _{IH} = Min, V _{IL} = Max			-20	μA
I _{OS}	Short Circuit Output Current	V _{CC} = Max (Note 2)	-20		-100	mA
I _{CC}	Supply Current	V _{CC} = Max (Note 3)			40	mA

Note 1: All typicals are at V_{CC} = 5V, T_A = 25°C.

Note 2: Not more than one output should be shorted at a time, and the duration should not exceed one second.

Note 3: I_{CC} is measured with the DATA inputs grounded and the OUTPUT CONTROLS at 4.5V.

Switching Characteristics

$V_{CC} = +5.0V$, $T_A = +25^\circ C$ (See Section 1 for test waveforms and output loading)

Symbol	Parameter	$R_L = 2\text{ k}\Omega$ $C_L = 15\text{ pF}$		Units
		Min	Max	
t_{PLH} t_{PHL}	Propagation Delay Dn to On		23 25	ns
t_{PLH} t_{PHL}	Propagation Delay LE to On		35 35	ns
t_{PZH} t_{PZL}	Output Enable Time		28 36	ns
t_{PHZ} t_{PLZ}	Output Disable Time		20 25	ns

Functional Description

The 'LS563 contains eight D-type latches with TRI-STATE output buffers. When the Latch Enable (LE) input is HIGH, data on the Dn inputs enters the latches. In this condition the latches are transparent, i.e., a latch output will change state each time its D input changes. When LE is LOW the latches store the information that was present on the D in-

puts a setup time preceding the HIGH-to-LOW transition of LE. The TRI-STATE buffers are controlled by the Output Enable (\overline{OE}) input. When \overline{OE} is LOW, the buffers are in the bi-state mode. When \overline{OE} is HIGH the buffers are in the high impedance mode but this does not interfere with entering new data into the latches.

Logic Diagram

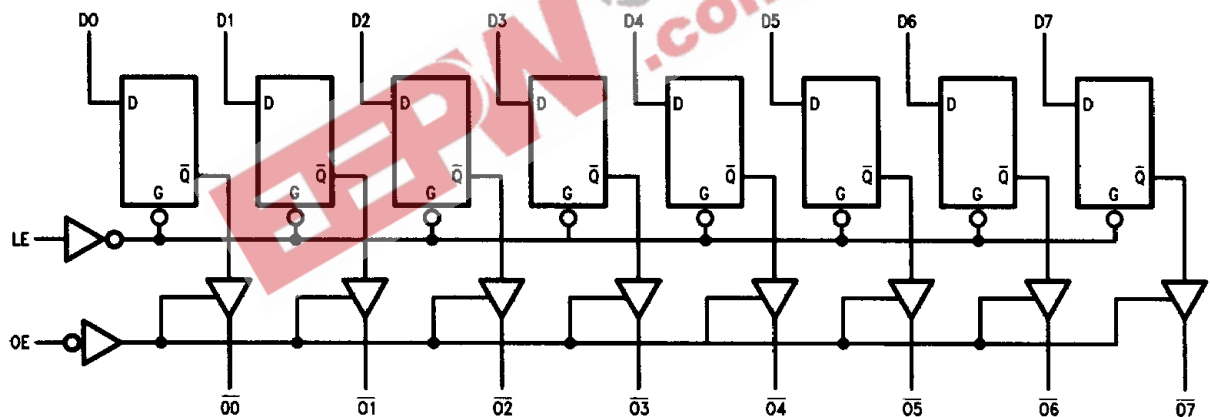

TL/F/10214-3