



PARALLEL D REGISTER WITH ENABLE

The MC54/74F378 is a 6-bit register with a buffered common enable. This device is similar to the F174 but with common Enable rather than common Master Reset.

The F378 consists of six edge-triggered D-type flip-flops with individual D inputs and Q outputs. The Clock (CP) and Enable (\bar{E}) inputs are common to all flip-flops.

When the \bar{E} input is LOW, new data is entered into the register on the LOW-to-HIGH transition of the CP input. When the \bar{E} input is HIGH the register will retain the present data independent of the CP input. This circuit is designed to prevent false clocking by transitions on the \bar{E} input.

- 6-Bit High-Speed Parallel Register
- Positive Edge-Triggered D-Type Inputs
- Fully Buffered Common Clock and Enable Inputs
- Input Clamp Diodes Limit High-Speed Termination Effects

CONNECTION DIAGRAM (TOP VIEW)

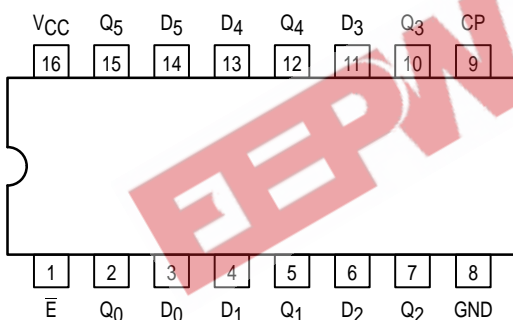

FUNCTION TABLE

Inputs			Output
\bar{E}	CP	D_n	Q_n
H		X	No Change
L		H	H
L		L	L

H = HIGH Voltage Level
 L = LOW Voltage Level
 X = Don't Care
 Z = High Impedance

MC54/74F378

PARALLEL D REGISTER WITH ENABLE

FAST™ SCHOTTKY TTL

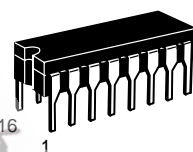

J SUFFIX
 CERAMIC
 CASE 620-09

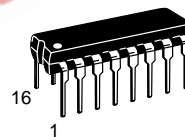

N SUFFIX
 PLASTIC
 CASE 648-08

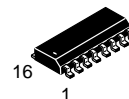

D SUFFIX
 SOIC
 CASE 751B-03

ORDERING INFORMATION

MC54FXXXJ Ceramic
 MC74FXXXN Plastic
 MC74FXXXD SOIC

LOGIC SYMBOL

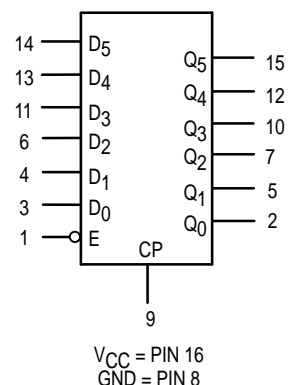

MC54/74F378

LOGIC DIAGRAM

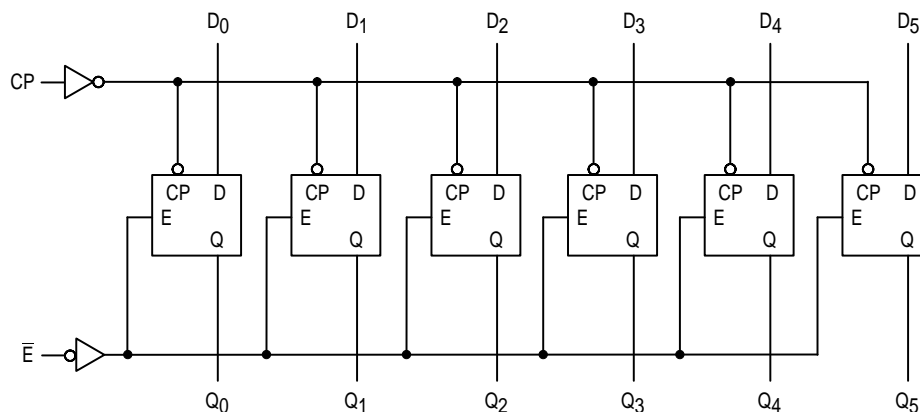

GUARANTEED OPERATING RANGES

Symbol	Parameter		Min	Typ	Max	Unit
V _{CC}	Supply Voltage	54, 74	4.5	5.0	5.5	V
T _A	Operating Ambient Temperature Range	54	-55	25	125	°C
		74	0	25	70	
I _{OH}	Output Current — HIGH	54, 74			-1.0	mA
I _{OL}	Output Current — LOW	54, 74			20	mA

DC CHARACTERISTICS OVER OPERATING TEMPERATURE RANGE (unless otherwise specified)

Symbol	Parameter	Limits			Unit	Test Conditions
		Min	Typ	Max		
V _{IH}	Input HIGH Voltage	2.0			V	Guaranteed Input HIGH Voltage
V _{IL}	Input LOW Voltage			0.8	V	Guaranteed Input LOW Voltage
V _{IK}	Input Clamp Diode Voltage			-1.2	V	V _{CC} = MIN, I _{IN} = -18 mA
V _{OH}	Output HIGH Voltage	54, 74	2.5		V	I _{OL} = -1.0 mA, V _{CC} = 4.50 V
		74	2.7		V	I _{OL} = -1.0 mA, V _{CC} = 4.75 V
V _{OL}	Output LOW Voltage			0.5	V	I _{OL} = 20 mA, V _{CC} = MIN
I _{IH}	Input HIGH Current			20	μA	V _{CC} = MAX, V _{IN} = 2.7 V
				0.1	mA	V _{CC} = MAX, V _{IN} = 7.0 V
I _{IL}	Input LOW Current			-0.6	mA	V _{CC} = MAX, V _{IN} = 0.5 V
I _{OS}	Output Short Circuit Current (Note 2)	-60		-150	mA	V _{CC} = MAX, V _{OUT} = 0 V
I _{CC}	Power Supply Current		30	45	mA	V _{CC} = MAX, V _{CP} = 0 V

NOTES:

- For conditions shown as MIN or MAX, use the appropriate value specified under recommended operating conditions for the applicable device type.
- Not more than one output should be shorted at a time, nor for more than 1 second.

MC54/74F378

AC CHARACTERISTICS

Symbol	Parameter	54/74F			54F		74F		Unit
		T _A = +25°C V _{CC} = 5.0 V C _L = 50 pF			T _A = -55°C to +125°C V _{CC} = 5.0 V ± 10% C _L = 50 pF		T _A = 0°C to +70°C V _{CC} = 5.0 V ± 10% C _L = 50 pF		
		Min	Typ	Max	Min	Max	Min	Max	
f _{max}	Maximum Input Frequency	80	140		80		80		MHz
t _{PLH}	Propagation Delay	3.0	5.5	7.5	3.0	9.5	3.0	8.5	ns
t _{PHL}	CP to Q _n	3.5	6.0	8.5	3.5	10.5	3.5	9.5	

AC OPERATING REQUIREMENTS

Symbol	Parameter	54/74F			54F		74F		Unit
		T _A = +25°C V _{CC} = 5.0 V			T _A = -55°C to +125°C V _{CC} = 5.0 V ± 10%		T _A = 0°C to +70°C V _{CC} = 5.0 V ± 10%		
		Min	Typ	Max	Min	max	Min	Max	
t _S (H)	Setup Time, HIGH or LOW	4.0			4.0		4.0		ns
t _S (L)	D _n to CP	4.0			4.0		4.0		
t _H (H)	Hold Time, HIGH or LOW	0			0		0		
t _H (L)	D _n to CP	0			0		0		ns
t _S (H)	Setup Time, HIGH or LOW	6.0			6.0		6.0		
t _S (L)	E to CP	6.0			6.0		6.0		
t _H (H)	Hold Time, HIGH or LOW	2.0			2.0		2.0		
t _H (L)	E to CP	2.0			2.0		2.0		ns
t _w (H)	CP Pulse Width, HIGH or LOW	4.0			4.0		4.0		
t _w (L)		6.0			6.0		6.0		