

Dual D Flip-Flop with Set and Reset

High-Performance Silicon-Gate CMOS

The MC54/74HC74A is identical in pinout to the LS74. The device inputs are compatible with standard CMOS outputs; with pullup resistors, they are compatible with LSTTL outputs.

This device consists of two D flip-flops with individual Set, Reset, and Clock inputs. Information at a D-input is transferred to the corresponding Q output on the next positive going edge of the clock input. Both Q and Q outputs are available from each flip-flop. The Set and Reset inputs are asynchronous.

- Output Drive Capability: 10 LSTTL Loads
- Outputs Directly Interface to CMOS, NMOS, and TTL
- Operating Voltage Range: 2.0 to 6.0 V
- Low Input Current: 1.0 μ A
- High Noise Immunity Characteristic of CMOS Devices
- In Compliance with the Requirements Defined by JEDEC Standard No. 7A
- Chip Complexity: 128 FETs or 32 Equivalent Gates

LOGIC DIAGRAM

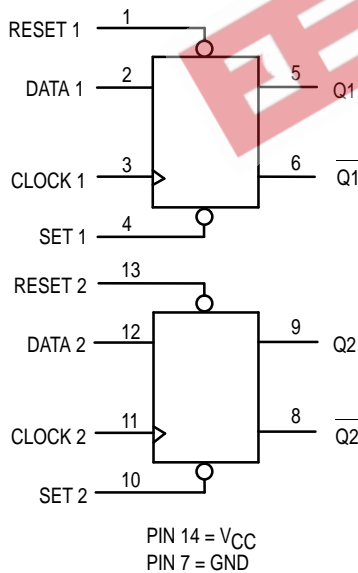

MC54/74HC74A

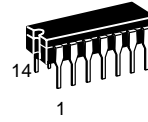

J SUFFIX
CERAMIC PACKAGE
CASE 632-08

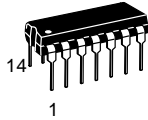

N SUFFIX
PLASTIC PACKAGE
CASE 646-06



D SUFFIX
SOIC PACKAGE
CASE 751A-03



DT SUFFIX
TSSOP PACKAGE
CASE 948G-01

ORDERING INFORMATION

| | |
|-------------|---------|
| MC54HCXXAJ | Ceramic |
| MC74HCXXAN | Plastic |
| MC74HCXXAD | SOIC |
| MC74HCXXADT | TSSOP |

PIN ASSIGNMENT

| | | | |
|---------|---|----|-----------------|
| RESET 1 | 1 | 14 | V _{CC} |
| DATA 1 | 2 | 13 | RESET 2 |
| CLOCK 1 | 3 | 12 | DATA 2 |
| SET 1 | 4 | 11 | CLOCK 2 |
| Q1 | 5 | 10 | SET 2 |
| Q1-bar | 6 | 9 | Q2 |
| GND | 7 | 8 | Q2-bar |

FUNCTION TABLE

| Inputs | | | | Outputs | |
|--------|-------|-------|------|-----------|-----------|
| Set | Reset | Clock | Data | Q | Q-bar |
| L | H | X | X | H | L |
| H | L | X | X | L | H |
| L | L | X | X | H* | H* |
| H | H | ↗ | H | H | L |
| H | H | ↘ | L | L | H |
| H | H | L | X | No Change | No Change |
| H | H | H | X | No Change | No Change |
| H | H | ~ | X | No Change | No Change |

* Both outputs will remain high as long as Set and Reset are low, but the output states are unpredictable if Set and Reset go high simultaneously.



MC54/74HC74A

MAXIMUM RATINGS*

| Symbol | Parameter | Value | Unit |
|------------------|--|--------------------------------|------|
| V _{CC} | DC Supply Voltage (Referenced to GND) | - 0.5 to + 7.0 | V |
| V _{in} | DC Input Voltage (Referenced to GND) | - 1.5 to V _{CC} + 1.5 | V |
| V _{out} | DC Output Voltage (Referenced to GND) | - 0.5 to V _{CC} + 0.5 | V |
| I _{in} | DC Input Current, per Pin | ± 20 | mA |
| I _{out} | DC Output Current, per Pin | ± 25 | mA |
| I _{CC} | DC Supply Current, V _{CC} and GND Pins | ± 50 | mA |
| P _D | Power Dissipation in Still Air, Plastic or Ceramic DIP† SOIC Package† TSSOP Package† | 750 500 450 | mW |
| T _{stg} | Storage Temperature | - 65 to + 150 | °C |
| T _L | Lead Temperature, 1 mm from Case for 10 Seconds (Plastic DIP, SOIC or TSSOP Package) (Ceramic DIP) | 260 300 | °C |

This device contains protection circuitry to guard against damage due to high static voltages or electric fields. However, precautions must be taken to avoid applications of any voltage higher than maximum rated voltages to this high-impedance circuit. For proper operation, V_{in} and V_{out} should be constrained to the range GND ≤ (V_{in} or V_{out}) ≤ V_{CC}. Unused inputs must always be tied to an appropriate logic voltage level (e.g., either GND or V_{CC}). Unused outputs must be left open.

* Maximum Ratings are those values beyond which damage to the device may occur.

Functional operation should be restricted to the Recommended Operating Conditions.

† Derating — Plastic DIP: - 10 mW/°C from 65° to 125°C

Ceramic DIP: - 10 mW/°C from 100° to 125°C

SOIC Package: - 7 mW/°C from 65° to 125°C

TSSOP Package: - 6.1 mW/°C from 65° to 125°C

For high frequency or heavy load considerations, see Chapter 2 of the Motorola High-Speed CMOS Data Book (DL129/D).

RECOMMENDED OPERATING CONDITIONS

| Symbol | Parameter | Min | Max | Unit |
|------------------------------------|--|---|-------------------------|------|
| V _{CC} | DC Supply Voltage (Referenced to GND) | 2.0 | 6.0 | V |
| V _{in} , V _{out} | DC Input Voltage, Output Voltage (Referenced to GND) | 0 | V _{CC} | V |
| T _A | Operating Temperature, All Package Types | - 55 | + 125 | °C |
| t _r , t _f | Input Rise and Fall Time (Figures 1, 2, 3) | V _{CC} = 2.0 V V _{CC} = 4.5 V V _{CC} = 6.0 V | 0 1000 500 400 | ns |

DC ELECTRICAL CHARACTERISTICS (Voltages Referenced to GND)

| Symbol | Parameter | Test Conditions | V _{CC} V | Guaranteed Limit | | | Unit |
|-----------------|-----------------------------------|---|---|------------------|--------|---------|------|
| | | | | - 55 to 25°C | ≤ 85°C | ≤ 125°C | |
| V _{IH} | Minimum High-Level Input Voltage | V _{out} = 0.1 V or V _{CC} - 0.1 V I _{out} ≤ 20 μA | 2.0 | 1.5 | 1.5 | 1.5 | V |
| | | | 4.5 | 3.15 | 3.15 | 3.15 | |
| | | | 6.0 | 4.2 | 4.2 | 4.2 | |
| V _{IL} | Maximum Low-Level Input Voltage | V _{out} = 0.1 V or V _{CC} - 0.1 V I _{out} ≤ 20 μA | 2.0 | 0.5 | 0.5 | 0.5 | V |
| | | | 4.5 | 1.35 | 1.35 | 1.35 | |
| | | | 6.0 | 1.8 | 1.8 | 1.8 | |
| V _{OH} | Minimum High-Level Output Voltage | V _{in} = V _{IH} or V _{IL} I _{out} ≤ 20 μA | 2.0 | 1.9 | 1.9 | 1.9 | V |
| | | | 4.5 | 4.4 | 4.4 | 4.4 | |
| | | | 6.0 | 5.9 | 5.9 | 5.9 | |
| | | | V _{in} = V _{IH} or V _{IL} I _{out} ≤ 4.0 mA I _{out} ≤ 5.2 mA | 4.5 | 3.98 | 3.84 | |
| V _{OL} | Maximum Low-Level Output Voltage | V _{in} = V _{IH} or V _{IL} I _{out} ≤ 20 μA | 2.0 | 0.1 | 0.1 | 0.1 | V |
| | | | 4.5 | 0.1 | 0.1 | 0.1 | |
| | | | 6.0 | 0.1 | 0.1 | 0.1 | |
| | | | V _{in} = V _{IH} or V _{IL} I _{out} ≤ 4.0 mA I _{out} ≤ 5.2 mA | 4.5 | 0.26 | 0.33 | |
| | | | 6.0 | 0.26 | 0.33 | 0.4 | |

DC ELECTRICAL CHARACTERISTICS (Voltages Referenced to GND) – continued

| Symbol | Parameter | Test Conditions | V _{CC} V | Guaranteed Limit | | | Unit |
|-----------------|--|---|----------------------|------------------|--------|---------|------|
| | | | | – 55 to 25°C | ≤ 85°C | ≤ 125°C | |
| I _{in} | Maximum Input Leakage Current | V _{in} = V _{CC} or GND | 6.0 | ± 0.1 | ± 1.0 | ± 1.0 | μA |
| I _{CC} | Maximum Quiescent Supply Current (per Package) | V _{in} = V _{CC} or GND I _{out} = 0 μA | 6.0 | 2.0 | 20 | 80 | μA |

NOTE: Information on typical parametric values can be found in Chapter 2 of the Motorola High-Speed CMOS Data Book (DL129/D).

AC ELECTRICAL CHARACTERISTICS (C_L = 50 pF, Input t_r = t_f = 6.0 ns)

| Symbol | Parameter | V _{CC} V | Guaranteed Limit | | | Unit |
|--|--|----------------------|------------------|-----------------|-----------------|------|
| | | | – 55 to 25°C | ≤ 85°C | ≤ 125°C | |
| f _{max} | Maximum Clock Frequency (50% Duty Cycle) (Figures 1 and 4) | 2.0 4.5 6.0 | 6.0 30 35 | 4.8 24 28 | 4.0 20 24 | MHz |
| t _{PLH} , t _{PHL} | Maximum Propagation Delay, Clock to Q or Q (Figures 1 and 4) | 2.0 4.5 6.0 | 100 20 17 | 125 25 21 | 150 30 26 | ns |
| t _{PLH} , t _{PHL} | Maximum Propagation Delay, Set or Reset to Q or Q (Figures 2 and 4) | 2.0 4.5 6.0 | 105 21 18 | 130 26 22 | 160 32 27 | ns |
| t _{TLH} , t _{THL} | Maximum Output Transition Time, Any Output (Figures 1 and 4) | 2.0 4.5 6.0 | 75 15 13 | 95 19 16 | 110 22 19 | ns |
| C _{in} | Maximum Input Capacitance | — | 10 | 10 | 10 | pF |

NOTE: For propagation delays with loads other than 50 pF, and information on typical parametric values, see Chapter 2 of the Motorola High-Speed CMOS Data Book (DL129/D).

| Symbol | Parameter | Typical @ 25°C, V _{CC} = 5.0 V | | Unit |
|-----------------|--|---|--|------|
| | | Value | | |
| C _{PD} | Power Dissipation Capacitance (Per Flip-Flop)* | 39 | | pF |

* Used to determine the no-load dynamic power consumption: P_D = C_{PD} V_{CC}²f + I_{CC} V_{CC}. For load considerations, see Chapter 2 of the Motorola High-Speed CMOS Data Book (DL129/D).

TIMING REQUIREMENTS (Input t_r = t_f = 6.0 ns)

| Symbol | Parameter | V _{CC} V | Guaranteed Limit | | | Unit |
|---------------------------------|---|----------------------|--------------------|--------------------|--------------------|------|
| | | | – 55 to 25°C | ≤ 85°C | ≤ 125°C | |
| t _{su} | Minimum Setup Time, Data to Clock (Figure 3) | 2.0 4.5 6.0 | 80 16 14 | 100 20 17 | 120 24 20 | ns |
| t _h | Minimum Hold Time, Clock to Data (Figure 3) | 2.0 4.5 6.0 | 3.0 3.0 3.0 | 3.0 3.0 3.0 | 3.0 3.0 3.0 | ns |
| t _{rec} | Minimum Recovery Time, Set or Reset Inactive to Clock (Figure 2) | 2.0 4.5 6.0 | 8.0 8.0 8.0 | 8.0 8.0 8.0 | 8.0 8.0 8.0 | ns |
| t _w | Minimum Pulse Width, Clock (Figure 1) | 2.0 4.5 6.0 | 60 12 10 | 75 15 13 | 90 18 15 | ns |
| t _w | Minimum Pulse Width, Set or Reset (Figure 2) | 2.0 4.5 6.0 | 60 12 10 | 75 15 13 | 90 18 15 | ns |
| t _r , t _f | Maximum Input Rise and Fall Times (Figures 1, 2, 3) | 2.0 4.5 6.0 | 1000 500 400 | 1000 500 400 | 1000 500 400 | ns |

SWITCHING WAVEFORMS

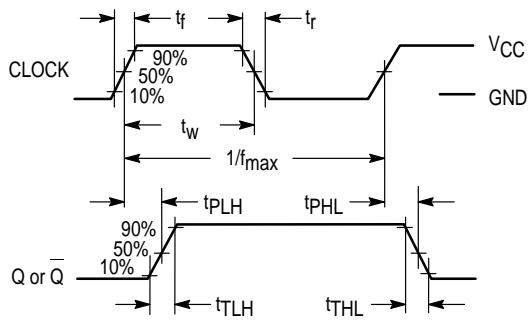

Figure 1.

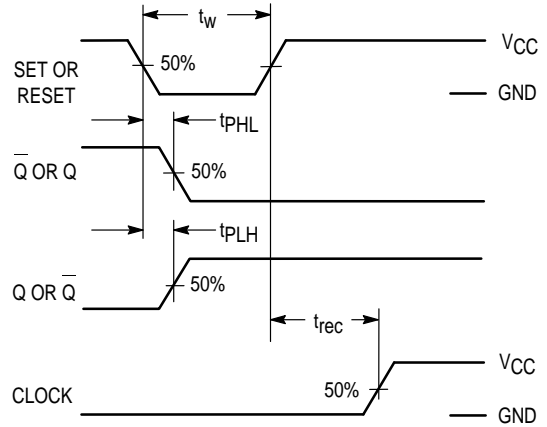

Figure 2.

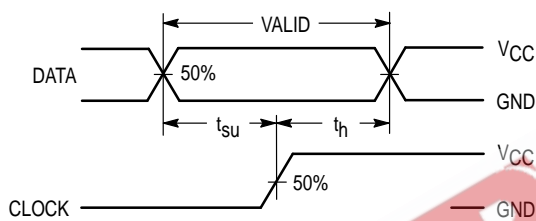
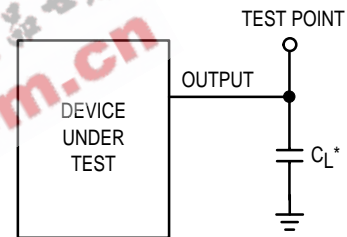

Figure 3.



* Includes all probe and jig capacitance

Figure 4.

EXPANDED LOGIC DIAGRAM

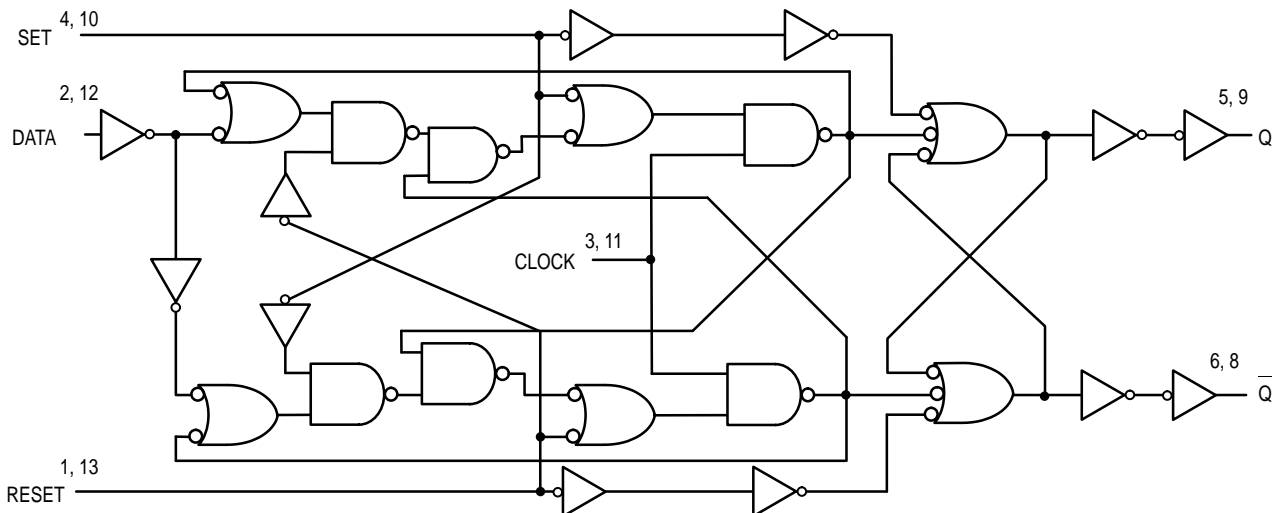

OUTLINE DIMENSIONS

J SUFFIX
 CERAMIC DIP PACKAGE
 CASE 632-08
 ISSUE Y

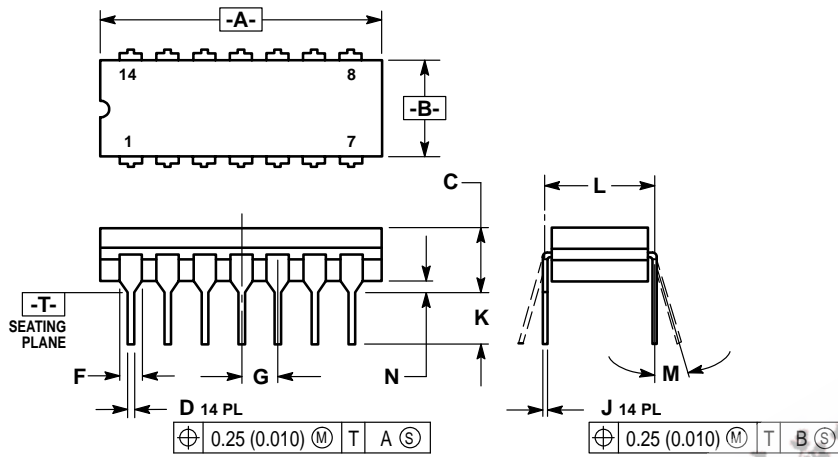

- NOTES:
1. DIMENSIONING AND TOLERANCING PER ANSI Y14.5M, 1982.
 2. CONTROLLING DIMENSION: INCH.
 3. DIMENSION L TO CENTER OF LEAD WHEN FORMED PARALLEL.
 4. DIMENSION F MAY NARROW TO 0.76 (0.030) WHERE THE LEAD ENTERS THE CERAMIC BODY.

| DIM | INCHES | | MILLIMETERS | |
|-----|-----------|-------|-------------|-------|
| | MIN | MAX | MIN | MAX |
| A | 0.750 | 0.785 | 19.05 | 19.94 |
| B | 0.245 | 0.280 | 6.23 | 7.11 |
| C | 0.155 | 0.200 | 3.94 | 5.08 |
| D | 0.015 | 0.020 | 0.39 | 0.50 |
| F | 0.055 | 0.065 | 1.40 | 1.65 |
| G | 0.100 BSC | | 2.54 BSC | |
| J | 0.008 | 0.015 | 0.21 | 0.38 |
| K | 0.125 | 0.170 | 3.18 | 4.31 |
| L | 0.300 BSC | | 7.62 BSC | |
| M | 0° | 15° | 0° | 15° |
| N | 0.020 | 0.040 | 0.51 | 1.01 |

N SUFFIX
 PLASTIC DIP PACKAGE
 CASE 646-06
 ISSUE L

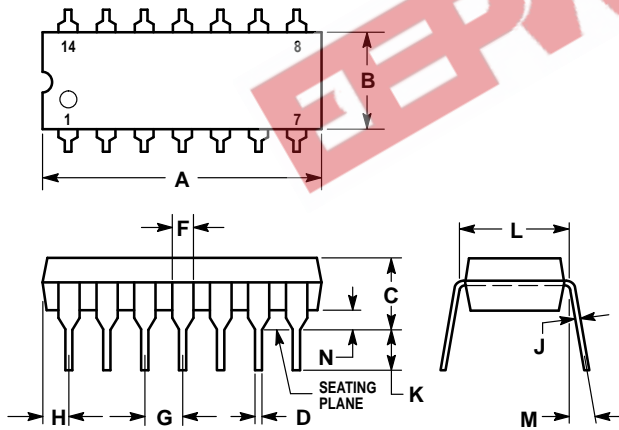

- NOTES:
1. LEADS WITHIN 0.13 (0.005) RADIUS OF TRUE POSITION AT SEATING PLANE AT MAXIMUM MATERIAL CONDITION.
 2. DIMENSION L TO CENTER OF LEADS WHEN FORMED PARALLEL.
 3. DIMENSION B DOES NOT INCLUDE MOLD FLASH.
 4. ROUNDED CORNERS OPTIONAL.

| DIM | INCHES | | MILLIMETERS | |
|-----|-----------|-------|-------------|-------|
| | MIN | MAX | MIN | MAX |
| A | 0.715 | 0.770 | 18.16 | 19.56 |
| B | 0.240 | 0.260 | 6.10 | 6.60 |
| C | 0.145 | 0.185 | 3.69 | 4.69 |
| D | 0.015 | 0.021 | 0.38 | 0.53 |
| F | 0.040 | 0.070 | 1.02 | 1.78 |
| G | 0.100 BSC | | 2.54 BSC | |
| H | 0.052 | 0.095 | 1.32 | 2.41 |
| J | 0.008 | 0.015 | 0.20 | 0.38 |
| K | 0.115 | 0.135 | 2.92 | 3.43 |
| L | 0.300 BSC | | 7.62 BSC | |
| M | 0° | 10° | 0° | 10° |
| N | 0.015 | 0.039 | 0.39 | 1.01 |

OUTLINE DIMENSIONS

D SUFFIX
 PLASTIC SOIC PACKAGE
 CASE 751A-03
 ISSUE F

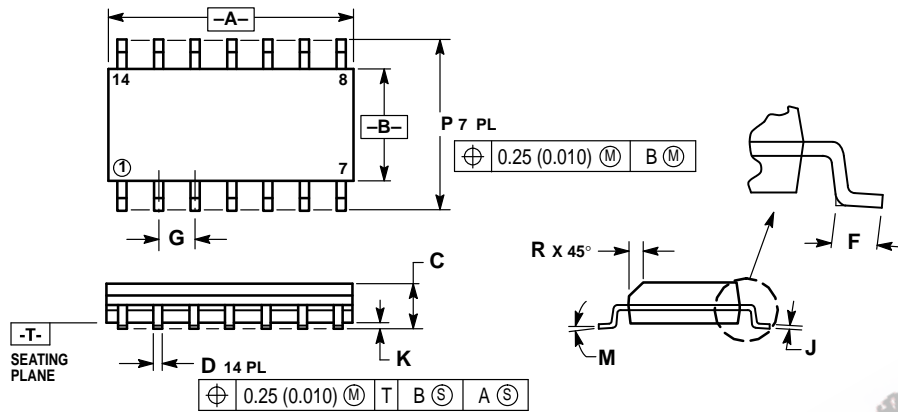

- NOTES:
1. DIMENSIONING AND TOLERANCING PER ANSI Y14.5M, 1982.
 2. CONTROLLING DIMENSION: MILLIMETER.
 3. DIMENSIONS A AND B DO NOT INCLUDE MOLD PROTRUSION.
 4. MAXIMUM MOLD PROTRUSION 0.15 (0.006) PER SIDE.
 5. DIMENSION D DOES NOT INCLUDE DAMBAR PROTRUSION. ALLOWABLE DAMBAR PROTRUSION SHALL BE 0.127 (0.005) TOTAL IN EXCESS OF THE D DIMENSION AT MAXIMUM MATERIAL CONDITION.

| DIM | MILLIMETERS | | INCHES | |
|-----|-------------|------|-----------|-------|
| | MIN | MAX | MIN | MAX |
| A | 8.55 | 8.75 | 0.337 | 0.344 |
| B | 3.80 | 4.00 | 0.150 | 0.157 |
| C | 1.35 | 1.75 | 0.054 | 0.068 |
| D | 0.35 | 0.49 | 0.014 | 0.019 |
| F | 0.40 | 1.25 | 0.016 | 0.049 |
| G | 1.27 BSC | | 0.050 BSC | |
| J | 0.19 | 0.25 | 0.008 | 0.009 |
| K | 0.10 | 0.25 | 0.004 | 0.009 |
| M | 0° | 7° | 0° | 7° |
| P | 5.80 | 6.20 | 0.228 | 0.244 |
| R | 0.25 | 0.50 | 0.010 | 0.019 |

DT SUFFIX
 PLASTIC TSSOP PACKAGE
 CASE 948G-01
 ISSUE O

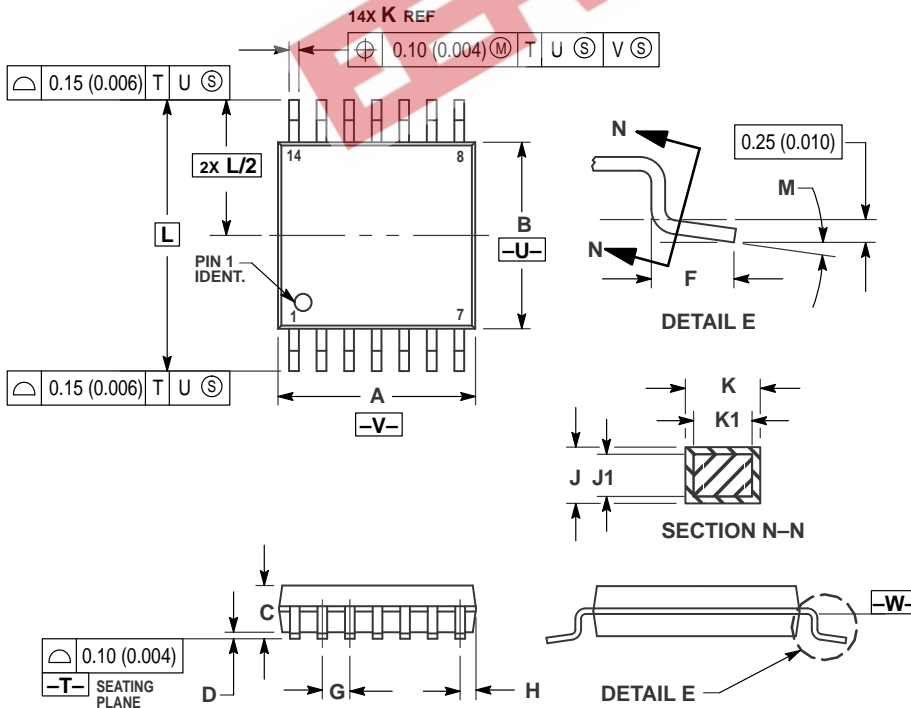

- NOTES:
1. DIMENSIONING AND TOLERANCING PER ANSI Y14.5M, 1982.
 2. CONTROLLING DIMENSION: MILLIMETER.
 3. DIMENSION A DOES NOT INCLUDE MOLD FLASH, PROTRUSIONS OR GATE BURRS. MOLD FLASH OR GATE BURRS SHALL NOT EXCEED 0.15 (0.006) PER SIDE.
 4. DIMENSION B DOES NOT INCLUDE INTERLEAD FLASH OR PROTRUSION. INTERLEAD FLASH OR PROTRUSION SHALL NOT EXCEED 0.25 (0.010) PER SIDE.
 5. DIMENSION K DOES NOT INCLUDE DAMBAR PROTRUSION. ALLOWABLE DAMBAR PROTRUSION SHALL BE 0.08 (0.003) TOTAL IN EXCESS OF THE K DIMENSION AT MAXIMUM MATERIAL CONDITION.
 6. TERMINAL NUMBERS ARE SHOWN FOR REFERENCE ONLY.
 7. DIMENSION A AND B ARE TO BE DETERMINED AT DATUM PLANE -W-.

| DIM | MILLIMETERS | | INCHES | |
|-----|-------------|------|-----------|-------|
| | MIN | MAX | MIN | MAX |
| A | 4.90 | 5.10 | 0.193 | 0.200 |
| B | 4.30 | 4.50 | 0.169 | 0.177 |
| C | — | 1.20 | — | 0.047 |
| D | 0.05 | 0.15 | 0.002 | 0.006 |
| F | 0.50 | 0.75 | 0.020 | 0.030 |
| G | 0.65 BSC | | 0.026 BSC | |
| H | 0.50 | 0.60 | 0.020 | 0.024 |
| J | 0.09 | 0.20 | 0.004 | 0.008 |
| J1 | 0.09 | 0.16 | 0.004 | 0.006 |
| K | 0.19 | 0.30 | 0.007 | 0.012 |
| K1 | 0.19 | 0.25 | 0.007 | 0.010 |
| L | 6.40 BSC | | 0.252 BSC | |
| M | 0° | 8° | 0° | 8° |

EEPW 电子产品世界
.com.cn

Motorola reserves the right to make changes without further notice to any products herein. Motorola makes no warranty, representation or guarantee regarding the suitability of its products for any particular purpose, nor does Motorola assume any liability arising out of the application or use of any product or circuit, and specifically disclaims any and all liability, including without limitation consequential or incidental damages. "Typical" parameters can and do vary in different applications. All operating parameters, including "Typicals" must be validated for each customer application by customer's technical experts. Motorola does not convey any license under its patent rights nor the rights of others. Motorola products are not designed, intended, or authorized for use as components in systems intended for surgical implant into the body, or other applications intended to support or sustain life, or for any other application in which the failure of the Motorola product could create a situation where personal injury or death may occur. Should Buyer purchase or use Motorola products for any such unintended or unauthorized application, Buyer shall indemnify and hold Motorola and its officers, employees, subsidiaries, affiliates, and distributors harmless against all claims, costs, damages, and expenses, and reasonable attorney fees arising out of, directly or indirectly, any claim of personal injury or death associated with such unintended or unauthorized use, even if such claim alleges that Motorola was negligent regarding the design or manufacture of the part. Motorola and  are registered trademarks of Motorola, Inc. Motorola, Inc. is an Equal Opportunity/Affirmative Action Employer.

How to reach us:

USA/EUROPE: Motorola Literature Distribution;
P.O. Box 20912; Phoenix, Arizona 85036. 1-800-441-2447

JAPAN: Nippon Motorola Ltd.; Tatsumi-SPD-JLDC, Toshikatsu Otsuki,
6F Seibu-Butsuryu-Center, 3-14-2 Tatsumi Koto-Ku, Tokyo 135, Japan. 03-3521-8315

MFAX: RMFAX0@email.sps.mot.com -TOUCHTONE (602) 244-6609
INTERNET: <http://Design-NET.com>

HONG KONG: Motorola Semiconductors H.K. Ltd.; 8B Tai Ping Industrial Park,
51 Ting Kok Road, Tai Po, N.T., Hong Kong. 852-26629298



◇ CODELINE

MC54/74HC74A/D

