



F100124 Hex TTL-to-ECL Translator

General Description

The F100124 is a hex translator, designed to convert TTL logic levels to 100K ECL logic levels. The inputs are compatible with standard or Schottky TTL. A common Enable input (E), when LOW, holds all inverting outputs HIGH and holds all true outputs LOW. The differential outputs allow each circuit to be used as an inverting/non-inverting translator or as a differential line driver. The output levels are voltage compensated.

When the circuit is used in the differential mode, the F100124, due to its high common mode rejection, overcomes voltage gradients between the TTL and ECL ground systems. The V_{EE} and V_{TTL} power may be applied in either order.

Refer to the F100324 datasheet for:

- PCC packaging
- Lower power
- Military versions
- Extended voltage specs (-4.2V to -5.7V)

Ordering Code: See Section 8

Logic Symbol

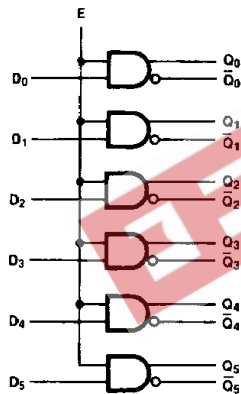

TL/F/9848-3

Pin Names	Description
D_0-D_5	Data Inputs
E	Enable Input
Q_0-Q_5	Data Outputs
$\bar{Q}_0-\bar{Q}_5$	Complementary Data Outputs

Connection Diagrams

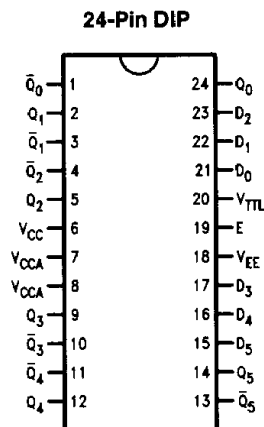

TL/F/9848-1

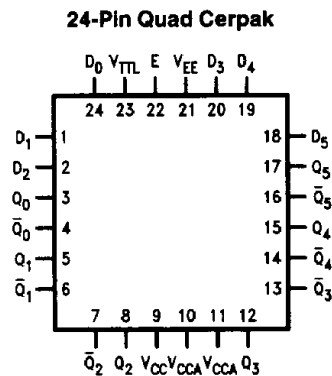

TL/F/9848-2

Absolute Maximum Ratings

Above which the useful life may be impaired. (Note 1)

If Military/Aerospace specified devices are required, please contact the National Semiconductor Sales Office/Distributors for availability and specifications.

Storage Temperature	-65°C to +150°C
Maximum Junction Temperature (T _J)	+150°C
Case Temperature under Bias (T _C)	0°C to +85°C

V _{EE} Pin Potential to Ground Pin	-7.0V to +0.5V
V _{TTL} Pin Potential to Ground Pin	+6.0V to -0.5V
Input Voltage (DC)	-0.5V to V _{TTL}
Output Current (DC Output HIGH)	-50 mA
Operating Range (V _{EE}) (Note 2)	-5.7V to -4.2V

DC Electrical Characteristics

V_{EE} = -4.5V, V_{CC} = V_{CCA} = GND, T_C = 0°C to +85°C (Note 3)

Symbol	Parameter	Min	Typ	Max	Units	Conditions (Note 4)	
V _{OH}	Output HIGH Voltage	-1025	-955	-880	mV	V _{IN} = V _{IH} (Max) or V _{IL} (Min)	Loading with 50Ω to -2.0V
V _{OL}	Output LOW Voltage	-1810	-1705	-1620			
V _{OHC}	Output HIGH Voltage	-1035			mV	V _{IN} = V _{IH} (Min) or V _{IL} (Max)	Loading with 50Ω to -2.0V
V _{OLC}	Output LOW Voltage			-1610			

DC Electrical Characteristics

V_{EE} = -4.2V, V_{CC} = V_{CCA} = GND, T_C = 0°C to +85°C (Note 3)

Symbol	Parameter	Min	Typ	Max	Units	Conditions (Note 4)	
V _{OH}	Output HIGH Voltage	-1020		-870	mV	V _{IN} = V _{IH} (Max) or V _{IL} (Min)	Loading with 50Ω to -2.0V
V _{OL}	Output LOW Voltage	-1810		-1605			
V _{OHC}	Output HIGH Voltage	-1030			mV	V _{IN} = V _{IH} (Min) or V _{IL} (Max)	Loading with 50Ω to -2.0V
V _{OLC}	Output LOW Voltage			-1595			

DC Electrical Characteristics

V_{EE} = -4.8V, V_{CC} = V_{CCA} = GND, T_C = 0°C to +85°C (Note 3)

Symbol	Parameter	Min	Typ	Max	Units	Conditions (Note 4)	
V _{OH}	Output HIGH Voltage	-1035		-880	mV	V _{IN} = V _{IH} (Max) or V _{IL} (Min)	Loading with 50Ω to -2.0V
V _{OL}	Output LOW Voltage	-1830		-1620			
V _{OHC}	Output HIGH Voltage	-1045			mV	V _{IN} = V _{IH} (Min) or V _{IL} (Max)	Loading with 50Ω to -2.0V
V _{OLC}	Output LOW Voltage			-1610			

Note 1: Absolute maximum ratings are those values beyond which the device may be damaged or have its useful life impaired. Functional operation under these conditions is not implied.

Note 2: Parametric values specified at -4.2V to -4.8V.

Note 3: The specified limits represent the "worst case" value for the parameter. Since these "worst case" values normally occur at the temperature extremes, additional noise immunity and guard banding can be achieved by decreasing the allowable system operating ranges.

Note 4: Conditions for testing shown in the tables are chosen to guarantee operation under "worst case" conditions.

DC Electrical Characteristics
 $V_{EE} = -4.2V$ to $-4.8V$ unless otherwise specified, $V_{CC} = V_{CCA} = GND$, $V_{TTL} = +4.5V$ to $+5.5V$, $T_C = 0^\circ C$ to $+85^\circ C$

Symbol	Parameter	Min	Typ	Max	Units	Conditions
V_{IH}	Input HIGH Voltage	2.0		5.0	V	Guaranteed HIGH Signal for All Inputs
V_{IL}	Input LOW Voltage	0		0.8	V	Guaranteed LOW Signal for All Inputs
V_{CD}	Input Clamp Diode Voltage	-1.5			V	$I_{IN} = -10$ mA
I_{IH}	Input HIGH Current Data Enable			20 120	μA	$V_{IN} = +2.4V$, All Other Inputs $V_{IN} = GND$
	Input HIGH Current Breakdown Test, All Inputs			1.0	mA	$V_{IN} = +5.5V$, All Other Inputs = GND
I_{IL}	Input LOW Current Data Enable	-1.6			mA	$V_{IN} = +0.4V$, All Other Inputs $V_{IN} = V_{IH}$
		-9.6				
I_{EE}	V_{EE} Power Supply Current	-140	-96	-52	mA	All Inputs $V_{IN} = +4.0V$
I_{TTL}	V_{TTL} Power Supply Current		44	75	mA	All Inputs $V_{IN} = GND$

Ceramic Dual-In-Line Package AC Electric Characteristics
 $V_{EE} = -4.2V$ to $-4.8V$, $V_{CC} = V_{CCA} = GND$, $V_{TTL} = +4.5V$ to $+5.5V$

Symbol	Parameter	$T_C = 0^\circ C$		$T_C = +25^\circ C$		$T_C = +85^\circ C$		Units	Conditions
		Min	Max	Min	Max	Min	Max		
t_{PLH} t_{PHL}	Propagation Delay Data and Enable to Output	0.50	3.00	0.50	2.90	0.50	3.00	ns	Figures 1 and 2
t_{TLH} t_{THL}	Transition Time 20% to 80%, 80% to 20%	0.45	1.80	0.45	1.80	0.45	1.80		

Cerpak AC Electrical Characteristics
 $V_{EE} = -4.2V$ to $-4.8V$, $V_{CC} = V_{CCA} = GND$, $V_{TTL} = +4.5V$ to $+5.5V$

Symbol	Parameter	$T_C = 0^\circ C$		$T_C = +25^\circ C$		$T_C = +85^\circ C$		Units	Conditions
		Min	Max	Min	Max	Min	Max		
t_{PLH} t_{PHL}	Propagation Delay Data and Enable to Output	0.50	2.80	0.50	2.70	0.50	2.80	ns	Figures 1 and 2
t_{TLH} t_{THL}	Transition Time 20% to 80%, 80% to 20%	0.45	1.70	0.45	1.70	0.45	1.70		

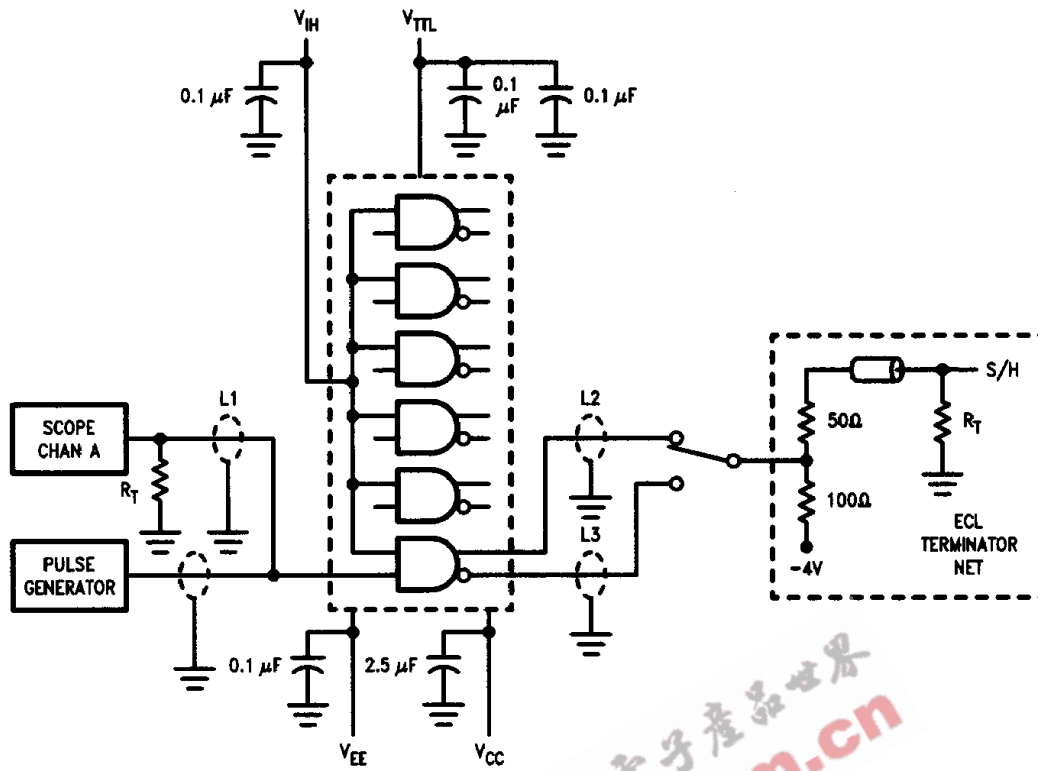

FIGURE 1. AC Test Circuit

TL/F/9848-5

Notes:

- V_{CC}, V_{CCA} = +0V, V_{EE} = -4.5V, V_{TTL} = +5.0V, V_{IH} = +3.0V
- L1, L2 and L3 = equal length 50Ω impedance lines
- R_T = 50Ω terminator internal to scope
- Decoupling 0.1 μF from GND to V_{CC}, V_{EE} and V_{TTL}
- All unused outputs are loaded with 50Ω to GND
- C_L = Fixture and stray capacitance ≤ 3 pF

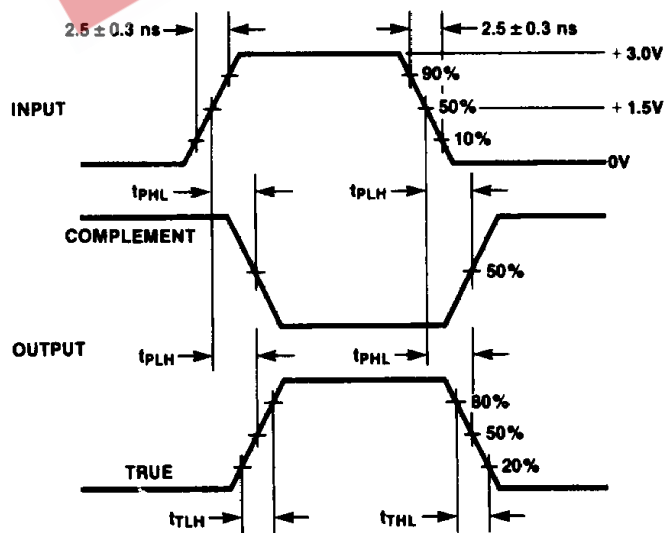

FIGURE 2. Propagation Delay and Transition Times

TL/F/9848-6