

FDP6030L / FDB6030L N-Channel Logic Level Enhancement Mode Field Effect Transistor

General Description

These N-Channel logic level enhancement mode power field effect transistors are produced using Fairchild's proprietary, high cell density, DMOS technology. This very high density process is especially tailored to minimize on-state resistance. These devices are particularly suited for low voltage applications such as DC/DC converters and high efficiency switching circuits where fast switching, low in-line power loss, and resistance to transients are needed.

Features

- 52 A, 30 V. $R_{DS(ON)} = 0.0135 \Omega @ V_{GS}=10 \text{ V}$
 $R_{DS(ON)} = 0.020 \Omega @ V_{GS}=4.5 \text{ V}$.
- Improved replacement for **NDP6030L/NDP6030L**.
- Low gate charge (typical 34 nC).
- Low Crss (typical 175 pF).
- Fast switching speed.

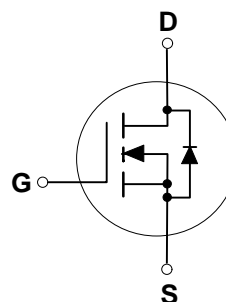
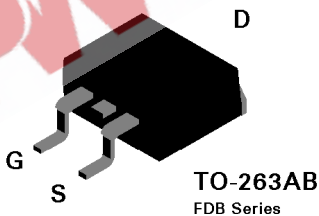
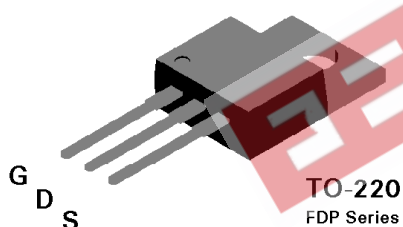

Absolute Maximum Ratings $T_C = 25^\circ\text{C}$ unless otherwise note

Symbol	Parameter	FDP6030L	FDB6030L	Units
V_{DSS}	Drain-Source Voltage		30	V
V_{GSS}	Gate-Source Voltage - Continuous		± 20	V
I_D	Drain Current - Continuous		52	A
	- Pulsed		156	
P_D	Maximum Power Dissipation @ $T_C = 25^\circ\text{C}$		75	W
	Derate above 25°C		0.5	
T_J, T_{STG}	Operating and Storage Temperature Range		-65 to 175	$^\circ\text{C}$

THERMAL CHARACTERISTICS

Symbol	Parameter	FDP6030L	FDB6030L	Units
$R_{\theta JC}$	Thermal Resistance, Junction-to-Case		2	$^\circ\text{C/W}$
$R_{\theta JA}$	Thermal Resistance, Junction-to-Ambient		62.5	$^\circ\text{C/W}$

Electrical Characteristics $T_c = 25^\circ\text{C}$ unless otherwise noted)						
Symbol	Parameter	Conditions	Min	Typ	Max	Unit
DRAIN-SOURCE AVALANCHE RATINGS (Note 1)						
W_{DSS}	Single Pulse Drain-Source Avalanche Energy	$V_{DD} = 15\text{ V}, I_D = 21\text{ A}$			150	mJ
I_{AR}	Maximum Drain-Source Avalanche Current				21	A
OFF CHARACTERISTICS						
BV_{DSS}	Drain-Source Breakdown Voltage	$V_{GS} = 0\text{ V}, I_D = 250\ \mu\text{A}$	30			V
$\Delta BV_{DSS}/\Delta T_J$	Breakdown Voltage Temp. Coefficient	$I_D = 250\ \mu\text{A}$, Referenced to 25°C		37		mV/ $^\circ\text{C}$
I_{DSS}	Zero Gate Voltage Drain Current	$V_{DS} = 24\text{ V}, V_{GS} = 0\text{ V}$			10	μA
I_{GSSF}	Gate - Body Leakage, Forward	$V_{GS} = 20\text{ V}, V_{DS} = 0\text{ V}$			100	nA
I_{GSSR}	Gate - Body Leakage, Reverse	$V_{GS} = -20\text{ V}, V_{DS} = 0\text{ V}$			-100	nA
ON CHARACTERISTICS (Note 1)						
$V_{GS(th)}$	Gate Threshold Voltage	$V_{DS} = V_{GS}, I_D = 250\ \mu\text{A}$	1	1.6	3	V
$\Delta V_{GS(th)}/\Delta T_J$	Gate Threshold Voltage Temp. Coefficient	$I_D = 250\ \mu\text{A}$, Referenced to 25°C		-4		mV/ $^\circ\text{C}$
$R_{DS(on)}$	Static Drain-Source On-Resistance	$V_{GS} = 10\text{ V}, I_D = 26\text{ A}$		0.0095	0.0135	Ω
		$T_J = 125^\circ\text{C}$		0.014	0.023	
		$V_{GS} = 4.5\text{ V}, I_D = 21\text{ A}$		0.015	0.02	
$I_{D(on)}$	On-State Drain Current	$V_{GS} = 10\text{ V}, V_{DS} = 10\text{ V}$	60			A
$I_{D(on)}$	On-State Drain Current	$V_{GS} = 4.5\text{ V}, V_{DS} = 10\text{ V}$	15			A
g_{FS}	Forward Transconductance	$V_{DS} = 10\text{ V}, I_D = 26\text{ A}$		37		S
DYNAMIC CHARACTERISTICS						
C_{iss}	Input Capacitance	$V_{DS} = 15\text{ V}, V_{GS} = 0\text{ V},$ $f = 1.0\text{ MHz}$		1230		pF
C_{oss}	Output Capacitance			640		pF
C_{rss}	Reverse Transfer Capacitance			175		pF
SWITCHING CHARACTERISTICS (Note 1)						
$t_{D(on)}$	Turn - On Delay Time	$V_{DD} = 15\text{ V}, I_D = 52\text{ A}$		7.6	15	nS
t_r	Turn - On Rise Time		$V_{GS} = 10\text{ V}, R_{GEN} = 24\ \Omega$		150	
$t_{D(off)}$	Turn - Off Delay Time			29	46	nS
t_f	Turn - Off Fall Time			17	27	nS
Q_g	Total Gate Charge	$V_{DS} = 12\text{ V}$ $I_D = 26\text{ A}, V_{GS} = 10\text{ V}$		34	46	nC
Q_{gs}	Gate-Source Charge			6		
Q_{gd}	Gate-Drain Charge			8		
DRAIN-SOURCE DIODE CHARACTERISTICS						
I_S	Maximum Continuous Drain-Source Diode Forward Current				52	A
V_{SD}	Drain-Source Diode Forward Voltage	$V_{GS} = 0\text{ V}, I_S = 26\text{ A}$ (Note 1)		0.91	1.3	V
		$T_J = 125^\circ\text{C}$		0.8	1.2	
Note 1. Pulse Test: Pulse Width $\leq 300\ \mu\text{s}$, Duty Cycle $\leq 2.0\%$.						

Typical Electrical Characteristics

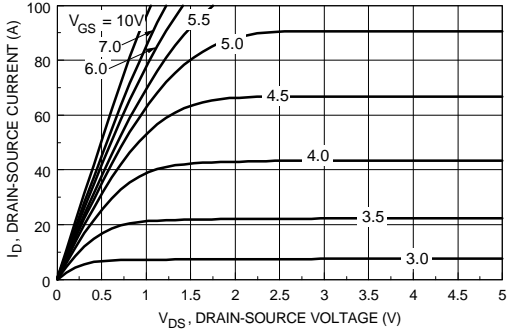

Figure 1. On-Region Characteristics.

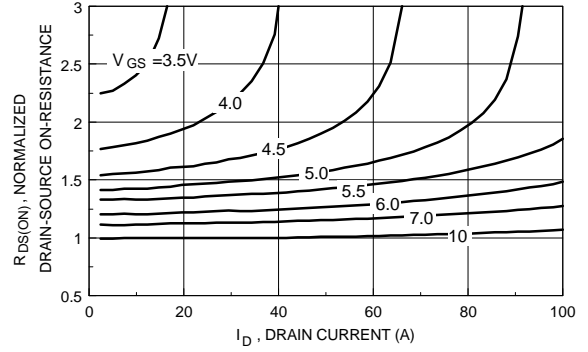

Figure 2. On-Resistance Variation with Drain Current and Gate Voltage.

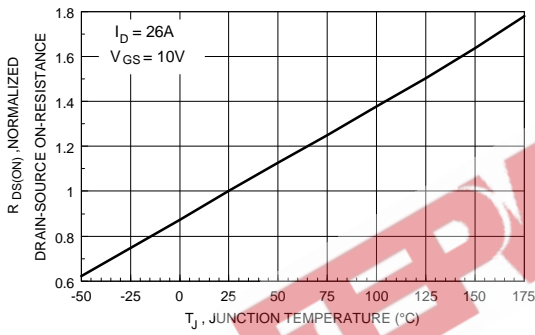

Figure 3. On-Resistance Variation with Temperature.

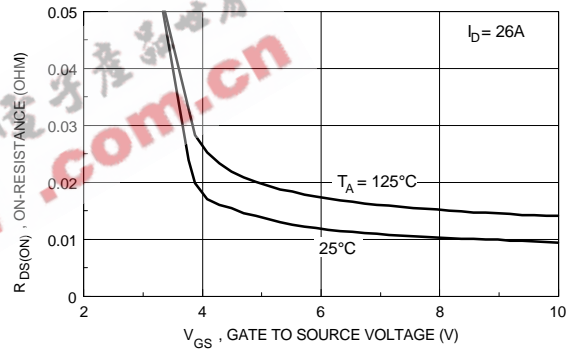

Figure 4. On-Resistance Variation with Gate-to-Source Voltage.

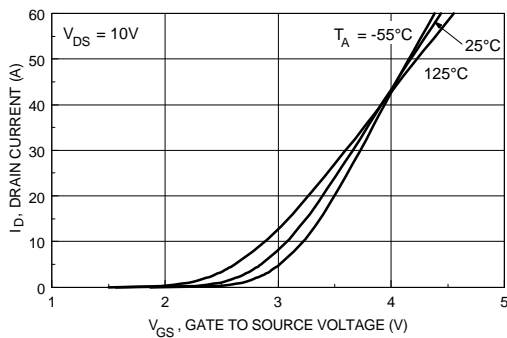

Figure 5. Transfer Characteristics.

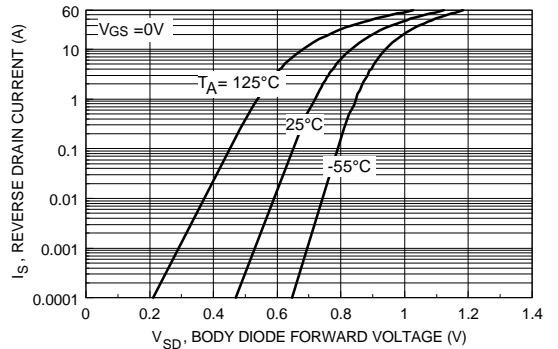

Figure 6. Body Diode Forward Voltage Variation with Source Current and Temperature.

Typical Electrical Characteristics (continued)

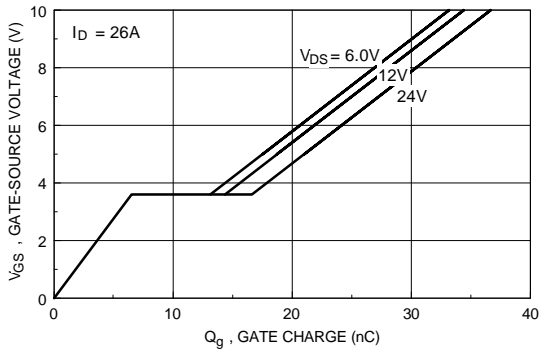

Figure 7. Gate Charge Characteristics.

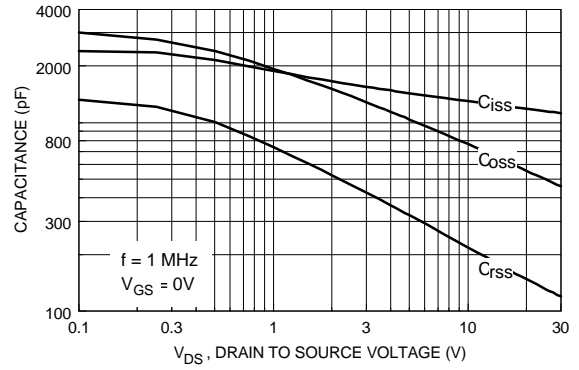

Figure 8. Capacitance Characteristics.

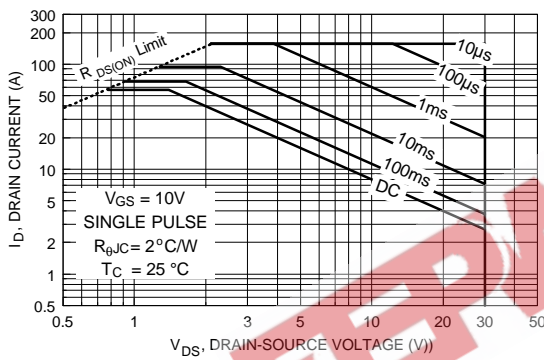

Figure 9. Maximum Safe Operating Area.

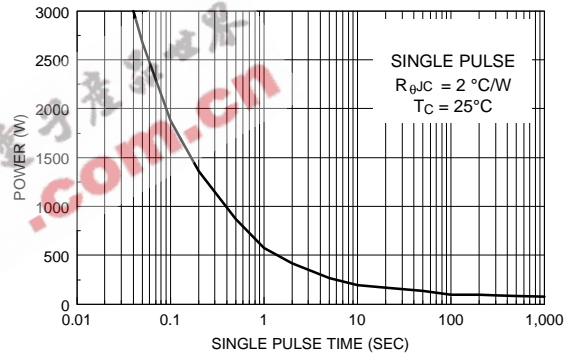

Figure 10. Single Pulse Maximum Power Dissipation.

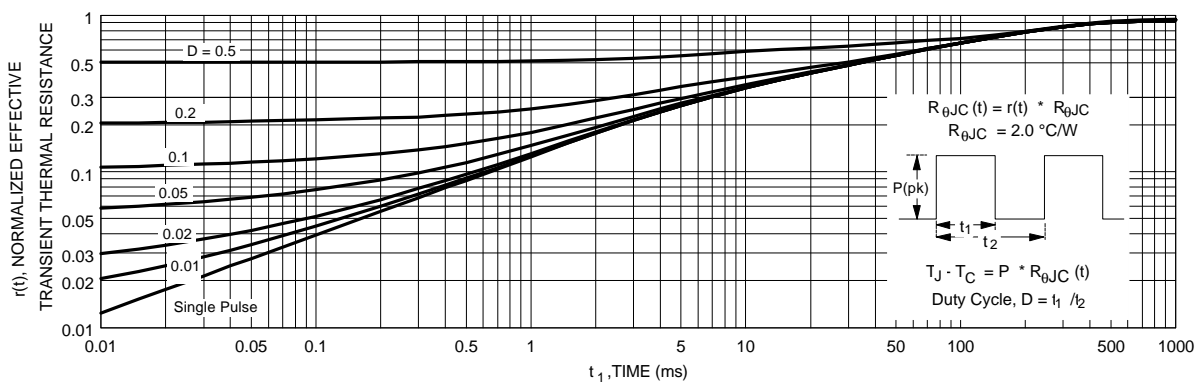

Figure 11. Transient Thermal Response Curve.