

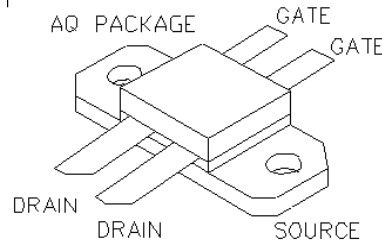

**General Description**

Silicon VDMOS and LDMOS transistors designed specifically for broadband RF applications. Suitable for Military Radios, Cellular and Paging Amplifier Base Stations, Broadcast FM/AM, MRI, Laser Driver and others.

"Polyfet"<sup>TM</sup> process features gold metal for greatly extended lifetime. Low output capacitance and high  $F_t$  enhance broadband performance



**PATENTED GOLD METALIZED SILICON GATE ENHANCEMENT MODE RF POWER VDMOS TRANSISTOR**

**5 Watts Push - Pull**

**Package Style AQ**

**HIGH EFFICIENCY, LINEAR, HIGH GAIN, LOW NOISE**

**ABSOLUTE MAXIMUM RATINGS (TC = 25 °C)**

Total Device Dissipation	Junction to Case Thermal Resistance	Maximum Junction Temperature	Storage Temperature	DC Drain Current	Drain to Gate Voltage	Drain to Source Voltage	Gate to Source Voltage
30 Watts	6 °C/W	200 °C	-65 °C to 150 °C	1.6 A	70 V	70V	30V

**RF CHARACTERISTICS ( 5WATTS OUTPUT )**

SYMBOL	PARAMETER	MIN	TYP	MAX	UNITS	TEST CONDITIONS
Gps	Common Source Power Gain	10			dB	Idq = 0.4 A, Vds = 28.0V, F = 1000 MHz
$\eta$	Drain Efficiency		45		%	Idq = 0.4 A, Vds = 28.0V, F = 1000 MHz
VSWR	Load Mismatch Toleranc			20:1	Relative	Idq = 0.4 A, Vds = 28.0V, F = 1000 MHz

**ELECTRICAL CHARACTERISTICS (EACH SIDE)**

SYMBOL	PARAMETER	MIN	TYP	MAX	UNITS	TEST CONDITIONS
Bvdss	Drain Breakdown Voltag	65			V	Ids = 0.01 A, Vgs = 0V
Idss	Zero Bias Drain Curren			0.2	mA	Vds = 28.0 V, Vgs = 0V
Igss	Gate Leakage Curren			1	uA	Vds = 0 V, Vgs = 30V
Vgs	Gate Bias for Drain Curren	1		7	V	Ids = 0.02 A, Vgs = Vds
gM	Forward Transconductanc		0.2		Mho	Vds = 10V, Vgs = 5V
Rdson	Saturation Resistanc		3.5		Ohm	Vgs = 20V, Ids = 1A
Idsat	Saturation Curren		1.2		Amp	Vgs = 20V, Vds = 10V
Ciss	Common Source Input Capacitanc		9		pF	Vds = 28.0 V, Vgs = 0V, F = 1 MHz
Crss	Common Source Feedback Capacitanc		1		pF	Vds = 28.0 V, Vgs = 0V, F = 1 MHz
Coss	Common Source Output Capacitanc		6		pF	Vds = 28.0 V, Vgs = 0V, F = 1 MHz

# F2003

POUT VS PIN GRAPH

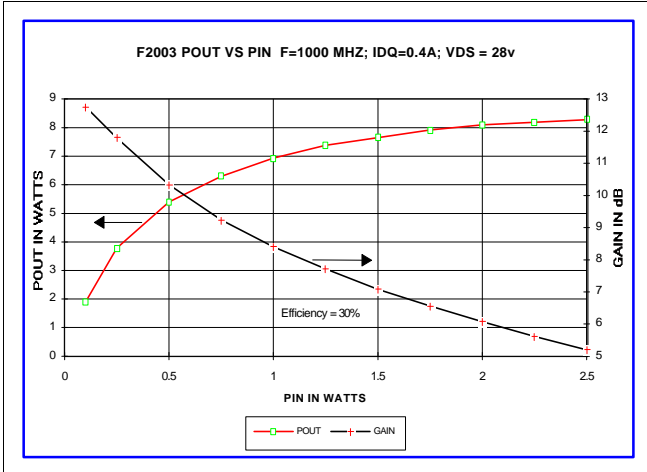

IV CURVE

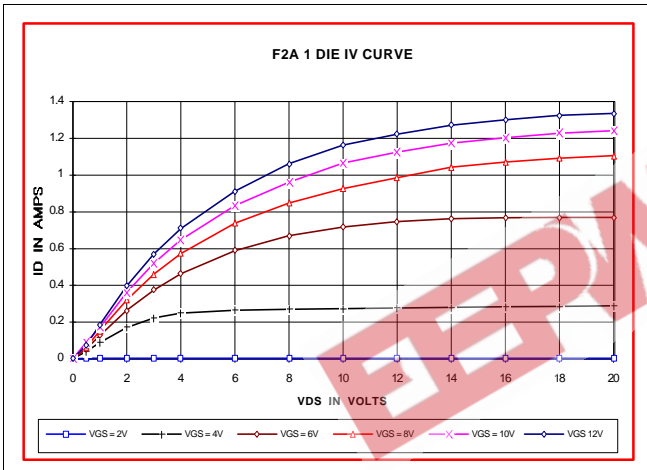

S11 AND S22 SMITH CHART

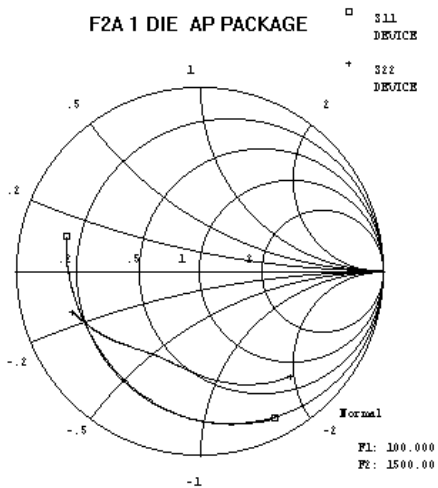

CAPACITANCE VS VOLTAGE

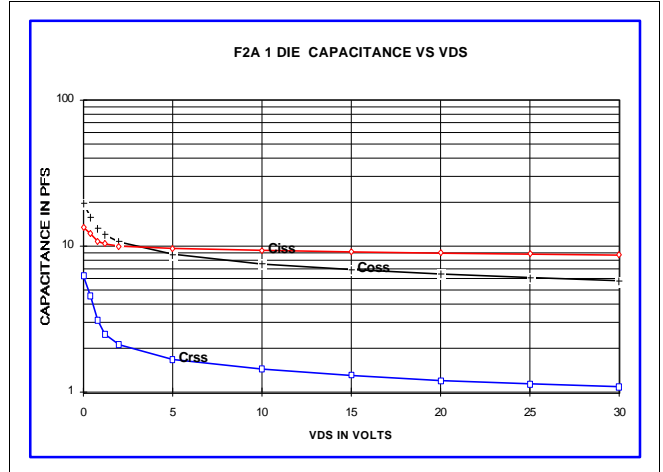

ID AND GM VS VGS

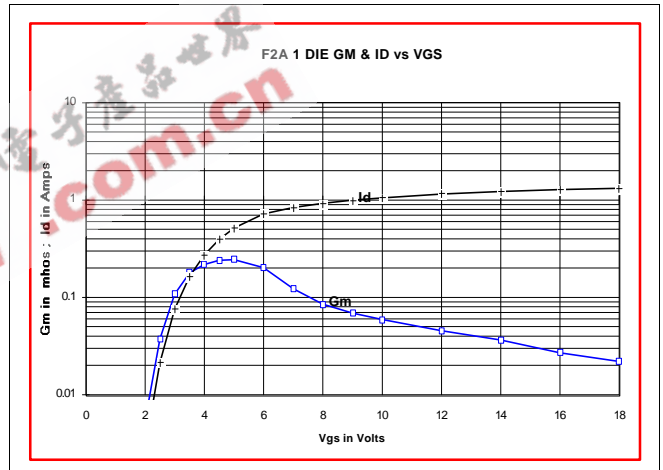

PACKAGE DIMENSIONS IN INCHES

