

# FOR BOARD-TO-BOARD CONNECTION

## 228 SERIES (CARD EDGE TYPE)

### ■ FEATURES

- 1.27 mm (0.050 in.) pitch contact arrangement in two rows enables high-density mounting.
- Standard types with 30 to 120 contacts, S types with 112, 132, and 182 contacts, SMT types with 26, 40, 50, 60, and 100 contacts are available for various purposes.
- Double side separated connection for 1.6 mm (0.063 in.) PC board
- Tails are spaced in a four-row staggered arrangement (2.54 mm × 1.905 mm) (0.100 in. × 0.075 in.) for easy PC board design.
- Insulation is UL-approved (94V-0) and is washable.



### ■ SPECIFICATIONS

Item	Specifications	
Operating temperature range	-55°C to +105°C	
Current rating	DC 2 A	
Voltage rating	AC 250 V	
Contact resistance	35 mΩ max. (DC 6 V, 0.1 A)	
Insulation resistance	1000 MΩ min. (DC 500 V)	
Dielectric withstand voltage	AC 500 V for 1 minute	
Insertion force	Standard type	2 kg max. (10 pins)
	SMT type	1 kg max. (10 pins)
Withdrawal force	Standard type	250 g min. (10 pins)
	SMT type	50 g min. (10 pins)
Applicable PC board (standard)	Mounting through hole: 0.8 to 1.6 mm (0.031 to 0.063 in.)	
	Mating card edge: 1.6 mm (0.063 in.)	

### ■ MATERIALS

Item	Materials	
Insulator	Polyester (UL94V-0)	
Conductor	Copper alloy	
Plating	Contact	Gold plating
	Terminal	Palladium plating

# 228 Series (Card Edge Type)

## ORDERING CODE

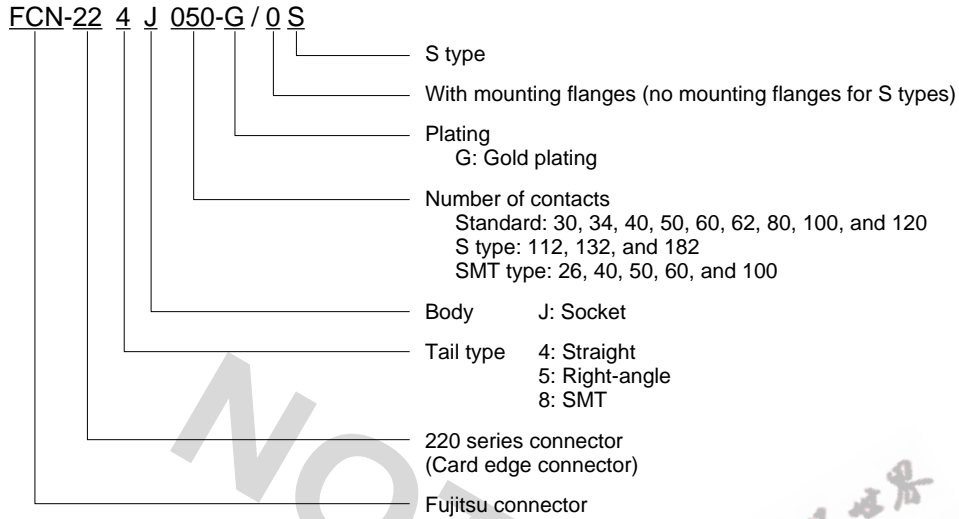

## APPLICATIONS

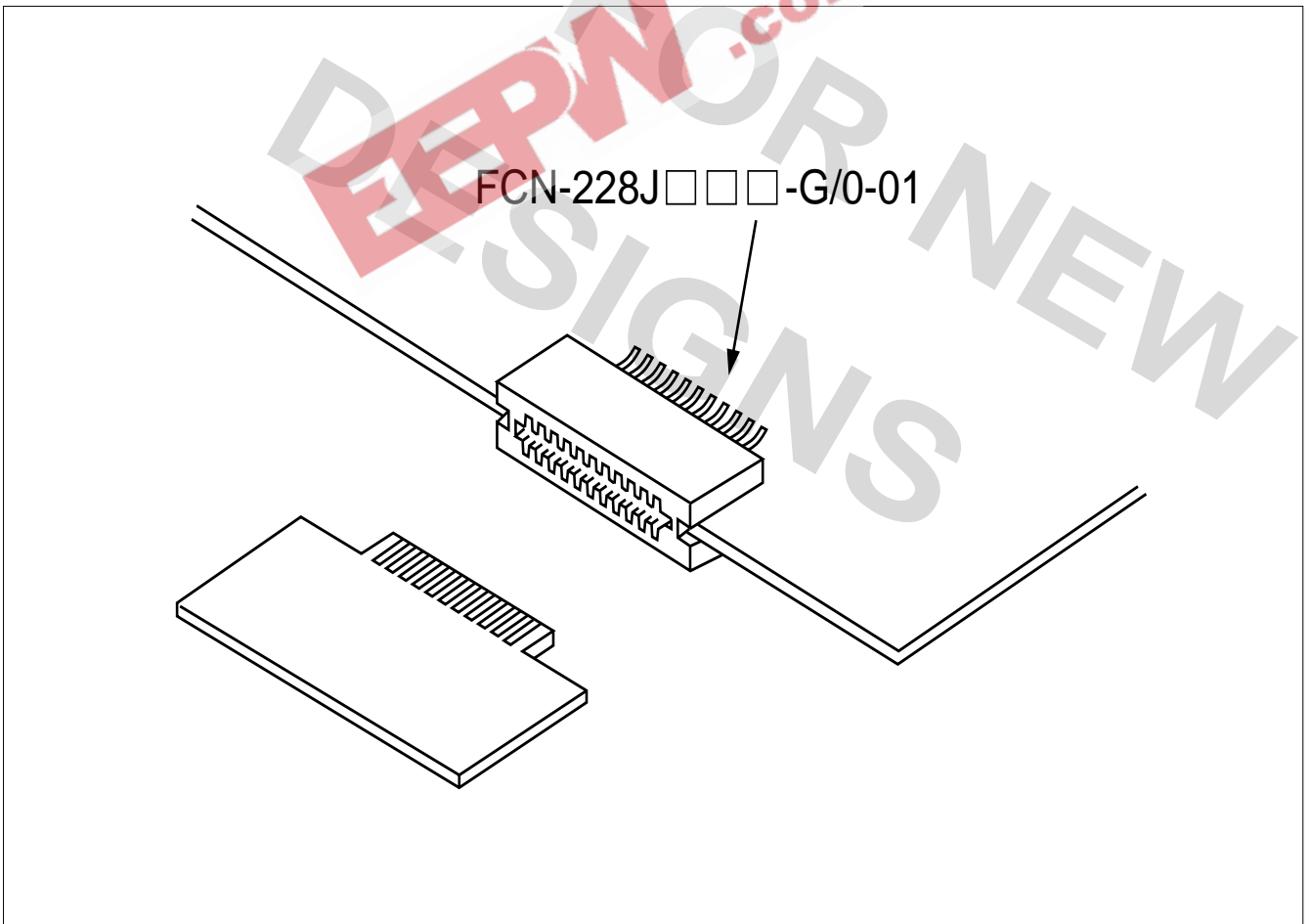

# 228 Series (Card Edge Type)

## SMT TYPE (STRADDLE MOUNT)

### ■ DIMENSIONS

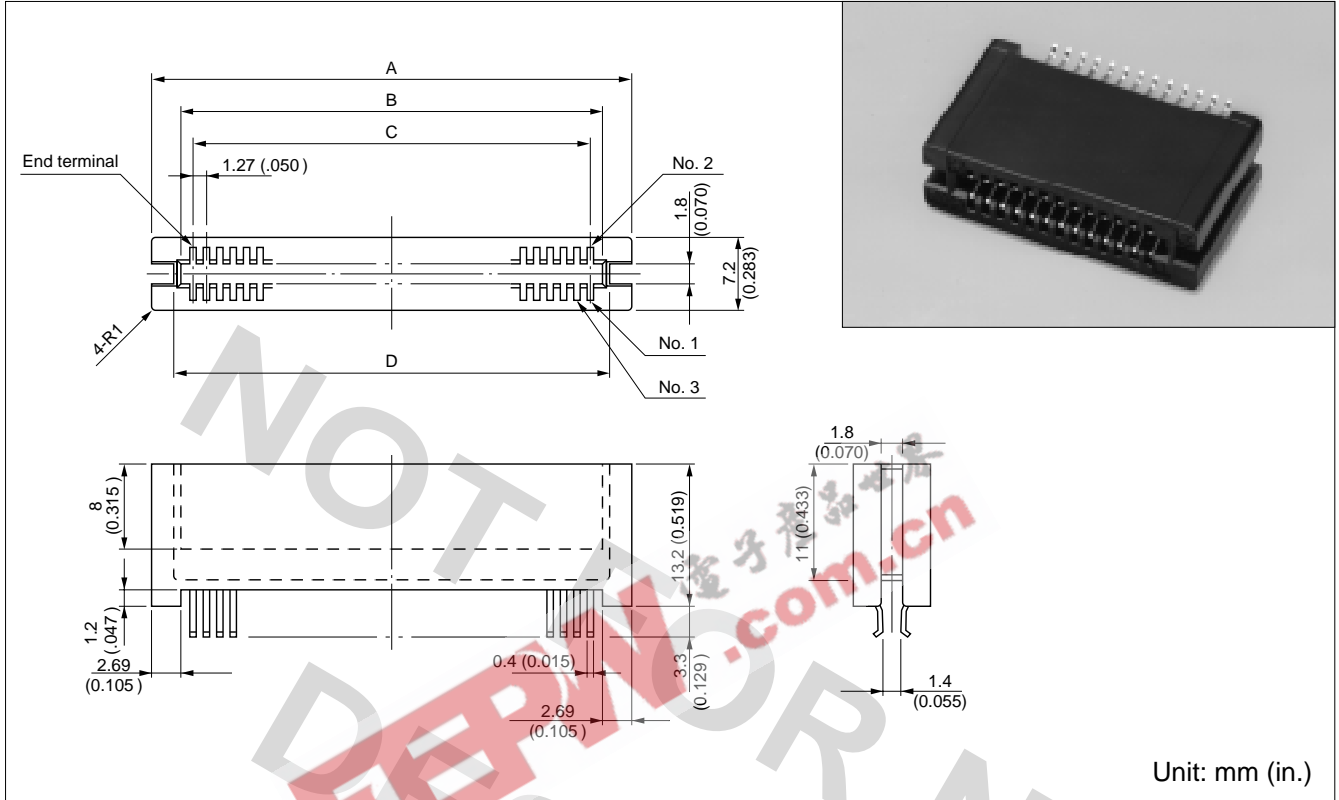

### ■ PC BOARD PATTERN

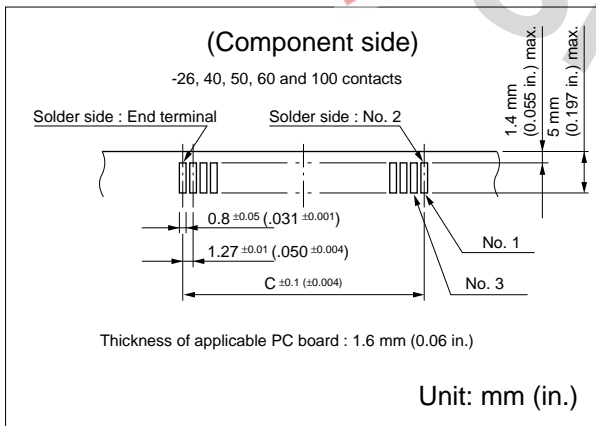

### ■ MATING PC BOARD CARD EDGE PATTERN

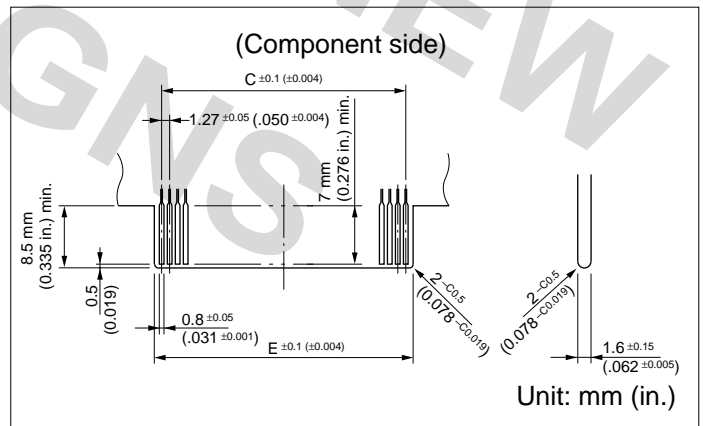

### ■ PART NUMBERS AND DIMENSIONS

Number of contacts	Part number	Dimensions: mm (in.)				
		A	B	C	D	E
26	FCN-228J026-G/0-01	23.59 (0.928)	17.78 (0.700)	15.24 (0.600)	19.71 (0.775)	17.58 (0.692)
40	FCN-228J040-G/0-01	32.48 (1.278)	26.67 (1.050)	24.13 (0.950)	28.60 (1.125)	26.47 (1.042)
50	FCN-228J050-G/0-01	38.83 (1.528)	33.02 (1.300)	30.48 (1.200)	34.95 (1.375)	32.82 (1.292)
60	FCN-228J060-G/0-01	45.18 (1.778)	39.37 (1.550)	36.83 (1.450)	41.30 (1.625)	39.17 (1.542)
100	FCN-228J100-G/0-01	70.58 (2.778)	64.77 (2.550)	62.23 (2.450)	66.70 (2.625)	64.57 (2.542)

# 228 Series (Card Edge Type)

## Fujitsu Takamisawa International Headquarter Offices

[www.fujitsu.takamisawa.com](http://www.fujitsu.takamisawa.com)

### Japan

Fujitsu Takamisawa Component Limited  
Global Marketing and Sales  
Gotanda-Chuo Building  
3-5, Higashigotanda 2-chome, Shinagawa-ku  
Tokyo 141, Japan  
Tel: (81-3) 5449-7010  
Fax: (81-3) 5449-2626

### North and South America

Fujitsu Takamisawa America, Inc.  
250 E. Caribbean Drive  
Sunnyvale, CA 94089 U.S.A.  
Tel: (1-408) 745-4900  
Fax: (1-408) 745-4970

### Europe

Fujitsu Takamisawa Europe B.V.  
Diamantlaan 25  
2132 WV Hoofddorp  
Netherlands  
Tel: (31-23) 5560910  
Fax: (31-23) 5560950

### Asia Pacific

Fujitsu Takamisawa Asia Pacific Pte. Ltd.  
102E Pasir Panjang Road  
#04-01 Citilink Warehouse Complex  
Singapore 118529  
Tel: (65) 375-8560  
Fax: (65) 273-3021

EEPW 电子产品世界  
.com.cn